



ENTERED



AUG 13 1963

2302

San Francisco Law Library

436 CITY HALL

No. 174102

EXTRACT FROM RULES

Rule 1a. Books and other legal material may be borrowed from the San Francisco Law Library for use within the City and County of San Francisco, for the periods of time and on the conditions hereinafter provided, by the judges of all courts situated within the City and County, by Municipal, State and Federal officers, and any member of the State Bar in good standing and practicing law in the City and County of San Francisco. Each book or other item so borrowed shall be returned within five days or such shorter period as the Librarian shall require for books of special character, including books constantly in use, or of unusual value. The Librarian may, in his discretion, grant such renewals and extensions of time for the return of books as he may deem proper under the particular circumstances and to the best interests of the Library and its patrons. Books shall not be borrowed or withdrawn from the Library by the general public or by law students except in unusual cases of extenuating circumstances and within the discretion of the Librarian.

Rule 2a. No book or other item shall be removed or withdrawn from the Library by anyone for any purpose without first giving written receipt in such form as shall be prescribed and furnished for the purpose, failure of which shall be ground for suspension or denial of the privilege of the Library.

Rule 5a. No book or other material in the Library shall have the leaves folded down, or be marked, dog-eared, or otherwise soiled, defaced or injured, and any person violating this provision shall be liable for a sum not exceeding treble the cost of replacement of the book or other material so treated and may be denied the further privilege of the Library.

101-3195

**In the United States Court of Appeals
for the Ninth Circuit**

NATIONAL LABOR RELATIONS BOARD, PETITIONER

v.

AL TATTI, INCORPORATED, RESPONDENT

**On Petition for Enforcement of An Order of the
National Labor Relations Board**

**BRIEF FOR THE NATIONAL LABOR RELATIONS
BOARD**

STUART ROTHMAN,
General Counsel,

DOMINICK L. MANOLI,
Associate General Counsel,

MARCEL MALLET-PREVOST,
Assistant General Counsel,

**WARREN M. DAVISON,
GLEN M. BENDIXSEN,**
Attorneys,

National Labor Relations Board.



I N D E X

| | Page |
|--|------|
| Jurisdiction | 1 |
| Statement of the case..... | 2 |
| I. The Board's findings of fact..... | 2 |
| A. The majority of respondent's service department employees join the Union and the Union requests recognition and contract negotiations | 3 |
| B. Respondent threatens and interrogates the employees concerning the Union and discharges Berg and Filbig..... | 4 |
| II. The Board's conclusions and order..... | 8 |
| Argument | 9 |
| Substantial evidence supports the Board's findings that in response to the Union's demand for recognition respondent committed unfair labor practices in an effort to dissipate the Union's majority status | 9 |
| A. The Board properly found that respondent violated Section 8 (a) (3) and (1) by discharging Berg and Filbig because of their union activity, and interrogated and threatened employees regarding union activity in violation of Section 8 (a) (1)..... | 9 |
| 1. Substantial evidence supports these findings | 9 |
| 2. The Board properly rejected respondent's explanation for the discharges..... | 12 |
| B. The Board properly found that respondent refused to bargain with the Union in violation of Section 8 (a) (5) and (1)..... | 15 |
| Conclusion | 19 |
| Appendix A..... | 20 |
| Appendix B..... | 23 |
| Appendix C..... | 24 |

II

AUTHORITIES CITED

| Cases: | Page |
|--|--------|
| <i>American Steel Foundries v. N.L.R.B.</i> , 158 F. 2d 896 (C.A. 7)..... | 14 |
| <i>Angwell Curtain Co. v. N.L.R.B.</i> , 192 F. 2d 899 (C.A. 7)..... | 10-11 |
| <i>Carpinteria Lemon Ass'n v. N.L.R.B.</i> , 240 F. 2d 554 (C.A. 9), cert. den., 354 U.S. 909..... | 11 |
| <i>Joy Silk Mills, Inc. v. N.L.R.B.</i> , 185 F. 2d 732 (C.A. D.C.), cert. den., 341 U.S. 914..... | 16, 17 |
| <i>Magnolia Petroleum Co. v. N.L.R.B.</i> , 200 F. 2d 148 (C.A. 5)..... | 14 |
| <i>N.L.R.B. v. Anderson</i> , 206 F. 2d 409 (C.A. 9), cert. den., 346 U.S. 938..... | 12 |
| <i>N.L.R.B. v. Auto Ventshade, Inc.</i> , 276 F. 2d 303 (C.A. 5)..... | 18 |
| <i>N.L.R.B. v. Brady Aviation Corp.</i> , 224 F. 2d 23 (C.A. 5)..... | 10 |
| <i>N.L.R.B. v. Dan River Mills, Inc.</i> , 274 F. 2d 381 (C.A. 5)..... | 14 |
| <i>N.L.R.B. v. Dant & Russell, Ltd.</i> , 207 F. 2d 165 (C.A. 9)..... | 12 |
| <i>N.L.R.B. v. Ferguson</i> , 257 F. 2d 88 (C.A. 5)..... | 10 |
| <i>N.L.R.B. v. Geigy Co., Inc.</i> , 211 F. 2d 553 (C.A. 9), cert. den., 348 U.S. 821..... | 16, 17 |
| <i>N.L.R.B. v. W. T. Grant Co.</i> , 199 F. 2d 711 (C.A. 9), cert. den., 344 U.S. 928..... | 16 |
| <i>N.L.R.B. v. Homedale Tractor & Equip.</i> , 211 F. 2d 309 (C.A. 9), cert. den., 348 U.S. 833..... | 10, 11 |
| <i>N.L.R.B. v. Idaho Egg Producers, Inc.</i> , 229 F. 2d 821 (C.A. 9)..... | 16 |
| <i>N.L.R.B. v. Int'l Longshoremen's & Warehousemen's Union, Local 10, et al.</i> , 283 F. 2d 558 (C.A. 9)..... | 12 |
| <i>N.L.R.B. v. Kohler Co.</i> , 220 F. 2d 3 (C.A. 7)..... | 15 |
| <i>N.L.R.B. v. Mexia Textile Mills, Inc.</i> , 339 U.S. 563 | 19 |
| <i>N.L.R.B. v. Monroe Feed Store</i> , 237 F. 2d 116 (C.A. 9)..... | 11 |
| <i>N.L.R.B. v. Osbrink</i> , 218 F. 2d 341 (C.A. 9), cert. den., 349 U.S. 928..... | 15 |
| <i>N.L.R.B. v. Parma Water Lifter Co.</i> , 211 F. 2d 258 (C.A. 9), cert. den., 348 U.S. 829..... | 16 |

III

| Cases—Continued: | Page |
|--|-----------------------|
| <i>N.L.R.B. v. Poultry Enterprises, Inc.</i> , 207 F. 2d 522 (C.A. 5)..... | 15 |
| <i>N.L.R.B. v. Robbins Tire & Rubber Co.</i> , 161 F. 2d 798 (C.A. 5)..... | 15 |
| <i>N.L.R.B. v. Scott & Scott</i> , 245 F. 2d 926 (C.A. 9) | 16 |
| <i>N.L.R.B. v. Sebastopol Apple Growers Union</i> , 269 F. 2d 705 (C.A. 9)..... | 11 |
| <i>N.L.R.B. v. Southern Desk Co.</i> , 246 F. 2d 53 (C.A. 4)..... | 10 |
| <i>N.L.R.B. v. State Center Warehouse</i> , 193 F. 2d 156 (C.A. 9)..... | 12, 14 |
| <i>N.L.R.B. v. Sun Co. of San Bernadino</i> , 215 F. 2d 379 (C.A. 9)..... | 10, 11 |
| <i>N.L.R.B. v. Texas Independent Oil Co., Inc.</i> , 232 F. 2d 447 (C.A. 9)..... | 10 |
| <i>N.L.R.B. v. Trimfit of California</i> , 211 F. 2d 206 (C.A. 9)..... | 15, 15-16, 17, 18, 19 |
| <i>N.L.R.B. v. Walton Mfg. Co.</i> , 369 U.S. 404..... | 12 |
| <i>N.L.R.B. v. Whitelight Products Div.</i> , 298 F. 2d 12 (C.A. 1), cert. den., 369 U.S. 887..... | 18 |

Statute:

| | |
|--|----------|
| National Labor Relations Act, as amended (61 Stat. 136, 73 Stat. 519, 29 U.S.C., Sec. 151, <i>et seq.</i>)..... | 1 |
| Section 8 (a) (1)..... | 2, 9, 15 |
| Section 8 (a) (3)..... | 2, 9 |
| Section 8 (a) (5)..... | 2, 15 |
| Section 10 (e)..... | 1 |



**In the United States Court of Appeals
for the Ninth Circuit**

No. 18136

NATIONAL LABOR RELATIONS BOARD, PETITIONER

v.

AL TATTI, INCORPORATED, RESPONDENT

**On Petition for Enforcement of An Order of the
National Labor Relations Board**

**BRIEF FOR THE NATIONAL LABOR RELATIONS
BOARD**

JURISDICTION

This case is before the Court upon petition of the Board, pursuant to Section 10(e) of the National Labor Relations Act, as amended (61 Stat. 136, 73 Stat. 519, 29 U.S.C., Sec. 151, *et seq.*),¹ for enforcement of its order issued against respondent on March 9, 1962. The Board's decision and order (R.

¹ The pertinent statutory provisions are reprinted as Appendix A *infra*, pp. 20-22.

14-A-28)² are reported at 136 NLRB No. 17. This Court has jurisdiction, the unfair labor practices having occurred in Downey, California, within this judicial circuit.³

STATEMENT OF THE CASE

I. The Board's findings of fact

Briefly, the Board found that respondent violated Section 8(a)(1) of the Act by threatening its employees and interrogating them regarding their union activities. The Board further found that respondent violated Section 8(a)(3) and (1) by discharging employees George Filbig and Werner Berg because of their union activity. Finally, the Board found that respondent violated Section 8(a)(5) and (1) by refusing to recognize and bargain with the Union.⁴ The facts underlying the Board's findings are summarized below.

² References to the pleadings, the decision and order of the Board, and other papers, reproduced as "Volume I, Pleadings," are designated "R." References to portions of the stenographic transcript reproduced pursuant to Court Rules 10 and 17 are designated "Tr." "G.C. Ex." refers to exhibits of the General Counsel. Wherever in a series of references a semicolon appears, the references preceding the semicolon are to the Board's findings; those following are to the supporting evidence.

³ Respondent sells and services Volkswagen automobiles. It makes substantial sales and shipments in interstate commerce and no jurisdictional issue is involved. (R. 4-5, 10, 14-A.)

⁴ International Association of Machinists, AFL-CIO.

A. A majority of respondent's service department employees join the Union and the Union requests recognition and contract negotiations

During the events involved here, respondent's service department consisted of a maximum of 11 employees who, for the most part, are mechanics with special technical experience and training for work on Volkswagen automobiles. It is not disputed that the department is an appropriate unit for collective bargaining and that, as set forth below, a majority of the employees designated the Union as their bargaining agent. (R. 17-18 n. 3, 25; Tr. 10-11, 238, 331-332.)

In the early spring of 1961, mechanics Werner Berg and George Filbig spoke to other employees about joining a union.⁵ In April, Berg and Filbig met with Charles Edwards, a Union representative. They told Edwards they wanted to become organized because of "working conditions" maintained by respondent. Edwards gave them Union authorization cards and literature. (R. 15, 25; Tr. 91-94, 110, 151-152, 191-192.) A month or so later, the Union held a meeting of the employees and seven of them signed cards (R. 15, 25; Tr. 42-47, 95-96, 131, 135-136, 152-156, 192, GC Ex. 5-A to 5-G).

On June 19, the Union sent respondent a letter stating that it represented a majority of the service

⁵ Shortly before, in January, Berg had asked Louis Meeks, then respondent's service manager and admittedly a supervisor under the Act, why respondent paid its mechanics on a commission basis. Meeks replied that it was "to keep up the wage standards, and to keep the union out." (R. 2, n. 1; Tr. 13-14, 157, 160.)

department employees, and requesting recognition and a bargaining meeting (R. 15, 25-26; 7, 15-16, 303, G.C. Ex. 2). Al Tatti, respondent's president and principal owner, was then traveling abroad. Office Manager Clarence McCall, whom Tatti had left in charge of the business, gave the letter to a labor-relations consultant. However, a reply was never sent, and respondent did not contact the Union, even after Tatti returned a few weeks later. (R. 15, 19 n. 4, 25-26; Tr. 16, 19-20, 126, 128, 185-186, 239-240, 267, 269-272, 280, 303, 304-305, 310.) Two days after the Union sent the letter, it filed a representation petition seeking a Board election (R. 15, 2; Tr. 8-9, 16, 303).

B. Respondent threatens and interrogates the employees concerning the Union and discharges Berg and Filbig

About a week later, on June 30, Sales Manager Albert Lauer, admittedly a supervisor under the Act, asked Berg "why [the employees] were joining the union," and told Berg that the Union would not do them any good (R. 16, 26; Tr. 14, 160-162). About two weeks later, Berg walked by Lauer and employee Eddie Taylor at about 4:30 in the afternoon; 30 minutes before quitting time. Lauer motioned to Berg, and told him, "Mr. Tatti was going to get real tough on anybody that was drinking beer," so he "should watch" himself.⁶ Berg replied that he was

⁶ Taylor, who appeared as respondent's witness at the hearing, testified that Lauer stated to him and Berg, "No drinking tonight, boys" (R. 18; Tr. 293).

not worried because he never drank "during working hours." (R. 18; Tr. 163.) (As set forth *infra*, pp. 12-15, for at least 2 years the employees in the shop have often drunk a beer on the premises after quitting time at 5 p.m.). About 5:30 p.m., Taylor asked Berg, Filbig, and employee Max Spitznagel, who were cleaning up to go home, if they wanted a can of beer. They all did, and Taylor went to a nearby liquor store and brought back four cans. (R. 18; Tr. 68, 69, 82, 83, 89, 97, 164, 165, 290, 294.) Taylor drank a small part of his, then hurriedly left (R. 18; Tr. 98, 116, 118, 166, 199-200). Right after Taylor left, Tatti and Sales Manager Lauer appeared in the shop.⁷ Tatti walked over to Berg, who already had the upper part of his work clothes off, grabbed the beer from his hands, and told him he was first fired for drinking on the job. When Berg stated that it was "past working time," and he "wasn't drinking on the job," Tatti replied that he was fired for "drinking on the premises." (R. 18; Tr. 69, 84-85, 98, 119, 168, 338, 342.) Tatti then asked Filbig if he had drunk any beer. Filbig admitted that he had, and Tatti fired him also. (R. 18; Tr. 68-69, 100, 337.) Berg then observed that Spitznagel had also drunk a beer. Tatti stated he "didn't see" him do it, and walked out of the shop (R. 18, 27 n. 2; Tr. 100, 170). Respondent has work rules posted governing

⁷ Tatti testified that he came back in the shop just then to help Lauer check a car serial number against an entry in the service book record (R. 17; Tr. 83, 98, 229, 283, 327, 342).

employee conduct, but has no rule posted dealing with drinking (R. 18, 27 n. 2; Tr. 261-262).

Three days later, on July 21, the Union, having learned of the employees' discharges, withdrew its election petition and filed the instant unfair labor practice charges (R. 15, 27; Tr. 9-10, 21).

Berg and Filbig were discharged on July 18, a Tuesday. On the following Saturday, Sales Manager Lauer called them to say that respondent wanted them back, and asked them to report to Tatti on Monday morning. (R. 15, n. 1, 27; Tr. 101, 103, 171.) When they reported on Monday, Tatti told them they could return to work if they signed a statement that they were fired for drinking on the job and did not expect backpay. Both men indicated that they wanted to come back, but neither would agree to sign such a statement and both said they wanted to talk to the Union about the matter. (R. 15-16, 26; Tr. 104-106, 173.) Later that day Tatti sent them a telegram reading, "New developments see me today about job" (R. 16, Tr. 106, 174, 238, G.C. Ex. 6). Berg and Filbig went to see Tatti late that afternoon. He told them they could go back to work with "no stipulation this time" (R. 16, 26; Tr. 106-107, 176). They returned to work the next morning, July 25 (R. 16; Tr. 100, 176). The next day, July 26, as employee Leroy Vander Stroom and Tatti were driving to another automobile agency, Tatti asked him who got the Union "started in the shop." And, as they pulled up to the agency, Tatti, referring to the other agency, commented that "these boys finally realized that this

union didn't work out for them." (R. 16; Tr. 24-25, 28-29, 33-36, 249-250.)

A few days later, on July 31, mechanic Milton Tubbs returned from vacation. He remarked to Louis Meeks, then respondent's service manager (see *supra*, p. 3, n. 5), that he had "heard that [Berg and Filbig] got fired or something." Meeks said it was true, "they were organizing—trying to organize a union." (R. 16, 26; Tr. 14, 131-133.) Two weeks later, on August 16, Tatti told employee Willem Vander Stroom that "the mechanics could be replaced if the Union came in" (R. 16; Tr. 137). On another occasion Tatti asked Vander Stroom "how many people the Union had." Vander Stroom avoided answering, and Tatti, counting on his fingers, surmised that "it came out about even," and that "as long as we can keep it that way they can't win." (R. 16; Tr. 139.) A few weeks later, in late September, Vander Stroom asked Perk Ogden, the new service manager and admittedly a supervisor, if "Tatti had accepted the fact that the union was going to come in." Ogden replied that the Union would "never get in" because "we could replace the mechanics." Ogden indicated he "knew where [respondent] could get them." (R. 16; Tr. 14, 141, 286.)⁸

⁸ Page 141 of the transcript of testimony was inadvertently omitted from the photostatic copy of the transcript and is set forth *infra*, p. 24, as Appendix C.

II. The Board's conclusions and order

The Board agreed with the Trial Examiner that respondent violated Section 8(a)(1),(3) and (5) of the Act. Thus, the Board found that the inquiries and statements by respondent's officials constituted, under the circumstances, coercive interrogation and threats of reprisals, in violation of Section 8(a)(1) (R. 26). The Board further found that respondent discharged employees Werner Berg and George Filbig because of their union activity and active participation in the Union's campaign, in violation of Section 8(a)(3) and (1), rejecting as pretextuous respondent's contention that the employees were discharged for drinking beer on the premises. (R. 27). Finally, the Board held that respondent violated Section 8(a)(5) and (1) by failing to answer the Union's request for recognition and bargaining, and immediately setting out to undermine the Union's majority through unfair labor practices (R. 27).

The Board's order requires respondent to cease and desist from the unfair labor practices found and from in any other manner impinging on employee rights guaranteed under the Act. Affirmatively, the order requires respondent to bargain with the Union upon request; to compensate employees Berg and Filbig for loss of wages; and to post appropriate notices. (R. 20-23, 28.)

ARGUMENT

SUBSTANTIAL EVIDENCE SUPPORTS THE BOARD'S FINDINGS THAT IN RESPONSE TO THE UNION'S DEMAND FOR RECOGNITION RESPONDENT COMMITTED UNFAIR LABOR PRACTICES IN AN EFFORT TO DISSIPATE THE UNION'S MAJORITY STATUS

- A. The Board properly found that respondent violated Section 8(a)(3) and (1) by discharging Berg and Filbig because of their union activity, and interrogated and threatened employees regarding union activity in violation of Section 8(a)(1)

1. *Substantial evidence supports these findings*

As shown in the Statement, in January 1961, mechanic Werner Berg, apparently dissatisfied with working conditions, asked Service Manager Louis Meeks why respondent paid its mechanics on a commission basis. Meeks replied it was to "keep the union out." Subsequently, Berg and fellow mechanic George Filbig took the initiative in contacting the Union, and successfully recruited a majority of the employees. However, when the Union requested recognition as their bargaining agent, respondent ignored the request. Instead, it set out to determine, by asking Berg, "why [the employees] were joining the union" (*supra*, p. 4). Then, having ignored the Union's request for a month, respondent abruptly discharged Berg and Filbig. Respondent clearly knew, as the Board found (R. 27), that these two employees "were the instigators of the Union's campaign." Thus, as indicated above, Sales Manager Lauer sought out Berg before the discharges to discover why the employees were turn-

ing to the Union. A week after the discharges and after the Union had filed unfair labor practice charges, respondent, while eventually reinstating the two men, first solicited their signed statements that union activity had not motivated their discharges. Such action strongly suggests that respondent knew it had deprived them of employment for proscribed reasons and was attempting to avoid their seeking relief in the remedial provisions of the Act. Cf. *N.L.R.B. v. Homedale Tractor & Equip. Co.*, 211 F. 2d 309, 314 (C.A. 9), cert. den., 348 U.S. 833; *N.L.R.B. v. Brady Aviation Corporation*, 224 F. 2d 23, 25 (C.A. 5). In any event, the record establishes that union activity motivated the discharges. Just a few days after the men were reinstated, Service Manager Meeks indicated (*supra*, p. 7) that they had been discharged for "trying to organize a union." This statement by a highly placed company official, "who is in a position to know the reason for the discharge," eliminates all doubt as to motive. *N.L.R.B. v. Sun Co. of San Bernadino*, 215 F. 2d 379, 381 (C.A. 9).⁹

Moreover, following the discharges respondent interrogated and threatened employees in a manner clearly violative of Section 8(a)(1) and revealed, as to the discharges, "what its attitude undoubtedly was immediately preceding that event" (*Angwell*

⁹ Accord, *N.L.R.B. v. Texas Independent Oil Co.*, 232 F. 2d 447, 451 (C.A. 9); *N.L.R.B. v. Ferguson*, 257 F. 2d 88, 90 (C.A. 5); *N.L.R.B. v. Southern Desk Co.*, 246 F. 2d 53, 54 (C.A. 4).

Curtain Company, Inc. v. N.L.R.B., 192 F. 2d 899, 903 (C.A. 7)). Cf. *N.L.R.B. v. Homedale Tractor & Equipment Co.*, 211 F. 2d 309, 313, 314-316 (C.A. 9), cert. den., 348 U.S. 833. As shown in the Statement, through various supervisory officials, respondent questioned employees about the Union, coupling the inquiries with intimations that the advent of the Union would affect job security. To a large extent, the employees were approached *after* Berg and Filbig had been abruptly discharged for union activity. As respondent had dramatically demonstrated its antiunion hostility by firing the two men most active in bringing the Union in, it was well aware that its inquiries about the Union could easily have an intimidating effect on the employees. Moreover, President Tatti, as well as Service Manager Perk Ogden, accompanied union inquiries with remarks that the Union would "never get in" because respondent "could replace the mechanics." That such conducted tainted the interrogations with coercion and constituted threats of reprisals, in violation of Section 8(a)(1), is too well settled to require discussion.¹⁰ In sum, while the Board's finding of discriminatory motive is amply supported by direct evidence, that finding is underscored by the union hostility established by respondent's interference with its employees' Section 7 rights

¹⁰ *N.L.R.B. v. Sebastopol Apple Growers Union*, 269 F. 2d 705, 707-708 (C.A. 9); *Carpinteria Lemon Assn. v. N.L.R.B.*, 240 F. 2d 554, 558 (C.A. 9), certiorari denied, 354 U.S. 909; *N.L.R.B. v. Monroe Feed Store*, 237 F. 2d 116 (C.A. 9), enforcing 110 NLRB 630; *N.L.R.B. v. Sun Co. of San Bernardino*, 215 F. 2d 379, 381 (C.A. 9).

and by its unlawful refusal to accept their chosen union as their bargaining representative (see discussion *infra*, pp. 15-18).

The testimony of respondent's officials that several of the unlawful statements were not made as testified to by the General Counsel's witnesses, raises merely a question of credibility. The Trial Examiner, noting "several instances of implausibility or conflict" in testimony by respondent's representatives, largely credited the General Counsel's witnesses (R. 16, n. 2). The Board affirmed his findings. "For obvious reasons, questions of credibility were for the Examiner." *N.L.R.B. v. State Center Warehouse*, 193 F. 2d 156, 157 (C.A. 9). See also *N.L.R.B. v. Walton Mfg. Co.*, 369 U.S. 404, 407-408; *N.L.R.B. v. Int'l Longshoremen's Warehousemen's Union, Local 10, et al.*, 283 F. 2d 558, 562-563 (C.A. 9); *N.L.R.B. v. Anderson*, 206 F. 2d 409 (C.A. 9), cert. den., 346 U.S. 938.

2. The Board properly rejected respondent's explanation for the discharges

The Board's finding of discriminatory motive is "strengthened by the fact that the explanation for the discharge[s] offered by respondent fails to stand under scrutiny." *N.L.R.B. v. Dant & Russell*, 207 F. 2d 165, 167 (C.A. 9). Thus, respondent contended that Berg and Filbig, concededly valuable, "technically well experienced," and "school[ed]" mechanics (R. 18; Tr. 238), were discharged for drink-

ing beer on the premises after working hours.¹¹ However, the record is replete with evidence that the employees in the service department regularly have a "can of beer" after quitting work and while "cleaning up" to go home. The several employees called to testify uniformly stated that for at least the last two years, "a beer" after quitting time, in the presence of various supervisory personnel, was "almost" a "weekly" occurrence, and, indeed, had taken place just a week before the discharges. (R. 17, 27 n. 2; Tr. 58-67, 73-82, 88-89, 107-109, 127-128, 176-180, 182, 194.) Consistent with this testimony, respondent had posted work rules aimed at employee conduct on the premises, but none of these rules dealt with drinking beer (R. 18; Tr. 70-71, 261-262). Indeed, as the Trial Examiner observed (R. 17), "the record is barren that drinking beer after working hours had ever been considered an infraction of a rule * * *."¹² Significantly, in June 1961, a month before the discharges, Sales Manager Lauer in return for a favor performed by one of the employees, gave this employee \$1.50

¹¹ Respondent's contention that the men were still working does not merit extended discussion, as respondent conceded that the events occurred after quitting time, 5 p.m. Moreover, its contention that Filbig and Berg were discharged for cause rests solely on the *discredited* testimony of Tatti and Sales Manager Lauer.

¹² Tatti's testimony that he personally interviewed applicants and told them drinking was not allowed on the premises was flatly contradicted by the employee witnesses, and was discredited (R. 17; Tr. 72, 86, 124, 203-204, 228, 263-264, 336, 341, 346-347, 354-355).

to buy a 6-pack carton of beer for employees who had stayed at work late the previous day to put seats in a car. The beer was drunk on the premises after working hours. (R. 17; Tr. 66, 87-88, 180-181, 208-209, 312, 318).¹³

Plainly, if respondent had a rule against drinking on its premises after the shop was closed, "no such policy had ever been revealed to anyone before."¹⁴ *American Steel Foundries v. N.L.R.B.*, 158 F. 2d 896, 899 (C.A. 7). Cf. *N.L.R.B. v. State Center Warehouse, etc.*, 193 F. 2d 156, 158 (C.A. 9). Respondent's sudden assertion of such a policy on the advent of a union campaign which, as we have shown, it opposed and sought to defeat by unlawful means, warrants the Board's finding that it is but a "patent pretext for [the] discharges" (R. 27). Cf. *State Center Warehouse, etc., supra*.¹⁵ Furthermore, Tatti's refusal to take *any* disciplinary action against mechanic Max Spitznagel, who he knew had been drinking beer with Berg and Filbig, supports this finding. As far as the record reveals, the only dis-

¹³ Lauer's testimony that he gave the \$1.50 as a "tip" was discredited (R. 17).

¹⁴ Filbig did testify that about 3 years before Tatti told him he did not "allow drinking at working hours * * * because it would make a bad face to the customers" (R. 17; Tr. 336). Obviously, this is not inconsistent with a willingness to allow the drinking of beer by the mechanics *after* working hours.

¹⁵ See, in addition, *Magnolia Petroleum Co. v. N.L.R.B.*, 200 F. 2d 148, 149 (C.A. 5); *N.L.R.B. v. Dan River Mills*, 274 F. 2d 381, 384 (C.A. 5).

tinguishing factor between the discriminatees and Spitznagel is their active part in the Union's campaign.¹⁶ See, e.g., *N.L.R.B. v. Osbrink*, 218 F. 2d 341, 343 (C.A. 9), cert. den., 349 U.S. 928; *N.L.R.B. v. Robbins Tire & Rubber Co.*, 161 F. 2d 798, 801 (C.A. 5); *N.L.R.B. v. Kohler Co.*, 220 F. 2d 3, 9 (C.A. 7).

B. The Board properly found that respondent refused to bargain with the Union in violation of Section 8(a)(5) and (1)

As indicated, *supra*, p. 3, it is not disputed that the Union represented a majority of the employees in a proper unit at the time that it requested recognition and a bargaining meeting. Furthermore, respondent at no time challenged the Union's majority. Its sole defense before the Board for its refusal to recognize the employees' chosen bargaining representative was that the filing of the election petition relieved it of its duty to recognize the Union until its majority was established in a Board election.

Respondent's defense in this regard is wholly without merit. It is settled law that the Union's filing of the representation petition did not relieve respondent of its bargaining obligation. *N.L.R.B. v. Trimfit of California, Inc.*, 211 F. 2d 206, 209, n. 1 (C.A. 9); *N.L.R.B. v. Poultry Enterprises, Inc.*, 207 F. 2d 522, 524-525 (C.A. 5). In *N.L.R.B. v. Trimfit of Cal-*

¹⁶ It is equally significant that as far as the record reveals, Spitznagel, concededly in the bargaining unit, did not join the Union (R. 18, 25; Tr. 11, 331-332, G.C. Ex. 5-A to 5-G). And, as shown *supra*, p. 7, Tatti revealed he had some knowledge of who had joined by "counting them on his fingers" before employee Willem Vander Stroom.

fornia, Inc., supra at 209, this Court stated the familiar and well-established rule here applicable:

Respondent contends that it had no duty to bargain until the union had established its majority status by a Board election. There is no absolute right vested in an employer to demand an election. * * * If an employer in good faith doubts the union's majority, he may, without violating the Act, refuse to recognize the union until the claim is established by a Board election. A doubt professed by an employer as to the union's majority claim must be genuine. Otherwise the employer has a duty to bargain and may not insist upon an election.

Accord, *N.L.R.B. v. Idaho Egg Producers*, 229 F. 2d 821 (C.A. 9); *N.L.R.B. v. W. T. Grant Co.*, 199 F. 2d 711, 712 (C.A. 9), cert. den., 344 U.S. 928; *N.L.R.B. v. Parma Water Lifter Co.*, 211 F. 2d 258, 263 (C.A. 9), cert. den., 348 U.S. 829; *N.L.R.B. v. Geigy*, 211 F. 2d 553, 556 (C.A. 9), cert. den., 348 U.S. 821; *N.L.R.B. v. Scott & Scott*, 245 F. 2d 926, 928 (C.A. 9); *Joy Silk Mills v. N.L.R.B.*, 185 F. 2d 732, 741 (C.A.D.C.), cert. den., 341 U.S. 914.

Manifestly, this rule applies with even greater force where, as here, respondent does not even profess "doubts" of any kind as to the Union's majority. We submit, in short, that the instant case is a classic example of an employer whose refusal to honor a Union's claim for recognition based on a card majority was solely for the purpose of gaining time "to

dissipate the union's majority * * *." ¹⁷ *Trimfit of California, supra*, 211 F. 2d at 210. See also, cases cited, *supra*, p. 16. Thus respondent ignored the Union's demand and embarked on a program of interrogations, threats, and discriminatory discharges of the two most active union adherents.¹⁸ The design of these actions is patently reflected in Tatti's statement to an employee that as long as he could keep the number of the people in the Union about "even," it could not "win" (*supra*, p. 7). However, respondent, not having a good faith doubt of the Union's majority, had a duty to recognize and bargain with it. It cannot, as Tatti sought, use the "election provisions [of the Act] as a procedural device * * * [to] secure time necessary to defeat efforts toward organization being made by a union * * *." *Joy Silk Mills v. N.L.R.B.*, 185 F. 2d 732, 741 (C.A.D.C.), cert. den., 341 U.S. 914.

Finally, respondent's contention that the Union's *withdrawal* of the election petition is inconsistent with a claim of majority is similarly without merit. Respondent's conduct, particularly the discriminatory

¹⁷ It is, of course, well settled that "a union may be effectively designated as the bargaining representative by the signing of authorization cards [citing cases]." *N.L.R.B. v. Geigy Company, Inc.*, 211 F. 2d 553, 556 (C.A. 9), cert. den., 348 U.S. 821. And, as in the instant case, "There was no necessity for the union to offer proof of the genuineness of its majority claim absent a challenge by respondent." *Trimfit of California, supra*, 211 F. 2d at 210.

¹⁸ Significantly, we submit, the discharge of two employees was just sufficient to destroy the Union's 7 out of 11 majority.

discharges, had destroyed the possibility of free choice by the employees. The Union's only recourse was to forego the election, establish its demonstrated majority in an unfair labor practice proceeding, and secure a bargaining order.¹⁹ Accordingly, its "withdrawal of the representation petition in no way prejudiced [its] demand for recognition." (*Trimfit of California, supra*, 211 F. 2d at 209 n. 1). See also, *N.L.R.B. v. Parma Water Lifter Co.*, 211 F. 2d 258, 264 (C.A. 9), cert. den., 348 U.S. 829. In sum, respondent "is hardly in a position to complain about the union's [withdrawal of its election petition] when respondent's own unfair labor practices rendered a free election impossible" (*Trimfit of California, supra*, 211 F. 2d at 210). Accord, *N.L.R.B. v. White-light Products Division*, 298 F. 2d 12, 14 (C.A. 1), cert. den., 369 U.S. 887, and cases there cited.

¹⁹ The Union's action was consistent with the Board's "settled policy not to conduct representation elections during the pendency of unfair labor practice charges." *Trimfit of California, supra*, 211 F. 2d at 206 n. 2. See also, *N.L.R.B. v. Auto Ventshade, Inc.*, 276 F. 2d 303, 307-308 (C.A. 5).

CONCLUSION

For the reasons stated, it is respectfully requested that a decree issue enforcing the Board's order in full.²⁰

STUART ROTHMAN,
General Counsel,

DOMINICK L. MANOLI,
Associate General Counsel,

MARCEL MALLET-PREVOST,
Assistant General Counsel,

WARREN M. DAVISON,
GLEN M. BENDIXSEN,
Attorneys,

National Labor Relations Board.

December 1962.

CERTIFICATE

The undersigned certifies that he has examined the provisions of Rules 18 and 19 of this court, and in his opinion the tendered brief conforms to all requirements.

MARCEL MALLET-PREVOST
Assistant General Counsel
National Labor Relations Board

²⁰ Respondent's asserted compliance with the Board's order in no way renders enforcement proceedings moot, as the Board is entitled to a decree to insure against the resumption of unfair labor practices. *N.L.R.B. v. Mexia Textile Mills, Inc.*, 339 U.S. 563, 567-568; *N.L.R.B. v. Trimfit of California, Inc.*, 211 F. 2d 206, 208 (C.A. 9).

APPENDIX A

The relevant provisions of the National Labor Relations Act, as amended (61 Stat. 136, 73 Stat. 519, 29 U.S.C., Secs. 151, *et seq.*) are as follows:

RIGHTS OF EMPLOYEES

Sec. 7. Employees shall have the right to self-organization, to form, join, or assist labor organizations, to bargain collectively through representatives of their own choosing, and to engage in other concerted activities for the purpose of collective bargaining or other mutual aid or protection, and shall also have the right to refrain from any or all of such activities except to the extent that such right may be affected by an agreement requiring membership in a labor organization as a condition of employment as authorized in section 8 (a) (3).

UNFAIR LABOR PRACTICES

Sec. 8.(a) It shall be an unfair labor practice for an employer—

(1) to interfere with, restrain, or coerce employees in the exercise of the rights guaranteed in section 7;

* * * *

(3) by discrimination in regard to hire or tenure of employment or any term or condition of employment to encourage or discourage membership in any labor organization . . .

* * * *

(5) to refuse to bargain collectively with the representatives of his employees, subject to the provisions of section 9(a).

* * * *

PREVENTION OF UNFAIR LABOR PRACTICES

Sec. 10 (a) The Board is empowered, as hereinafter provided, to prevent any person from engaging in any unfair labor practice (listed in section 8) affecting commerce. This power shall not be affected by any other means of adjustment or prevention that has been or may be established by agreement, law, or otherwise: * * *

* * * *

(e) The Board shall have power to petition any court of appeals of the United States, . . . within any circuit . . . wherein the unfair labor practice in question occurred or wherein such person resides or transacts business, for the enforcement of such order and for appropriate temporary relief or restraining order, and shall file in the court the record in the proceedings, as provided in section 2112 of title 28, United States Code. Upon the filing of such petition, the court shall cause notice thereof to be served upon such person, and thereupon shall have jurisdiction of the proceeding and of the question determined therein, and shall have power to grant such temporary relief or restraining order as it deems just and proper, and to make and enter a decree enforcing, modifying, and enforcing as so modified, or setting aside in whole or in part the order of the Board. No objection that has not been urged before the Board, its member, agent, or agency, shall be considered by the court, unless the failure or neglect to urge such objection shall be excused because of extraordinary circumstances. The findings of the Board with respect to questions of fact if supported by substantial evidence on the record considered as a whole shall be conclusive. If either party shall apply to the court for leave to adduce additional evidence and shall show to the satis-

faction of the court that such additional evidence is material and that there were reasonable grounds for the failure to adduce such evidence in the hearing before the Board, its member, agent, or agency, the court may order such additional evidence to be taken before the Board, its member, agent, or agency, and to be made a part of the record . . . Upon the filing of the record with it, the jurisdiction of the court shall be exclusive and its judgment and decree shall be final, except that the same shall be subject to review by the . . . Supreme Court of the United States upon writ of certiorari or certification as provided in section 1254 of title 28.

APPENDIX B

Pursuant to Rule 18(f) of the Rules of the Court

GENERAL COUNSEL'S EXHIBITS

| <u>No.</u> | <u>Identified</u> | <u>Offered</u> | <u>Rec'd in Evidence</u> |
|------------|-------------------|----------------|------------------------------|
| 1(c) | 4 | 3 | 4 |
| 1(f) | 4 | 3 | 4 |
| 2 | 7 | 7 | 8 |
| 5A-5G | 45 | 45 | 46 |
| 6 | 174 | 175 | 175 |

APPENDIX C

The following page of the stenographic transcript of Willem C. Vander Stroom's testimony was inadvertently omitted from the photostatic copy of the transcript and is reprinted herein:

[Tr. 141] Q. Where did it take place exactly?

A. In the service manager's office, or in the write-up office.

Q. What was said by whom?

A. Well, I asked Mr. Ogden if Mr. Tatti had accepted the fact that the union was going to come in, and he said, "No, they will never get in." I said, "How could he prevent it?" "Well," he says, "we could replace the mechanics." I asked him if he could—it just didn't seem feasible, so I asked him how he could do about getting capable replacements, you know, just to replace all six mechanics at one time, and he says he knew where they could get them.

Q. Is that all you recall about the conversation?

A. Yes.

MR. EVANS: No more questions.

CROSS EXAMINATION

Q. [By Mr. Fredricks] You say that Mr. Ogden said that the mechanics could be replaced?

A. Yes.

Q. Is that your testimony?

A. Yes.

Q. Have any mechanics been replaced in fact?

A. No.

Q. You said you had this conversation on the 23rd of September, 1961, in the p.m.?

*See also
Vol. 3190*

No. 18,139 ✓

**United States Court of Appeals
For the Ninth Circuit**

UNITED STATES OF AMERICA,
Libelant-Appellant,
vs.
1200 CANDY BARS, MORE OR LESS,
LABELED IN PART "STA-TRIM,"
Defendant-Respondent,
and
STA-TRIM CONFECTIONS, INC.,
Claimant-Appellee.

Appeal from the United States District Court,
Northern District of California, Southern Division.
Honorable William T. Sweigert, Presiding.

APPELLANT'S REPLY BRIEF

CECIL F. POOLE,
United States Attorney,
ROBERT N. ENSIGN,
Assistant United States Attorney,
442 Post Office Building,
Seventh and Mission Streets,
San Francisco, Calif.,

Attorneys for Appellant

ARTHUR A. DICKERMAN,
Attorney, Department of Health,
Education and Welfare,
1521 West Pico Boulevard,
Los Angeles 15, Calif.

Of Counsel.

FILED

DEC - 3 1962

FRANK H. SCHMID, CLERK

SUBJECT INDEX

| | <i>Page</i> |
|---|-------------|
| 1. Contrary to Appellee's Implication, the Government's Position Here Is Consistent With the Administrative Interpretation of Section 342(d) Maintained by the Food and Drug Administration Since the Enactment of That Section | 2 |
| 2. The Government Does Not Disavow the Testimony of Mr. Campbell | 5 |
| 3. The Government's Interpretation of Section 342(d) Is Not in Conflict With Section 343(j) | 6 |
| 4. Sta-Trim Candy Bars Are Not Low Calorie Products | 9 |
| 5. Appellee's References to the Question of an Interlocutory Appeal Are Confusing | 10 |

TABLE OF AUTHORITIES CITED

| | <i>Page</i> |
|--|-------------|
| Carolene Products Co. v. U. S., 140 F.2d 61, 65 (C.A. 4, 1944), affirmed 323 U.S. 18 (1944) | 8 |
| CCH Food, Drug, Cosmetic Law Reporter, page 3198, paragraph 3036 | 4 |
| Certificate | 12 |
| Federal Security Administrator v. Quaker Oats Co., 318 U.S. 218 (1943) | 8 |
| Kleinfeld and Dunn, Federal Food, Drug, and Cosmetic Act 1938-1949, pages 662-3 (CCH 1949) | 3 |
| The Merck Index (Seventh Edition, 1960), pages 976-7 | 3 |
| Section 342(d), Food and Drug Administration | 2 |
| Section 343(j), Food and Drug Administration | 6 |
| U. S. v. 62 Cases of Jam, 340 U.S. 592 (1951) | 7, 8 |

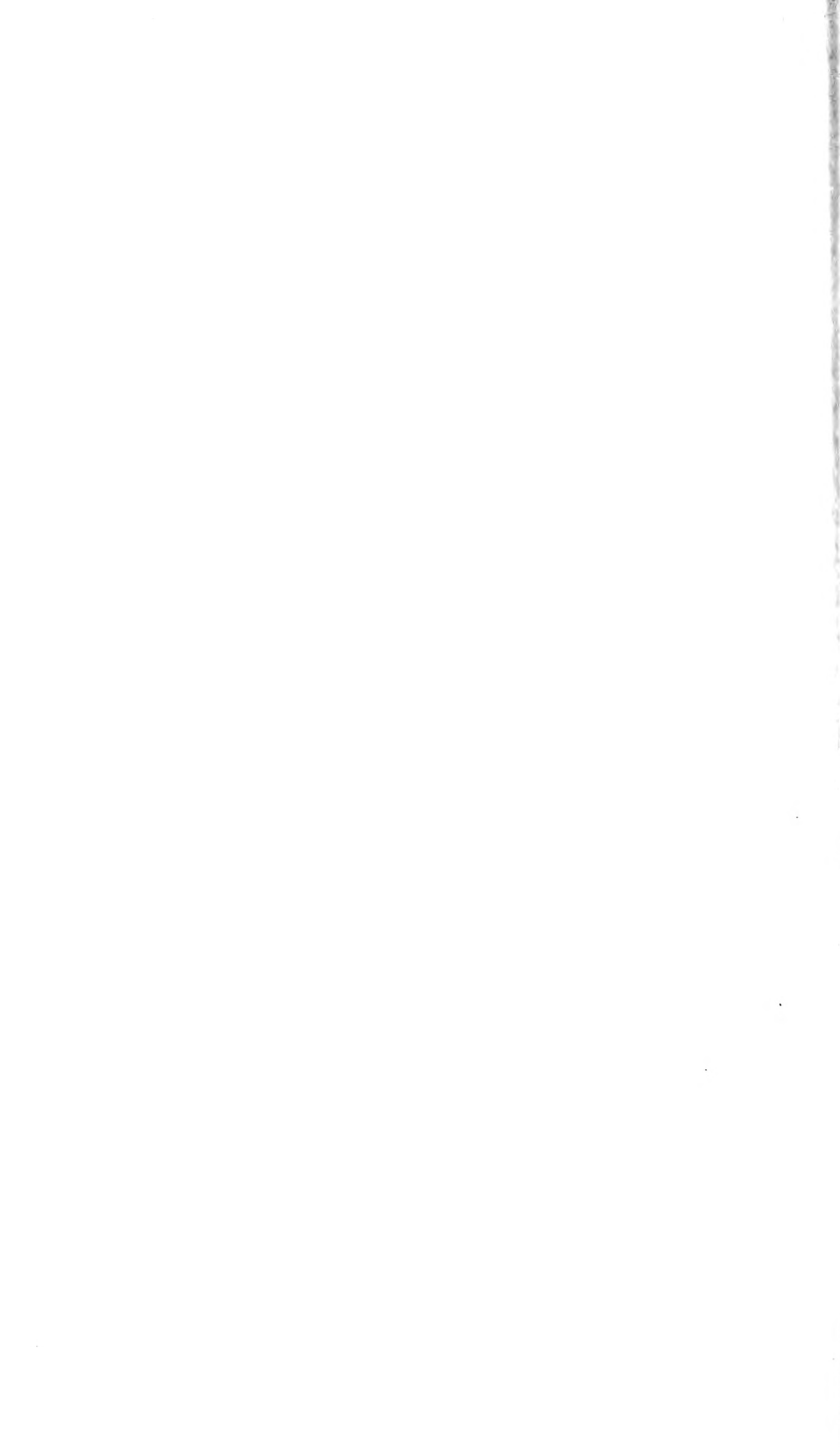

No. 18,139

United States Court of Appeals

For the Ninth Circuit

UNITED STATES OF AMERICA,
Libelant-Appellant,

vs.

1200 CANDY BARS, MORE OR LESS,
LABELED IN PART "STA-TRIM,"
Defendant-Respondent,

and

STA-TRIM CONFECTIONS, INC.,
Claimant-Appellee.

Appeal from the United States District Court,
Northern District of California, Southern Division.
Honorable William T. Sweigert, Presiding.

APPELLANT'S REPLY BRIEF

Appellee exhibits in its brief a most regrettable inaccuracy in the statement of facts. It utilizes the technique of drawing erroneous conclusions from erroneous premises. It sets up straw men and then demolishes them. We are therefore obliged, in this Reply Brief, to call the Court's attention to several major examples of this propensity.

1. Contrary to Appellee's Implication, the Government's Position Here Is Consistent With the Administrative Interpretation of Section 342(d) Maintained by the Food and Drug Administration Since the Enactment of That Section.

The following quotation is taken from page 13 of Appellee's brief and is a good illustration of the technique alluded to above:

"It is not without significance to note that since the enactment of Section 342(d), the Food and Drug Administration has itself applied this section only to nonnutritive substances which were inedible or harmful. For example, this section has been applied to the use in confectionery of such non-nutritive substances as carnauba wax, shellac and sodium bisulphite. [Food and Drug Administration Trade Correspondence 317, August 20, 1940; Food and Drug Administration Trade Correspondence 238, April 11, 1960; (both reported in CCH Food, Drug and Cosmetic Act Reporter).] However, in the case of stearic acid, the Food and Drug Administration has ruled that Section 342(d) does not apply since stearic acid is an *edible* nonnutritive substance. (Food and Drug Administration Trade Correspondence 238, April 11, 1940.)"

In this paragraph, Appellee seeks to create the impression that the Food and Drug Administration has heretofore taken the position now espoused by Appellee and has deemed Section 342(d) to apply only to non-nutritive substances which are *inedible or harmful*. Nothing could be further from the truth as we will demonstrate shortly. To prove its point, Appellee *paraphrases* an administrative interpretation of this section with respect to stearic acid as a ruling "*that Section 342 (d) does not apply since stearic acid is an edible non-*

nutritive substance." So that the Court may have a true picture, we quote the relevant portion of this administrative interpretation as it is reported in *Kleinfeld and Dunn*, Federal Food, Drug, and Cosmetic Act 1938-1949, pages 662-3 (CCH 1949):

"Correspondent asks whether it is permissible to coat confectionery with edible grades of stearic acid.

"*The prohibition* in Section 402(d) of the Act [21 U.S.C. 342(d)] against glaze in confectionery in excess of 0.4 per cent *applies only to a nonnutritive substance.* In the case of edible stearic acid, the 0.4 per cent limitation would not apply, since it is not a resinous glaze *nor is it nonnutritive.* Its addition to confectionery would, however, be subject to the general provisions of the Act. . . ." (Emphasis added.)

In the foregoing statement, the Food and Drug Administration unequivocally declared that stearic acid is *not* a nonnutritive substance. Yet Appellee paraphrases this statement to convey the opposite meaning. Why does Appellee do this? To give emphasis to the word "edible" so as to create the false impression that the Food and Drug Administration has construed Section 342(d) to apply only to nonnutritive substances which are inedible or harmful.

There are various grades of stearic acid, some of which are suitable for human consumption and some of which are less pure and are therefore suitable only for industrial uses such as in the production of candles, phonograph records, insulators, modeling compounds, etc. See *The Merck Index* (Seventh Edition, 1960), pages 976-7. Obviously, confectionery is a food which

should contain only edible substances, but the applicability of Section 342(d) hinges exclusively upon the *non-nutritive quality* of the substances or the presence of alcohol. Another provision of the law deals specifically with foods which are unfit for human consumption. [21 U.S.C. 432(a)(3).]

In the above quoted statement from page 13 of Appellee's brief, there is also reference to carnauba wax, shellac, and sodium bisulphite with the implication that these substances are excluded from confectionery through the operation of Section 342(d) because they are inedible and harmful as well as nonnutritive. This is not true. Insofar as these substances are excluded by Section 342(d), the sole test is their nonnutritive character, except that the statutory exemption for glaze specifies that the glaze must be "harmless." We quote the administrative rulings as reported in *CCH Food, Drug, Cosmetic Law Reporter*, page 3198, paragraph 3036:

Carnauba Wax

"So far as we are aware, carnauba wax is to be classed as a nonnutritive substance under the new Food, Drug, and Cosmetic Act, and since it is not included in the list of exempted nonnutritive articles in Section 402(d) of the Act, it will not be a proper ingredient of confectionery under the new Act." TC-238, April 11, 1940.

Shellac

"Under section 402(d) confectionery may contain harmless resinous glaze not in excess of four-tenths of one percentum. Shellac used in confec-

tionery is classed as a harmless resinous glaze, provided it is free from poisonous or deleterious impurities." . . . TC-238, April 11, 1940.

Sodium Bisulphite

" . . . Since that time further consideration has been given to the status of sodium bisulphite in confectionery and the conclusion reached that this chemical is a nonnutritive substance and, therefore, under the provision of section 402(d) of the Food, Drug, and Cosmetic Act may not be used in confectionery in any amount." TC-317, August 20, 1940.

These rulings speak for themselves and clearly belie Appellee's assertions.

2. The Government Does Not Disavow the Testimony of Mr. Campbell.

In our opening brief (pages 21-25), we referred to the legislative history of Section 342(d), citing the testimony of Mr. Campbell who was then the Chief of the Food and Drug Administration to support our position that when Congress used the term "nonnutritive substance" it meant just that, nothing more or less. We also cited unsuccessful efforts made by Mr. Heide, a representative of the confectionery industry, to cut down the scope of the confectionery provisions of the bill then before Congress. Mr. Heide's suggestions show that he completely agreed with Mr. Campbell that the exclusion of nonnutritive substances from confectionery would be absolute, and he therefore proposed the use of more limiting language.

However, on page 12 of Appellee's brief, *after quot-*

ing only portions of Mr. Campbell's relevant testimony, there appears the following statement with reference to this segment of the legislative history:

“In the first place, *it is disturbing* to say the least, that the appellant seeks to disavow the very explicit statement of its own Chief of the Food and Drug Administration with reference to the meaning of ‘nonnutritive substance’ and to rely upon the statement of one who was neither a proponent nor draftsman of the bill.” (Emphasis added.)

Appellee is needlessly disturbed since the Government does not disavow Mr. Campbell's testimony but relies on *all* of it, including the portion overlooked by Appellee where Mr. Campbell urged a special exemption for chewing gum lest it become an illegal product because of the all-inclusive ban against any nonnutritive substance. (See page 22 of our opening brief.)

3. The Government's Interpretation of Section 342(d) Is Not in Conflict With Section 343(j).

On pages 15-18 of Appellee's brief, the assertion is made that the Government's interpretation of Section 342(d) is in conflict with Section 343(j). Through Section 343(j) and the regulations authorized thereunder (21 CFR § 125), Congress has undertaken to regulate the labeling of foods which are promoted for special dietary uses—i.e., infant foods, low sodium foods, foods used in control of body weight or in dietary management with respect to disease, foods containing nonnutritive constituents, etc.

Section 343(j) reads:

“A food shall be deemed to be misbranded if it purports to be or is represented for special dietary

uses, unless its label bears such information concerning its vitamin, mineral, and other dietary properties as the Secretary determines to be, and by regulations prescribes as, necessary in order fully to inform purchasers as to its value for such uses."

The purpose of this Section is fully to inform purchasers of special dietary foods as to the real value of the foods for the purposes for which they are offered. Obviously, it is designed to help prevent consumer deception, not to foster and facilitate it.

By this statute and the regulations promulgated under it, general provision is made for the marketing of certain classes of food containing nonnutritive constituents. (See 21 CFR § 125.7 and § 1.11.) But through Section 342 (d), Congress has declared that confectionery shall not contain nonnutritive substances, *regardless of whether it is offered as a special dietary food.*

Appellee cites *U. S. v. 62 Cases of Jam*, 340 U.S. 592 (1951). There the issue was whether a product which purported to be jam but did not conform to the administrative standard for jam could legally be marketed under the name "Imitation Jam." The Court held that one section of the law [403(c)] expressly authorized use of the "Imitation" label on *any* food which imitated another, and that there was no provision which expressly prohibited use of the "Imitation" label on a food which imitated a standardized food. On page 600, the Court said:

"We could hold it to be 'misbranded' only if we held that a practice Congress authorized by § 403 (c) Congress *impliedly* prohibited by § 403(g)." (Emphasis added.)

In other words, the general authorization in one section of the law to use the "Imitation" label could not be curtailed by an *implied* prohibition in another section of the law. But the Supreme Court went on to say that it was within the power of Congress to cut down the scope of the general authorization by an *express* limitation:

"If Congress wishes to say that nothing shall be marketed in likeness to a food as defined by the Administrator, though it is accurately labeled, entirely wholesome, and perhaps more within the reach of the meager purse, *our decisions indicate that Congress may well do so. But Congress has not said so.*" (Emphasis added.)

In the instant case, on the other hand, Congress has affirmatively chosen to deal with the composition of confectionery in Section 342(d) and has *expressly* excluded nonnutritive substances from confectionery. In Section 343(j) Congress generally authorized the marketing of foods with special dietary properties, but in Section 342(d) Congress specifically prohibited the use of nonnutritive ingredients in confectionery, whether or not the confectionery is dressed up as a food "for special dietary uses." This is clearly within the Congressional power under the *Jam* case, *supra*. See also *Federal Security Administrator v. Quaker Oats Co.*, 318 U.S. 218 (1943), and *Carolene Products Co. v. U. S.*, 140 F.2d 61, 65 (C.A. 4, 1944), affirmed 323 U.S. 18 (1944).

Consequently, when the administrative regulations under Section 343(j) state that the regulations dealing with nonnutritive constituents do not relieve any food from complying with Section 342(d) or other provisions

of the law (21 CFR 125.7), they merely call attention to a policy which *Congress* enacted into law. The classification distinguishing confectionery from other foods was made by Congress and not by the administrative body.

4. Sta-Trim Candy Bars Are Not Low Calorie Products.

On pages 15-20 of its brief, Appellee repeatedly refers to the Sta-Trim bars under seizure in this case as low calorie confections and low calorie candies, despite the District Court's adjudication that the term "low calorie" is false and misleading when applied to these candy bars.

In the Decree of Condemnation, the District Court said in part (R. 90):

"ORDERED, ADJUDGED AND DECREED that the said article under seizure is in violation of 21 U.S.C. 343(a) and (g) as alleged in the Amended Libel, and is therefore hereby condemned pursuant to 21 U.S.C. 334(a) . . ."

And the Amended Libel alleged in part (R. 15):

"The aforesaid article was misbranded when introduced into and while in interstate commerce within the meaning of said Act, as follows:

"21 U.S.C. 343(a) in that the label statements 'Low Calorie,' 'Good for you when you diet—Good for you when you want to keep trim,' and 'For People Who Want To Keep Trim,' are false and misleading since the article is not low in calories and will not be effective to reduce weight or to keep trim . . ."

Since Appellee is not challenging the District Court's adjudication that the product is misbranded as alleged,

it has no basis whatsoever for using the term "low calorie" to describe its product.

5. Appellee's References to the Question of an Interlocutory Appeal Are Confusing.

In the Court below, there were three different rulings with respect to whether an interlocutory appeal was appropriate at an early stage of the proceeding. Those rulings have no bearing on the present appeal. Yet Appellee on page 4 of its brief chooses to quote from the first of those rulings, knowing that the District Court subsequently set that ruling aside. To clear up any possible misconceptions, we think it best to cite all of the Court's rulings on this point:

R. 78

"This lawsuit would not be ended even if summary judgment were entered in favor of libelant on the issue of adulteration. There still remains the issue of misbranding which involves questions of fact to be tried. The adulteration issue does not present a controlling question of law because both issues are separate and independent of each other. For these reasons, the Court is unable to certify this matter to the appellate court under Section 1292 (b)."

R. 83

"Upon further consideration, however, it appears that a summary judgment in favor of libelant on the issue of adulteration would dispose of the case."

R. 84

"The Court is of the opinion that its ruling on the adulteration issue involves a controlling ques-

tion of law as to which there is substantial ground for difference of opinion and that an immediate appeal from the order to be entered thereon may materially advance the ultimate termination of the litigation.”

R. 85-86

“IT IS THE FURTHER ORDER of this Court, in view of the strong policy against piecemeal appeals, and because the remaining issue of misbranding may be tried in several days, that the Supplemental Opinion of this Court, dated July 12, 1961, indicating the Court’s willingness to certify this matter for an interlocutory appeal under Section 1292(b) of Title 28, United States Code, be set aside, and this matter proceed to trial forthwith.”

The arguments made in Appellee’s brief are irrelevant and without merit. Again we urge that this Court take the course of action proposed on pages 38 and 39 of our opening brief.

Respectfully submitted,

CECIL F. POOLE,
United States Attorney.

ROBERT N. ENSIGN,
Assistant United States Attorney.

Attorneys for Appellant.

ARTHUR A. DICKERMAN,
Attorney, Department of Health,
Education and Welfare.

Of Counsel.

CERTIFICATE

I certify that, in connection with the preparation of this brief, I have examined Rules 18 and 19 of the United States Court of Appeals for the Ninth Circuit, and that, in my opinion, the foregoing brief is in full compliance with those rules.

Attorney.



TOPICAL INDEX

| | PAGE |
|--|------|
| I. | |
| Jurisdictional statement | 1 |
| II. | |
| Statement of the case..... | 2 |
| III. | |
| Specifications of errors..... | 4 |
| IV. | |
| Summary of argument..... | 4 |
| V. | |
| Argument | 6 |
| 1. Whether a taxpayer has any "rights to property" to which a federal tax lien can attach is a question to be determined by applicable state law..... | 6 |
| 2. Under applicable California law cross-demands are deemed compensated so that under the facts of the instant case there was no property or rights to property of the taxpayer in the possession of the bank to which the United States tax liens could attach..... | 14 |
| 3. The government had no enforceable lien upon the checks deposited by the taxpayer or upon the proceeds collected by the bank by the use of the checks..... | 18 |
| 4. The decision in <i>Bank of Nevada v. United States</i> is distinguishable from the instant case and is inconsistent with later Supreme Court decisions..... | 20 |
| Conclusion | 23 |

TABLE OF AUTHORITIES CITED

| CASES | PAGE |
|---|------------------|
| Aquilino v. United States, 361 U. S. 501, 4 L. Ed. 2d 1365, 80 S. Ct. 1227..... | 6, 21, 22 |
| Bank of Nevada v. United States, 251 F. 2d 820.... | 5, 20, 21, 22 |
| Chicago Federal S. & L. Assn. v. Cacciatore, Sept. 28, 1962, Docket No. 37093 (62-2 U. S. T. C. p. 85999, par. 9739).... | 13 |
| Crest Finance Co. Inc. v. United States, 368 U. S. 347, 7 L. Ed. 2d 342, 82 S. Ct. 384..... | 17 |
| Everett v. Judson, 228 U. S. 474, 57 L. Ed. 927, 33 S. Ct. 568 | 13 |
| Goggin v. Bank of America, 183 F. 2d 323..... | 14 |
| Gonsalves v. Bank of America, 16 Cal. 2d 169, 105 P. 2d 118.. | 15, 20 |
| Halprin, In re, 280 F. 2d 407..... | 9, 10, 21 |
| Nelson v. Bank of America, 76 Cal. App. 2d 501, 173 P. 2d 322 | 16 |
| Pendleton v. Hellman Commercial T. & S. Bank, 58 Cal. App. 448 | 16 |
| People v. Main, 75 Cal. App. 471, 243 P. 2d 1078..... | 17 |
| United States v. Bess, 357 U. S. 51, 2 L. Ed. 1135, 78 S. Ct. 1054 | 7, 8, 14, 21, 22 |
| United States v. Brosnan, 363 U. S. 237, 4 L. Ed. 2d 1192; 80 S. Ct. 1108..... | 13 |
| United States v. Graham, 96 Fed. Supp. 318, aff'd, State of California v. United States, 195 F. 2d 530..... | 22 |
| United States v. Hutcherson, 188 F. 2d 326..... | 11 |
| United States v. Manufacturers Trust Co., 198 F. 2d 366..... | 10 |
| United States v. Metropolitan Life Insurance Co., 130 F. 2d 149 | 10 |

| | PAGE |
|---|------|
| United States v. The American National Bank of Jacksonville, 255 F. 2d 504..... | 11 |
| Walter v. Bank of America, 59 P. 2d 983..... | 16 |
| Wolverine v. Phillips, 165 Fed. Supp. 335..... | 12 |

STATUTES

| | |
|---|--------|
| Code of Civil Procedure, Sec. 440 | 14, 20 |
| Revenue Ruling 57-367, I. R. B. 1957, 32, 22..... | 19, 22 |
| National Bankruptcy Act, Sec. 70(a)..... | 14 |
| United States Code, Title 26, Sec. 6323..... | 22 |
| United States Code, Title 26, Sec. 6323(c)..... | 18 |
| United States Code, Title 26, Sec. 6332(b)..... | 2 |
| United States Code, Title 26, Sec. 7401..... | 2 |
| United States Code, Title 28, Sec. 1291..... | 2 |
| United States Code, Title 28, Sec. 1340..... | 1 |
| United States Code, Title 28, Sec. 1345..... | 2 |

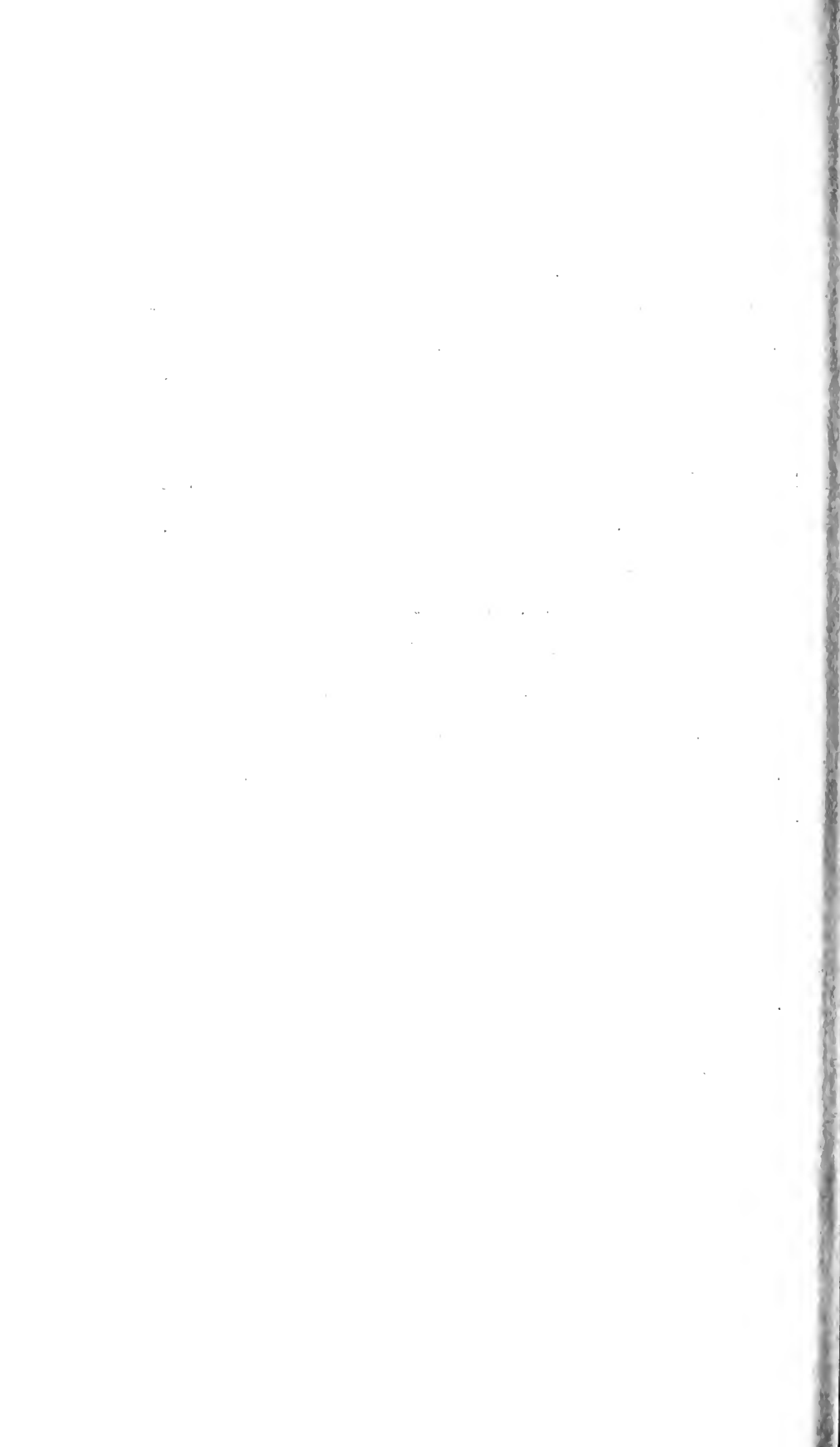

No. 18142

IN THE

United States Court of Appeals

FOR THE NINTH CIRCUIT

BANK OF AMERICA NATIONAL TRUST AND SAVINGS
ASSOCIATION, a national banking association,

Defendant-Appellant,

vs.

UNITED STATES OF AMERICA,

Plaintiff-Appellee.

APPELLANT'S OPENING BRIEF.

I.

JURISDICTIONAL STATEMENT.

The United States at the request of the Commissioner of Internal Revenue sued the Bank of America seeking a money judgment for \$6,658.31 [R. 3-6, 25, 26]. The principal amount sued for is equal to the amount which stood, on the Bank's books, to the credit of one J. B. Edmondson in commercial and savings accounts at the time the District Director of Internal Revenue caused to be served upon the Bank a notice of levy in an attempt to collect delinquent taxes owed by Edmondson to the Government.

The jurisdiction of the United States Distirct Court was invoked pursuant to Title 28, Sections 1340 and

1345, and Title 26, Sections 7401 and 6332(b) of the United States Code.

Both plaintiff and defendant moved for summary judgment and the plaintiff's motion was granted. Within the time allowed by the law the Bank appealed [R. 32]. The jurisdiction of the United States Court of Appeals was invoked pursuant to the provisions of Section 1291, Title 28, United States Code.

II.

STATEMENT OF THE CASE.

In July, August and October, 1955, the Director of Internal Revenue made three assessments against the taxpayer, J. B. Edmondson, for delinquencies arising in 1955. Notice of one of these liens was filed in Orange County on October 19, 1955, and notices of the other two liens were filed in that County in January, 1958 [Finding 2(e), R. 26-27]. No demand for the payment of these taxes was ever made upon the defendant Bank prior to August 27, 1959, and the Bank had no knowledge prior to that date of the existence of any United States tax lien against property or rights to property of J. B. Edmondson [R. 19].

In March and September, 1958, and in March of 1959 Edmondson purchased automobiles on conditional sale contracts. The seller's interest in the contracts was assigned to the defendant Bank. At some time prior to August 27, 1959, Edmondson had borrowed money from the Bank on two separate loans. One of the loans was secured by a mortgage on a boat and

the other was evidenced by an unsecured promissory noted [Findings 2(i), (j) and (k), R. 28].

On August 27, 1959, there was a total balance due from Edmondson to the Bank on the conditional sale contracts of \$9,161.26. On the same date there was due from Edmondson to the Bank the sum of \$1,179.14 on the boat loan. On the unsecured note Edmondson owed \$1,230.10, which balance was also due to the Bank on that date. The total indebtedness due from Edmondson to the Bank on August 27, 1959, was, therefore, \$11,570.50 [Finding 2(1), R. 29].

Within the few weeks immediately preceding August 27, 1959, Edmondson deposited in various accounts which he maintained with the Bank certain checks [R. 22-23]. As a result of these deposits the Bank's books showed a credit on August 27, 1959, in accounts standing in the name of J. B. Edmondson of \$6,658.31. [R. 27].

On August 27, 1959, the District Director of Internal Revenue served upon the Bank, for the first time, a notice of levy purporting to levy upon all property or rights to property belonging to the taxpayer, J. B. Edmondson. The notice demanded surrender by the defendant Bank of all property or rights to property, monies, credits and bank deposits then in its possession and "belonging to the taxpayer" and all sums or other obligations owing from the defendant Bank to the taxpayer. The Bank refused to honor this demand [R. 27-28]. The United States then sued.

Both the government and the Bank moved for summary judgment. The Trial Court granted the government's motion and indicated in his comments that banks should be under a duty to examine county lien records before making loans or accepting deposits from their customers [R. 30]. From this judgment the Bank appealed.

III.

SPECIFICATIONS OF ERRORS.

The Trial Court's judgment was contrary to law because:

1. United States tax liens attach only to property or rights to property of the taxpayer, and under federal law the existence and the extent of the "property and rights to property of the taxpayer" is determined by state law.

2. Under California law cross-demands "shall be deemed compensated," so that under the facts of this case there was no "property or rights to property" of the taxpayer in the possession of the Bank to which United States tax liens could attach.

IV.

SUMMARY OF ARGUMENT.

1. Whether a taxpayer has any rights to property to which a federal tax lien can attach is a question to be determined by applicable state law. The rights of the government rise no higher than the rights of the taxpayer against the Bank and are no broader in scope.

2. Under applicable California law cross-demands are deemed compensated so that under the facts of the instant case there was no property nor rights to property of the taxpayer in the possession of the Bank to which United States tax liens could attach.

(a) Since Edmonson owed the Bank \$11,570.50 on the date of the levy and the Bank owed Edmondson at that time only \$6,658.31, the net balance owing from Edmondson to the Bank on the date of the levy was \$4,812.19. Under California law the Bank had the right to set off the balances owing by it to Edmonson against the balances owing by Edmondson to the Bank.

(b) The Bank's right of setoff was completely choate on the date of the levy since all that the Bank had to do in order to enforce its right of setoff was to refuse to pay money which it did not owe to Edmondson or to the government.

3. The government had no enforceable lien upon the checks deposited by the taxpayer or upon the proceeds collected by the Bank by the use of the checks.

4. The decision in *Bank of Nevada v. The United States* is distinguishable from the instant case and is inconsistent with later Supreme Court decisions.

V.

ARGUMENT.

1. Whether a Taxpayer Has Any "Rights to Property" to Which a Federal Tax Lien Can Attach Is a Question to Be Determined by Applicable State Law.

In *Aquilino v. United States*, 361 U. S. 501, 4 L. Ed. 2d 1365, 80 S. Ct. 1227 (1960) the Court said (L. Ed. p. 1368):

"The threshold question in this case, as in all cases where the Federal Government asserts its tax lien, is whether and to what extent the taxpayer had 'property' or 'rights to property' to which the tax lien could attach. In answering that question, both federal and state courts must look to state law, for it has long been the rule that 'in the application of a federal revenue act, state law controls in determining the nature of the legal interest which the taxpayer had in the property . . . sought to be reached by the statute.' *Morgan v. Commissioner*, 309 U. S. 78, 82, 84 L. Ed. 585, 589, 60 S. Ct. 424. Thus, as we held only two terms ago, Section 3670 'creates no property rights but merely attaches consequences, federally defined, to rights created under state law . . . ' *United States v. Bess*, 357 U. S. 51, 55, 2 L. ed. 2d 1135, 1140, 78 S. Ct. 1054."

In other words, it is only after a United States tax lien has attached to legally enforceable property interests of the taxpayer, as determined by the applicable state law, that we enter into the province of federal law to determine the priority and consequences of competing liens.

An excellent discussion of the principles applicable to the decision in the instant case is found in *United States v. Bess*, 357 U. S. 51, 2 L. Ed. 2d 1135, 78 S. Ct. 1054 (1958). There the Court was confronted with the question of the extent, if any, to which United States tax liens attached to the proceeds of life insurance policies payable to the wife of the taxpayer as beneficiary in the situation where the taxpayer had died after the lien was perfected. The Court held (1) that the United States tax liens attached only to "property and rights to property" of the taxpayer and (2) that the rights of the beneficiary under the policy were to be determined under state law. Applying these principles the Court said (L. Ed. p. 1140):

"We must now decide whether Mr. Bess possessed in his lifetime, within the meaning of §3670, any 'property' or 'rights to property' in the insurance policies to which the perfected lien for the 1946 taxes might attach. Since §3670 creates no property rights but merely attaches consequences, federally defined, to rights created under state law, *Fidelity & Deposit Co. v. New York City Housing Authority* (CA2 NY) 241 F2d 142, 144, we must look first to Mr. Bess' right in the policies as defined by state law.

"(a) It is not questioned that the rights of the insured are measured by the policy contract as enforced by New Jersey law. Manifestly the insured could not enjoy the possession of the proceeds in his lifetime. His right to change the beneficiary, even to designate his estate to receive the proceeds, gives him no right to receive the proceeds while he lives. Cf. *Rowen v. Commis-*

sioner (CA2) 215 F2d 641, 644. It would be anomalous to view as 'property' subject to lien proceeds never within the insured's reach to enjoy, and which are reducible to possession by another only upon the insured's death when his right to change the beneficiary comes to an end. We therefore do not believe that Mr. Bess had 'property' or 'rights to property' in the proceeds, within the meaning of §3670, to which the federal tax lien might attach. *Cannon v. Nicholas* (CA10 Colo) 80 F2d 934; see *United States v. Burgo* (CA 3 NJ) 175 F2d 196. This conclusion is in harmony with the decision in *Everett v. Judson*, 228 US 474, 57 L ed 927, 33 S CT 568, 46 LRA NS 154, that the cash surrender value of a policy on the life of a bankrupt is the extent of the property which is vested in the trustee under §70a of the Bankruptcy Act."

Paraphrasing the language of the Supreme Court as applied to the instant case, it would be anomalous to view as property subject to lien, proceeds never within Edmondson's reach to enjoy, and which are reducible to possession only upon Edmondson's discharge of his accrued indebtedness to the Bank. In *Bess* the condition precedent to the taxpayer's right to compel the insurance company to pay the full face amount of the property was his death; in the instant case the condition precedent to Edmondson's right to compel the Bank to pay its debt to him was the discharge of his debt to the Bank. It seems obvious that if Mr. Bess had borrowed money from the insurance company against the cash surrender value of his policies, the government's lien rights against the cash surrender value

would be reduced by an amount equal to the amount the taxpayer had previously borrowed. So also in the instant case, having borrowed money from the Bank and become obligated to the Bank, it seems apparent that the government's lien in the instant case attaches only to a chose in action which is completely defeated by the existence of the Bank's counterclaim.

Many other illustrations of the applicability of these sound principles are available.

In *In re Halprin*, 280 F. 2d 407 (3d Cir. 1960), it appeared that after the filing of a United States tax lien against *Halprin* he borrowed money and assigned to the lender monies to become due him under an executory contract for the sale of merchandise. In ruling that there was no "property or rights to property" subject to the United States tax lien, the Court said (p. 410):

"From a somewhat different approach, such a lender as Commercial has enriched the taxpayer's estate by the amount loaned to the taxpayer. For this reason, it is not unreasonable to allow it a corresponding security interest in the fruit of the borrowed money, with the government relegated to the borrowing taxpayer's net after the lender is reimbursed. The government has suffered no diminution of the assets which were available to satisfy its tax claim before the loan. In addition, if the tax collector should seize the borrowed funds before their expenditure he could do so.

"For these reasons we conclude that Doniger's promise to pay for goods if and when delivered, as stated in an executory bilateral contract did not constitute 'property . . . belonging to' Halprin,

subject to a tax lien under Section 6321. Later, when goods were manufactured and delivered to Doniger, his unqualified obligation to pay, as it then came into existence, ran solely to Commercial and thus could not be reached by any lien on Halprin's property."

In other words, neither Halprin, nor Edmondson in the instant case, ever had any right to receive the funds.

Applying the approach of the Court of Appeals for the Third Circuit to the instant situation, it becomes apparent that the Bank has actually enriched the taxpayer's estate by the amount of funds advanced to him. As the Court said in *Halprin, supra*;

"For this reason it is not unreasonable to allow it a corresponding security interest in the fruit of the borrowed money, with the government relegated to the borrowing taxpayer's net after the lender is reimbursed."

Another way of expressing the thought that United States liens attach only to the property of the taxpayer is found in *United States v. Manufacturers Trust Co.*, 198 F. 2d 366 (2d Cir. 1952), where the Court ruled (p. 367):

"The distraint, at most, gave the government the rights of a judgment creditor who has levied upon the depositor's property, *United States v. Warren R. Co.*, 2 Cir., 127 F. 2d 134, and, as such, the government obtained no greater rights than the depositor."

In *United States v. Metropolitan Life Insurance Co.*, 130 F. 2d 149 (2d Cir. 1942), the government sought to reach the cash surrender value of an insurance policy

on the life of the taxpayer. The Court in an opinion by Circuit Judge Learned Hand held that the taxpayer's claim was not property of the taxpayer in the possession of the insurance company which the insurance company "surrendered" by paying. Judge Hand said (p. 151):

" . . . Certainly the section gives no evidence of any purpose to allow the United States to mend in the District Court all infirmities of title in the taxpayer's property. The diction, the setting and the purpose of the section unite to deny the plaintiff's interpretation of the word 'property.' "

So also in the instant case the government is not entitled to mend the "infirmity" in Edmondson's position which arises inevitably from the Bank's counterclaim.

In *United States v. The American National Bank of Jacksonville*, 255 F. 2d 504 (5th Cir. 1958), the Court held that where title to real property was held by the taxpayer and his wife as tenants by the entirety, the taxpayer had no property interest in the land to which the tax lien could attach and therefore a mortgage given to the Bank by the taxpayer and his wife after the tax lien was filed took precedence over the government's claim. The reasoning of the Court was that the individual interest of the husband or wife in an estate by the entirety was not such an estate as may be subjected to the grasp of an attaching creditor or which would permit the adherence of a tax lien. The Court, quoting from *United States v. Hutcherson*, 188 F. 2d 326, 331 (8th Cir. 1951), said that it was not at liberty to change the nature of the estate for the benefit of the government.

In *Wolverine v. Phillips*, 165 F. Supp. 335 (N. D. Iowa, 1958), the controversy was between the surety on a bond of a defaulting building contractor and the government as holder of tax liens against the contractor. It was held that where the contractor breached his contract with the owner before the balance of money became due so that the contractor had no enforceable right against the owner to recover the balance, the federal government was not entitled to the balance paid into escrow and such balance was payable to the surety. The Court said (p. 353):

“Therefore in the present case in order for the government’s tax liens to be of avail to it there must at some time have been created under state law some enforceable right in behalf of the contractor against the owner for money due under the contract. As heretofore noted at the time the tax liens arose, the contractor had already been paid the progress payments and the only money that could thereafter be due it would be the money due it upon the completion of the contract. Before that latter event occurred the contractor had committed a breach of contract, the damages for which amount to \$19,248.02.”

So also in the instant case the only money that the Bank could be compelled to pay to Mr. Edmundson would be money due him upon full payment of his obligations to the Bank which were due. Before payment by the Bank of the funds standing to Edmondson’s credit in the bank account, Edmondson would, under the law, be required to discharge his obligations to the Bank.

The most recent well-considered discussion of this problem is found in *Chicago Federal S. & L. Assn. v.*

Cacciatore, decided by the Supreme Court of Illinois September 28, 1962, Docket No. 37093 (62-2 USTC, p. 85999, par. 9739). In that case the Court held that even though the federal tax lien had been filed prior to the recording of a second deed of trust, the government had no interest in the real estate held in trust for the benefit of the taxpayer. The government contended that since the taxpayer at the time of the lien was in a position and had a legal right to withdraw the real estate from the trust and receive the property back subject only to the first trust deed, the government had the same right. The Court pointed out that the government did not bring a creditor's bill or take other action seeking assertion of this right at any time prior to the recording of the second deed of trust, and since it did not do so it was junior to the second deed of trust.

The Supreme Court of Illinois relied heavily upon *United States v. Brosnan*, 363 U. S. 237, 4 L. ed. 2d 1192, 80 S. Ct. 1108 (1960), where the Supreme Court held that a government tax lien was wiped out by a foreclosure under a power of sale in accordance with California law, stating that long accepted non-judicial means of enforcing private liens as established by state law constitute an acceptable method of wiping out or nullifying a federal tax lien.

By analogy a trustee in bankruptcy obtains no greater rights against debtors of the bankrupt than the bankrupt had. The trustee takes choses in action owned by the bankrupt subject to all defects and defenses which could be asserted by the defendant against the bankrupt. For example, in *Everett v. Judson*, 228 U. S. 474, 57 L. Ed. 927, 33 S. Ct. 568 (1913), the

Supreme Court held that only the cash surrender value of a policy on the life of a bankrupt vests in the trustee under Section 70(a) of the National Bankruptcy Act. This case was cited and relied upon by the Supreme Court in *United States v. Bess, supra*, 357 U. S. 351. This Court in *Goggin v. Bank of America*, 183 F. 2d 323 (9th Cir. 1950), also held that the Bank's right of setoff was in effect and could be asserted as against the bankruptcy trustee, and the trustee's rights were not enlarged by virtue of Sections 60 and 70 of the National Bankruptcy Act. It seems logically to follow that if the trustee's rights can rise no higher than the rights of the bankrupt, the government's rights as a creditor of the taxpayer can rise no higher than the taxpayer's rights.

2. Under Applicable California Law Cross-Demands Are Deemed Compensated so That Under the Facts of the Instant Case There Was No Property or Rights to Property of the Taxpayer in the Possession of the Bank to Which the United States Tax Liens Could Attach.

Section 440 of the California Code of Civil Procedure provides:

“When cross-demands have existed between persons under such circumstances that, if one had brought an action against the other, a counterclaim could have been set up, the two demands shall be deemed compensated so far as they equal each other, and neither can be deprived of the benefit thereof by the assignment or death of the other.”

In other words, under California law cross-demands automatically compensate each other. No action to effect an offset is required of the parties. By operation of law one claim offsets the other.

A complete discussion of the nature of the right of offset is found in *Gonsalves v. Bank of America*, 16 Cal. 2d 169, 105 P. 2d 118 (1940), where the Court said (p. 173):

“To understand this exercise of the bank’s right it is necessary to state briefly its nature. Section 3054 of the Civil Code provides: ‘A banker has a general lien, dependent on possession, upon all property in his hands belonging to a customer, for the balance due to him from such customer in the course of the business.’ The banker’s lien described in this statute is, properly speaking, a lien on the *securities* such as commercial paper deposited with the bank by the customer in the course of business. The so-called ‘lien’ of the bank on the depositor’s *account* or funds on deposit is not technically a lien, for the bank is the owner of the funds and the debtor of the depositor, and the bank cannot have a lien on its own property. The right of the bank to charge the depositor’s fund with his matured indebtedness is more correctly termed a right of setoff, based upon general principles of equity. See *Pendleton v. Hellman Commercial T. & S. Bank*, 58 Cal. App. 448 [208 Pac. 702]; 11 Cal. L. Rev. 111, 112; 7 Cal. L. Rev. 341; 38 Harv. L. Rev. 800; Brown on Personal Property, p. 519.

“This right of setoff, however, is not limited in its exercise to the pleading of a counterclaim

in an action. Despite the technical inaccuracy involved in calling it a lien, it is in the nature of a lien or security interest in the funds, similar to and enforceable in the same way as the lien against commercial paper. *That is to say, it is enforceable by the bank's own act, without the aid of a court.* Cases illustrating this exercise of the right of setoff without any action pending are readily found. (See *Pendleton v. Hellman Commercial T. & S. Bank, supra*; *Mt. Sterling Nat. Bank v. Green*, 99 Ky. 262 [35 S. W. 911, 32 L. R. A. 568]; 38 Harv. L. Rev. 800, 801) . . . And in *Pendleton v. Hellman Commercial T. & S. Bank, supra*, the court said (p. 452): 'But in the case at bar the defense presented is not in the nature of a counterclaim. *Its allegations are, in effect, that there exists no indebtedness of the defendant to the plaintiff.* The bank is not seeking to collect its note from the decedent's estate . . . Appellant's claim here is that by reason of the insolvency of Pendleton, it was entitled to apply the amount of the deposit *pro tanto* to the payment of the note.'” (Emphasis ours).

Simply stated, the Bank's position is, as the Court said in *Pendleton v. Hellman Commercial T. & S. Bank*, 58 Cal. App. 448, that *there existed no indebtedness of the Bank to Edmondson.*

The right of offset exists even though the party exercising the right holds security. *Walters v. Bank of America*, 59 P. 2d 983 (1936) (decision in S. Ct., 9 Cal. 2d 46); *Nelson v. Bank of America*, 76 Cal. App. 2d 501, 173 P. 2d 322 (1946). The Bank's right of offset was completely choate at all times material,

that is, before, at and after the time of the levy, because the right exists by operation of law. In *Crest Finance Co. Inc., v. United States*, 368 U. S. 347, 7 L. Ed. 2d 342, 82 S. Ct. 384 (1961), the Supreme Court held that where accounts receivable had been assigned to a finance company as security for a loan and thereafter a notice of United States tax liens was filed, the finance company had a superior lien. The Supreme Court in that case agreed with the Solicitor General's concession that the lien was completely choate even though, as the government contended before the Seventh Circuit Court of Appeals, the finance company did not have "possession" of the assigned accounts.

The "inchoate concept", as we see it, applies to the situation where the party asserting a lien or security interest must perform some positive act to perfect his lien and the levy is served before the positive act has been performed. In the instant case the Bank did not need to do anything to perfect its right of setoff. All it needed to do was to refuse Edmondson's (or the government's) demand that the Bank discharge the debt. No condition precedent to the existence of the right of setoff needed to be fulfilled. The right of the Bank was therefore fully choate in that Edmondson's debt to the Bank co-existed and exceeded the Bank's debt to Edmondson. It follows that the two debts cancelled on another at all times. The book-keeping entries made by the Bank were mechanical only and do not affect the substantive rights of the parties.

Analytically, a right or a chose in action is a legally enforceable claim. *People v. Main*, 75 Cal. App. 471, 483, 243 P. 2d 1078 (1925). We must therefore ask the question whether Edmondson at the time of the

levy had a legally enforceable claim against the Bank sufficient to compel the Bank to release to him funds equal to the deposit balance. The answer under the foregoing cases is obviously “no.”

If a Court were asked to determine as between Edmondson and the appellant whether the appellant was at the instant before the levy or at the time of the levy obligated to release funds to Edmondson, the judgment under California law would be in the Bank's favor. It follows that Edmondson had no legally enforceable claim and therefore had no “right to property” to which the lien could attach.

3. The Government Had No Enforceable Lien Upon the Checks Deposited by the Taxpayer or Upon the Proceeds Collected by the Bank by the Use of the Checks.

The credit of \$6,658.31 (with the exception of the \$240 credited to the savings account [Tr. 10]) shown on the books of the Bank in favor of the taxpayer represented credits for negotiable checks endorsed and delivered by the taxpayer to the Bank in July and August, 1959 [Tr. 22-24]. Indeed, \$5,478.94 was the balance of credits given by the Bank for checks deposited August 26, 1959, one day before the levy.

In the absence of actual notice of the United States tax liens (and appellant had none [Tr. 19]) the tax liens are invalid as far as the purchaser of a security is concerned. Section 6323(c) of Title 26 of the United States Code provides:

“Even though notice of a lien provided in Section 6321 has been filed in the manner prescribed in subsection (a) of this section, the lien shall not be valid with respect to a security, as defined in

paragraph (2) of this subsection, as against any mortgagee, pledgee or purchaser of such security for an adequate and full consideration in money or moneys worth, if at the time of such mortgage, pledge or purchase such mortgagee, pledgee or purchaser is without notice or knowledge of the existence of such lien.”

In paragraph 2 of subsection (c) “security” is defined as including any negotiable instrument or money. The Internal Revenue Service by Revenue Ruling 57-367 has recognized that banks could not function if they were compelled, as the District Judge suggested, to search the records of the County Recorder for possible United States tax liens prior to the acceptance of deposits. The Revenue Ruling provides:

“Assessment: Lien for taxes: Liability of bank: Property of depositor. — Banks, acting in the ordinary course of business with a depositor, without actual notice or knowledge (as distinguished from constructive notice) of a federal tax lien against the property or rights to property of the depositor, and in the absence of negligence or fraud, will not incur liability to the government in making payments of amounts on deposit to or on order of such depositor.”

The District Judge was apparently of the opinion that the checks deposited were not subject to any federal lien. Since this is so, neither are the proceeds of the checks the proper subject for a government lien. The checks became the property of the Bank upon deposit, and at the time of the credit a debt arose owing from the Bank to Edmondson which was more than offset by the debts then due from Edmondson to the Bank.

4. **The Decision in *Bank of Nevada v. United States* Is Distinguishable From the Instant Case and Is Inconsistent With Later Supreme Court Decisions.**

In the District Court the Government relied heavily upon the decision of this Court in *Bank of Nevada v. United States*, 251 F. 2d 820 (9th Cir. 1957). That case is distinguishable from the instant situation on its facts.

First, as has been demonstrated under California law, cross-demands are deemed to compensate each other. This rule is based upon Section 440 of the California Code of Civil Procedure and *Gonsalves v. Bank of America*, *supra*, 16 Cal. 2d 169. So far as we have been able to determine, there is no similar statute or case law in the State of Nevada.

Secondly, it is clear that this Court in *Bank of Nevada* based its decision on the proposition that the debt owing by the taxpayer to the Bank was not due at the time of the levy. In this case it is stipulated that all of the conditional sales contract balances, as well as the boat obligation and the unsecured note, were due at the time of the levy. In *Bank of Nevada*, the Court said (p. 826):

“It is clear that the only fact which gave the appellant the option of set off was the appellee’s demand and levy; but that demand and levy admittedly took place prior to the alleged exercise of the appellant’s option.”

In the instant case the Bank’s offset right existed prior to, at the time of and after the levy and no option is involved.

In *Bank of Nevada* the Court said (p. 824) :

“The Supreme Court has repeatedly and emphatically stated that federal tax liens and the provisions for collection are strictly *federal* and strictly *statutory*. Its provisions are unaffected by any alleged ‘general rule’ that a bank has a ‘general lien’ upon deposits.”

We respectfully submit that the foregoing premise is not in accord with the expressions of the Supreme Court found in *United States v. Bess*, *supra*, 357 U. S. 51, and *Aquilino v. United States*, *supra*, 361 U. S. 501, discussed in Section 1 of the argument in this brief. We submit that we are here involved first with the application of state law to determine the extent of the Bank’s obligation to the taxpayer. It is only after a decision can be reached that the taxpayer had a legally enforceable claim against the Bank that we reach any federal question.

We further submit that the decision in *Bank of Nevada* is inconsistent in principle with *Aquilino* and *Bess* decided by the Supreme Court subsequently and that it is also at variance with *In re Halprin*, *supra*, 280 F. 2d 407, and the other cases discussed in Section 1 of this Argument. As we read those cases the fundamental approach is whether or not the taxpayer could force his debtor to pay the money over to him at the time of the levy, and where the Court finds that the taxpayer could not compel such a payment there is nothing to which the government’s lien can attach. This ruling is based upon the concept that the government’s

rights against the debtor of the taxpayer can rise no higher than the taxpayer's rights. In the instant case, the Bank's refusal to pay Edmondson could take place any time prior to actual payment by the Bank. To illustrate, if Edmondson had walked to the window of the Bank at the same instant that the Government Revenue Agent presented the notice of levy, the Bank could have refused to honor Edmondson's demand and also simultaneously refused to honor the government's levy unless the government's rights rose higher than those of Edmondson, and the Supreme Court has said that they do not. *United States v. Bess, supra.*

In *Bank of Nevada v. United States* the Court relied in part upon the District Court decision in *United State v. Graham*, 96 Fed. Supp. 318-321, affirmed *per curiam sub nom.*, *State of California v. United States*, 195 F. 2d 530 (9th Cir. 1952). We believe that this case also is inconsistent with the opinions of the Supreme Court in *United States v. Bess* and *Aquilino* and cases in other circuits cited in Section 1 of this brief. It is further to be noted that the reasoning of the District Court in *Graham* is not applicable to the instant situation because of the special exception with respect to negotiable instruments and bank deposits found in Title 26 United States Code, Section 6323, as implemented by Revenue Ruling 57-367, I. R. B. 1957 32, 22, quoted in the preceding section of this brief.

Conclusion.

State law controls the decision as to the existence of rights to property subject to a federal tax lien. Under California law the taxpayer had no right, legally enforceable, to compel the payment of the Bank's obligation to him because of the offsetting debt owed by him to the Bank. The District Court was clearly wrong in granting the government's motion for summary judgment and in refusing to grant the Bank's motion.

Respectfully submitted,

SAMUEL B. STEWART,
ROBERT H. FABIAN,
ALFRED T. TWIGG,

Attorneys for Appellant.

Certificate.

I certify that, in connection with the preparation of this brief, I have examined Rules 18 and 19 of the United States Court of Appeals for the Ninth Circuit, and that, in my opinion, the foregoing brief is in full compliance with those rules.

ROBERT H. FABIAN





TOPICAL INDEX

| | PAGE |
|---|------|
| Origin of the appeal..... | 1 |
| Jurisdictional statement..... | 2 |
| Statement of facts..... | 2 |
| Specifications of error..... | 4 |
| Argument | 5 |
| A. The Bankruptcy Court has jurisdiction to adjudicate the present controversy..... | 5 |
| B. If the bankruptcy trustee occupied the premises to the exclusion of the landlord, he may be totally liable for post bankruptcy rent..... | 8 |
| Conclusion | 9 |

TABLE OF AUTHORITIES CITED

| CASES | PAGE |
|---|------|
| American Fidelity Corp., Ltd., In the Matter of, 28 Fed. Supp. 462..... | 5 |
| American Gramophone Co. v. Leeds and Kaplan Co., 174 Fed. 158..... | 7 |
| Boston Terminal Co. v. Mutual Savings Bank Group, 127 F. 2d 707..... | 5 |
| City of Long Beach v. Metcalf, 103 F. 2d 483..... | 5 |
| Freeman, Matter of, 49 Fed. Supp. 163..... | 7 |
| Governer Clinton Co. v. Knott, 120 F. 2d 149..... | 7 |
| Magnolia Petroleum Co. v. Thompson, 106 F. 2d 217..... | 5 |
| San Clemente Electric Supply, In re, 101 Fed. Supp. 252.... | 5, 7 |
| Watters v. Dunn, 56 F. 2d 223..... | 5 |
| Westall v. Avery, 171 Fed. 626..... | 5 |

STATUTES

| | |
|--|---|
| Bankruptcy Act, Sec. 2..... | 5 |
| United States Code, Title 28, Sec. 1291..... | 2 |

TEXTBOOK

| | |
|--|---|
| 2 Collier on Bankruptcy (14th Ed.), p. 449 et seq..... | 5 |
|--|---|

No. 18143

IN THE

United States Court of Appeals

FOR THE NINTH CIRCUIT

LAMA COMPANY, a corporation,

Appellant,

vs.

UNION BANK, *et al.*,

Appellee.

**Opening Brief of Appellant Lama Company,
a Corporation.**

Origin of the Appeal.

The matter commenced as a part of the bankruptcy proceedings involving one Charles Crawl, Bankrupt, in Bankruptcy No. 126319-T in the United States District Court, Southern District of California, Central Division, by the filing of a petition for determination of rental due subsequent to bankruptcy on December 29, 1961. [Clk. Tr. pp. 2-9.] An Order To Show Cause was issued by the Referee on the same date. [Clk. Tr. p. 10.] Subsequently, a response was filed on behalf of Union Bank. [Clk Tr. p. 11] and on behalf of the Trustee in Bankruptcy. [Clk. Tr. p. 15.] After hearing before the Referee in Bankruptcy on January 11, 1962, the Referee made Findings of Fact, Conclusion of Law and Order re Post Bankruptcy Rent. [See Clk. Tr. pp. 39-43.] This was filed on March 15, 1962, and thereafter the Appellant filed a Petition for Review with the

District Court. [See Clk. Tr. p. 44.] On May 22, 1962, the United States District Court filed and entered its Order affirming the decision of the Referee in the premises. [See Clk. Tr. pp. 47-48.] On June 20, 1962, the Appellant and Petitioner Lama Company, a corporation, filed its Notice of Appeal [Clk. Tr. p. 50.]

Jurisdictional Statement.

The original jurisdiction of the District Court was under the *National Bankruptcy Act*. The jurisdiction of this Court on this appeal would lie under Section 1291, Title 28, *United States Code*.

Statement of Facts.

The statement of the case as presented by the Referee in his Certificate on Review to the District Court is essentially accurate. The Court's specific attention is called to his summary contained between line 10, p. 35 and line 30, p. 36, of the Clerk's Transcript in this cause.

For ease of presentation, the statement of the case is basically quoted upon the Referee's Certificate and the reference is there found. Prior to bankruptcy, the bankrupt had occupied, under a lease for his business purposes, certain premises owned by Lama Co. and located at 11659-61 and 11665-67 McBean Drive, El Monte, California. The bankrupt had been engaged in the business of a plastic sheet manufacturer. The lease provided for a monthly rental of \$743.00, plus an additional monthly charge of \$16.00 for insurance premiums. Upon taking possession of the premises and inventorying the bankrupt's assets located thereon, the Trustee learned that approximately two-thirds of the

machinery and equipment located therein was subject to encumbrances held by the Union Bank. This fact was not disputed at the hearing held before the undersigned Referee in Bankruptcy to determine the amount of the landlord-Lama Co.'s claim for administrative rent.

The amount of the Union Bank's encumbrance was such that the Trustee determined that the bankrupt estate had no equity in the heavy machinery and equipment subject to the encumbrance. Prior to bankruptcy, the bankrupt with the agreement of the Union Bank, had arranged with an auctioneer to sell all of the machinery and equipment and other assets, including both that subject to the encumbrance and that which was free and clear. When the Trustee (then the Receiver) originally took possession of the premises, he determined to go forward jointly with the Union Bank with the previously agreed upon auction.

As found by the Referee in bankruptcy [Find. of Fact IV, Clk. Tr. p. 40], after July 30, 1961, the Trustee in bankruptcy determined to abandon any interest in the conditional buyer's and lessee's rights in the machinery and equipment subject to the encumbrance held by the respondent Union Bank. It was undisputed at the hearing that the Trustee's liability for administrative rent commenced on June 1, 1961, and terminated on August 24, 1961, at which time the premises were returned to the landlord Lama Co., with the joint auction sale conducted by the Trustee and the Union Bank. The total rent called for by the lease for said period would have been the sum of \$2,105.28. Throughout the period from the onset of bankruptcy and August 24, 1961, the landlord and pe-

titioner Lama Co. was excluded from the premises by signs and by securing devices set up by the Trustee. The Referee reasoned that in as much as the articles of personalty which constituted the assets of the bankrupt estate amounted to approximately one-third (both in dollar value and in physical space occupied) of the total of the personalty located on the premises, only one-third of the total rent for the period in question would be ascribable to the Trustee. This amount, together with insurance premiums totalling \$44.24 and the sum of \$60.00 (being the cost of repairing certain damage to the premises occasioned by the Trustee's occupancy), or a total of \$806.00, was fixed as the Trustee's liability for administrative rent. The Referee did make the finding that Union Bank had received value in that the subject premises were utilized to store machinery and equipment on its behalf, but no summary jurisdiction, in the view of the Referee, existed as to the Union Bank to enable the Court to make an order of payment respecting the same. [See Clk. Tr. p. 41, lines 9-23.]

Specifications of Error.

1. The District Court erred in finding a lack of jurisdiction to adjudicate the present controversy.
2. The District Court erred, in the alternative, in failing to find that the bankruptcy Trustee was totally liable for post bankruptcy rent, and should seek contribution from Union Bank if necessary.

ARGUMENT.

A. The Bankruptcy Court Has Jurisdiction to Adjudicate the Present Controversy.

It is clear that the Bankruptcy Act confers jurisdiction in both law and equity in connection with controversies arising in bankruptcy. See Section 2 of the *Bankruptcy Act*; *Boston Terminal Co. v. Mutual Savings Bank Group*, 127 F. 2d 707; cf. *Westall v. Avery*, 171 Fed. 626. The Bankruptcy Court has power in a summary proceedings to adjudicate title to property in the actual or constructive possession of the trustee. *Magnolia Petroleum Co. v. Thompson*, 106 F. 2d 217; *In the matter of American Fidelity Corp., Ltd.*, 28 Fed. Supp. 462 (S. D. Cal.) It can adjudicate lien or security status. *In re San Clemente Electric Supply*, 101 Fed. Supp. 252 (S. D. Cal.). It has long been clear that it may exercise jurisdiction over matters pertaining to bankruptcy administration. See Vol. 2, p. 449 *et seq.*, *Collier on Bankruptcy* (14th Edit.), *City of Long Beach v. Metcalf*, 103 F. 2d 483.

The question here is simply refined to the obvious query: Does the Bankruptcy Court have the power, and indeed the duty to adjudicate post bankruptcy rent, as to the parties involved in the same where property occupying the landlord's premises is in the custody of the trustee? Starting with the concept of *Watters v. Dunn*, 56 F. 2d 223 (S. D. Cal.), the answer seems obviously affirmative. A landlord's rights are not lost or held in a vacuum because a bankruptcy petition is filed. It is implicit that the user of premises has an implied duty to pay for the same unless the owner agrees that the premises are furnished gratuitously.

Post bankruptcy rental is one of the features and may be one of the “controversies” concerned in post bankruptcy proceedings. Both as a matter of logic and of law, it would seem that the Bankruptcy Court has the right and the duty to fully adjudicate.

Under the factual circumstances posed, the bankruptcy trustee would have the duty to pay rent to the landlord for utilization of premises occupied by or on behalf of the trustee, unless a coordinate duty of obligation arose in someone else or some other party to the proceedings. This was the purpose of the petition of the landlord, *viz.* to determine rental allocation. See Document Number 1 certified by the referee in his certificate. [Clk. Tr. pp. 2-9.] As will be observed in the documents certified as 3 and 4, responses were filed, admitting and creating issues on certain of the factual situations set up in the petition. The Referee determined from the testimony at the hearing that although the trustee had control and domination of the landlord’s premises throughout the period in question, [see Find. of Fact III and IV], two-thirds of the chattels held therein were abandoned to the Union Bank and one-third were accepted by the trustee in bankruptcy. Accordingly, the Referee reasoned the trustee should be liable for only one-third of the rent. To suddenly refuse jurisdiction to require rental payment from the respondent Union Bank under such circumstances is tantamount to instructing petitioner to institute suit in the State Court against the respondent trustee and

respondent Union Bank. (There being no written instrument to go by, obviously petitioner would be obliged to take the cautious course of suing both parties involved in the utilization of the premises. Otherwise, entirely dissimilar decisions might be reached by the two different courts.) The philosophy of the Bankruptcy Act and its sections regarding administration is to centralize and simplify legal proceedings relating to bankruptcy. The implication of denial of jurisdiction in the present instance would necessarily mean the proliferation of litigation. Although legal difficulty is not a sufficient reason in itself, nevertheless increasing litigation to various courts runs contrary to the legal and judicial trend of the law and the theory of the *Bankruptcy Act*. It is sometimes said that once the bankruptcy petition has been filed, the bankruptcy court's jurisdiction is paramount and no other court may by order or decree assume this jurisdiction. In fact, restraining orders may be issued to enjoin state court action. See, generally, *American Gramophone Co. v. Leeds and Kaplan Co.*, 174 Fed. 158; *in re San Clemente Electric Supply*, 101 Fed. Supp. 252 (S. D. Cal.). Certainly the disaffirmance of a lease is well within the bankruptcy court jurisdiction. *Matter of Freeman*, 49 Fed. Supp. 163. The Bankruptcy Act and the court acting thereunder follows the theory that summary jurisdiction exists to protect the bankruptcy estate from imposition. See *Governor Clinton Co. v. Knott*, 120 F. 2d 149. Here the Union Bank will have benefited

for storage purposes from the period commencing with the filing of the bankruptcy petition to August 24, 1961. If the State Court adjudicates that the trustee by reason of mere fact of possession of the premises is totally liable, obviously the bankruptcy estate itself suffers by the Union Bank's imposition. The alternative is that the landlord must suffer with the loss of two-thirds of the applicable rent. The equitable conscience of the court should be disturbed by such travesty of conscience. It is respectfully submitted that technicalities and legal niceties should not obscure the duty of the Bankruptcy Court to fairly adjudicate the controversies arising directly out of and a part of the bankruptcy administration.

B. If the Bankruptcy Trustee Occupied the Premises to the Exclusion of the Landlord, He May Be Totally Liable for Post Bankruptcy Rent.

This argument, as the court will realize, is alternative to the first argument point. It is undisputed that the trustee occupied and held the premises adversely to the landlord up to the date of August 24, 1961 when the sale of chattels was held. This possession was open, notorious and adverse to the landlord's rights. In fact, an award was made to the landlord for damages inflicted on the premises by the trustee or his agents. Under the ordinary principles of law, it could be argued that if a person occupied premises, he would be fully liable to the owner thereof, regardless of whose property was stored within the premises. An argument

of some surface cogency might be made that the trustee should be liable in the bankruptcy proceedings to the landlord for the full amount of the rent, to wit \$2,105.28, but would have the right to sue in the state courts for reimbursement by the Union Bank. This, of course, would achieve fairness to all parties and the court may be so minded to reverse the order below and so instruct the referee. The disadvantage to such a procedure is that it also requires the proliferation of litigation and the utilization of the services of the general jurisdiction state court for a controversy which seems completely settled in bankruptcy proceedings.

Conclusion.

It is respectfully submitted that the order of the referee below should be reversed, and that either the referee below required to make an order assuming jurisdiction over the respondent Union Bank and ordering payment for the remaining balance of the rent to the petitioner landlord, or alternatively ordering payment to the petitioner landlord by the trustee and instructing the trustee to institute suit in the state courts for reimbursement from the respondent Union Bank.

Respectfully submitted,

JULIUS A. LEETHAM,

*Attorney for Appellant, and
Petitioner, Lama Company.*

Certification.

I certify that, in connection with the preparation of this brief, I have examined Rules 18 and 19 of the United States Court of Appeals for the Ninth Circuit, and that, in my opinion, the foregoing brief is in full compliance with those rules.

JULIUS A. LEETHAM,
Attorney for Appellant, Lama Co.

No. 18143

IN THE

United States Court of Appeals

FOR THE NINTH CIRCUIT

LAMA COMPANY, a corporation,

Appellant,

vs.

UNION BANK, *et al.*,

Appellees.

REPLY BRIEF OF APPELLEE UNION BANK.

LOEB AND LOEB,
ALFRED I. ROTHMAN,
ROBERT A. HOLTZMAN,
523 West Sixth Street,
Los Angeles 14, California,
Attorneys for Appellee Union Bank.

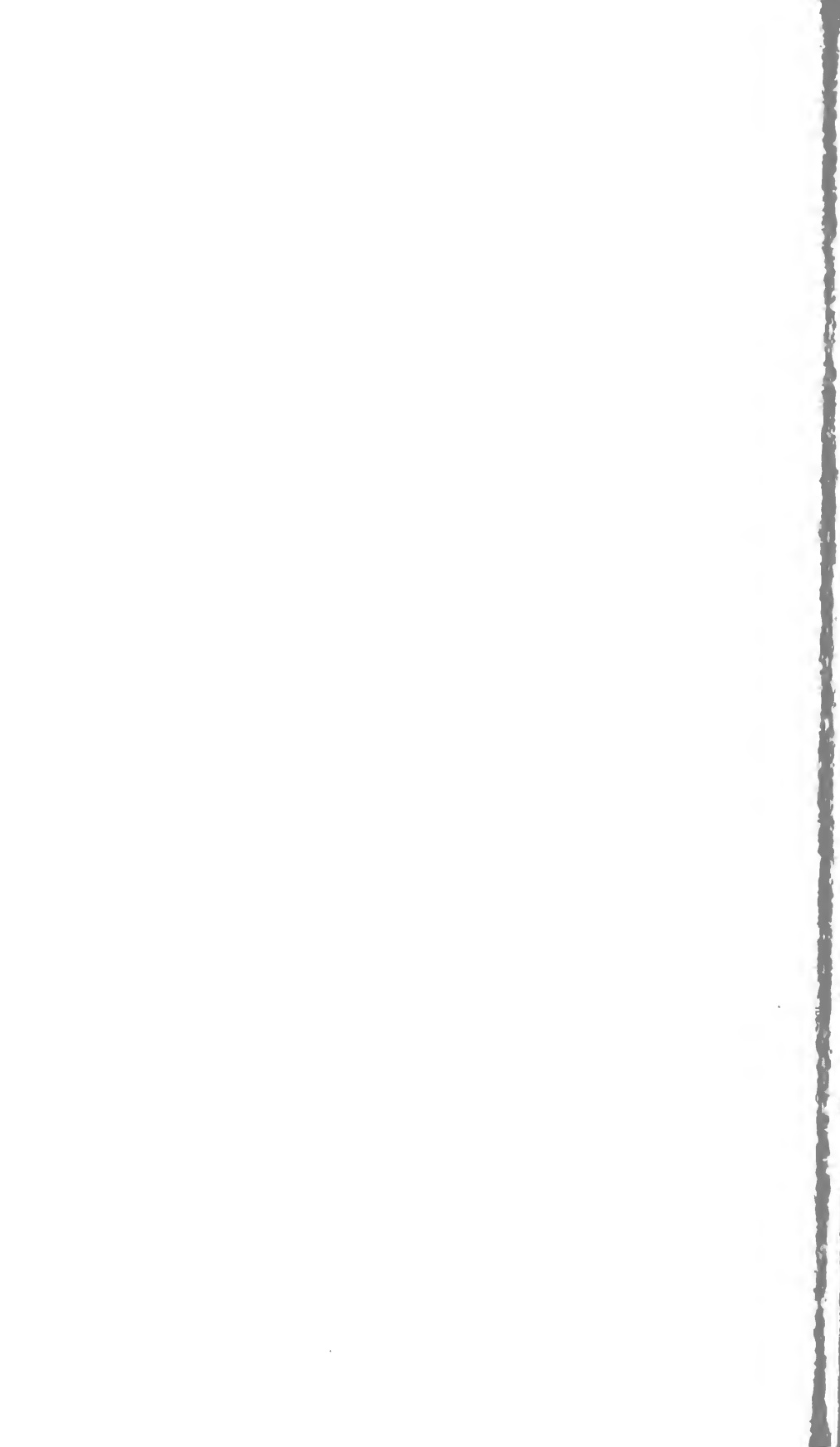

TOPICAL INDEX

| | PAGE |
|--|------|
| Jurisdiction | 1 |
| Introductory statement | 2 |
| Argument | 4 |
| I. | |
| The trustee's liability for administrative rent is determined, not by the terms of the bankrupt's former lease, but by the fair and reasonable value of the premises occupied to the bankrupt estate | 4 |
| II. | |
| The existence of a duty on the part of the trustee to pay rent does not create jurisdiction in the bankruptcy court to order a secured creditor to pay additional rent..... | 5 |
| III. | |
| Appellant's arguments from convenience are without merit.. | 8 |
| Conclusion | 10 |

TABLE OF AUTHORITIES CITED

| CASES | PAGE |
|---|------|
| Central State Corp. v. Luther, 215 F. 2d 38..... | 8 |
| Chakos, In re, 24 F. 2d 482..... | 8 |
| Evarts v. Eloy Gin Corp., 204 F. 2d 712, cert. den. 346 U. S. 876, 98 L. Ed. 384, 74 S. Ct. 129..... | 5, 7 |
| Hotel Martin of Utica, In re, 94 F. 2d 643..... | 7 |
| Hudson v. Wylie, 242 F. 2d 435..... | 2 |
| Lubliner & Trinz Theatres, In re, 100 F. 2d 646..... | 7 |
| Kaplan v. Guttman, 217 F. 2d 481..... | 7 |
| Production Aids, Inc., In re, 193 Fed. Supp. 180..... | 8 |
| Third Avenue Transit Corporation, In re, 153 Fed. Supp. 706 | 8 |

RULES

| | |
|--|---|
| Federal Rules of Civil Procedure, Rule 52..... | 2 |
|--|---|

STATUTES

| | |
|---|---|
| Bankruptcy Act, Sec. 24..... | 2 |
| Bankruptcy Act, Sec. 62(a)(1)..... | 4 |
| General Order No. 47..... | 2 |
| United States Code, Title 11, Sec. 47..... | 2 |
| United States Code, Title 11, Sec. 102(a)(1)..... | 4 |

TEXTBOOKS

| | |
|---|---|
| 3 Collier on Bankruptcy (14th Ed.), Par. 62.14[2], p. 1511 | 4 |
| 3 Collier on Bankruptcy (14th Ed.), Par. 62.14[2], pp. 1512-1514 | 4 |
| 8 Collier on Bankruptcy (14th Ed.), Par. 3.02, note 2, p. 124 | 8 |

No. 18143

IN THE

United States Court of Appeals

FOR THE NINTH CIRCUIT

LAMA COMPANY, a corporation,

Appellant,

vs.

UNION BANK, *et al.*,

Appellees.

REPLY BRIEF OF APPELLEE UNION BANK.

By the within appeal, Lama Company attempts to reopen questions concerning the jurisdiction of the District Court, sitting as a court of Bankruptcy, that are so well settled as to admit of no substantial dispute. It would appear that Appellant's argument, based solely upon convenience, is inappropriate in this Court (or for that matter, in any court), and, moreover, that if followed it would give rise to a dangerous and unwise precedent.

Jurisdiction.

Although summary jurisdiction was *invoked* under the Bankruptcy Act, the Referee found that he had no summary jurisdiction over Union Bank (which had appeared specially in order to raise the question of jurisdiction) and dismissed the petition, insofar as Union

Bank was concerned, for lack of jurisdiction [Tr. pp. 11, 39, 41, 42, 43, see also pp. 34, 37]. Jurisdiction to review this decision exists by virtue of Section 24 of the Bankruptcy Act, 11 U. S. C. Section 47.

Introductory Statement.

Having appeared only specially, and having been advised by the Referee that its objection to the exercise of summary jurisdiction over it was well taken, Union Bank could not adduce evidence bearing upon the merits of the controversy without running the risk of waiving its objection to the exercise of summary jurisdiction. Thus, the only evidence before the Referee was that presented by the Appellant and the Trustee; Union Bank tendered no evidence, called no witnesses, and did not cross-examine.

No transcript of the proceedings before the Referee having been certified to this Court, all findings must be deemed to be supported by the evidence.¹

Insofar as the appeal with respect to Appellee Union Bank is concerned, appellant asks this court to hold, in substance, that the Referee had summary *in personam* jurisdiction over Union Bank, although it was not otherwise, in any way, party to the bankruptcy proceedings,

¹The District Court was required to accept the Referee's findings of fact unless clearly erroneous. General Order No. 47, and the scope of appellate review is governed by the same standard, Rule 52, F. R. C. P. See *Hudson v. Wylie*, 242 F. 2d 435, 450 (9 Cir., 1957).

where it had duly objected to the exercise of summary jurisdiction, and where the obligation sought to be adjudicated was the claim of Appellant, a post-bankruptcy creditor seeking to recover rent from the Trustee, that Union Bank should also pay rent to it because it had a security interest in some of the bankrupt's equipment, which equipment was ultimately abandoned by the trustee. Although it is clear that the Referee could properly adjudicate Appellant's claim against the Trustee, we shall demonstrate that it does not follow, as Appellant claims, that he had the further power to adjudicate Appellant's claim against the Bank, whatever the subject-matter relationship of the two claims.

ARGUMENT.

I.

The Trustee's Liability for Administrative Rent Is Determined, Not by the Terms of the Bankrupt's Former Lease, but by the Fair and Reasonable Value of the Premises Occupied to the Bankrupt Estate.

It is well settled that the trustee may continue to occupy leased premises formerly occupied by the bankrupt, that it is obligated to pay rent therefor, and that if it does not pay the lessor may properly present a claim for administrative rent and petition the Bankruptcy Court for allowance of the claim.

Bankruptcy Act, Sec. 62(a)(1), 11 U. S. C. Sec. 102(a)(1);

3 Collier on Bankruptcy, 14th Ed., Par. 62.14[2], p. 1511.

It is equally well settled that where the Trustee has elected to reject the bankrupt's lease and surrender the leased premises, its liability for post-bankruptcy rent prior to the surrender is not measured by the former lease (which ceases to exist for all purposes) but rather by the value of the use of the premises reasonably necessary for the preservation of the bankrupt estate.

3 Collier on Bankruptcy, 14th Ed., Par. 62.14[2], pp. 1512-1514.

The Referee found the fair and reasonable value of the space necessarily occupied by the Trustee to have been \$701.76 and awarded this sum, together with other sums totaling \$104.21, to Appellant [Tr. pp. 41-

42, 43]. Union Bank is not in any way concerned with this determination and expresses no opinion with regard to it except to concede that the Referee had jurisdiction to make it. No evidence being before this Court, apart from the findings, the amount, of course, cannot be claimed now either to be excessive or inadequate.

II.

The Existence of a Duty on the Part of the Trustee to Pay Rent Does Not Create Jurisdiction in the Bankruptcy Court to Order a Secured Creditor to Pay Additional Rent.

Appellant's case, in sum, proceeds on the assumption that the power of the Court to order the Trustee to pay rent gives rise, by implication, to a further power to charge a stranger to the bankruptcy proceedings with some portion of that rent. Petitioner cites no authority for this startling proposition, which is inconsistent with basic concepts of bankruptcy jurisdiction, and directly contrary to the authorities discussed hereinbelow.

As a general proposition, a court of bankruptcy does not have summary jurisdiction to enter an *in personam* judgment over an adverse party who has made timely objection to the exercise of such jurisdiction. More particularly, except where title to property actually or constructively in the possession of the bankrupt is at issue, the rule is that a court of bankruptcy lacks jurisdiction over a controversy between third persons.

The decision of this Court in *Evarts v. Eloy Gin Corp.*, 204 F. 2d 712 (9th Cir., 1953), cert. den. 346 U. S. 876, 98 L. Ed. 384, 74 S. Ct. 129 (1953) is

squarely in point. In this case, one Evarts, a specialist in the field of liquidating the assets of corporations in financial difficulty and procuring new funds to aid ailing businesses, claimed to have performed services for the benefit of three corporations in the process of reorganization under Chapter XI, at the instance of the receiver, the president of the three corporations, and an interested purchaser. He filed a claim for his compensation in the arrangements proceedings, seeking an order for payment against the receiver and the president of the corporations personally, and a declaration that the claim be declared an obligation of the prospective purchaser. The referee, on his own motion, dismissed the petition as to the president and the prospective purchaser for lack of jurisdiction, retained jurisdiction as to the receiver, and denied the claim as to him on the merits. The district court approved and confirmed the orders of the referee, and, on appeal, this Court affirmed. After discussing in detail the limited and specific nature of the jurisdiction of the Bankruptcy Court, this Court concluded:

“The Bankruptcy Court has no jurisdiction in controversies between third parties not involving the debtor or his property * * *. It is clear that Pretzer (the president), as an individual, was a third party to the debtor proceedings; and as to any claim of petitioner’s against him it is purely personal and cannot involve the property while it was held by the Receiver. The Bankruptcy Court’s order of dismissal as to Pretzer was proper.

“Landers (the purchaser) was the principal creditor of the Debtor Corporations at the time of appellant’s petition, having obtained an assignment

of most of the claims against the Debtor Corporations outside of the Arrangement Proceedings. As a creditor of the Debtor Corporations he was subject to the Bankruptcy Court's jurisdiction in his dealings with the debtors; but he was not subject to the Bankruptcy Court's jurisdiction in his dealings with third parties, in which category *Evarts* falls. Therefore, the Bankruptcy Court's jurisdiction over appellant's claim against Landers was properly declined." 204 F. 2d at 717.

The *Evarts* case is completely dispositive of this appeal. Landers, like Union Bank a creditor of the debtors, had subjected himself to the jurisdiction of the Bankruptcy Court as to his claims; notwithstanding, no jurisdiction existed as to the controversy between him and *Evarts*. *A fortiori*, there can be no jurisdiction as to Union Bank, which has never presented a creditor's claim or otherwise subjected itself to summary jurisdiction.

The rule of law articulated in *Evarts* has been consistently followed both by this Court and by other federal courts.

See, for example:

Kaplan v. Guttman, 217 F. 2d 481, 485 (9th Cir., 1954);

In re Lubliner & Trinz Theatres, 100 F. 2d 646 (7th Cir., 1938);

In re Hotel Martin of Utica, 94 F. 2d 643 (7th Cir., 1938);

In re Third Avenue Transit Corporation, 153
Fed. Supp. 706 (S. D. N. Y., 1957);
8 Collier on Bankruptcy, 14th Ed., Par. 3.02,
Note 2 at p. 124.

See also:

Central State Corp. v. Luther, 215 F. 2d 38
(10th Cir., 1954);

In re Production Aids, Inc., 193 Fed. Supp. 180
(S. D. Ia., 1961).

Indeed it has been stated that even if the parties had consented, they could not by so doing invest the Bankruptcy Court with jurisdiction to determine a controversy such as this.

In re Chakos, 24 F. 2d 482, 485 (7th Cir., 1928).

III.

Appellant's Arguments From Convenience Are Without Merit.

In its argument from convenience, Appellant assumes, first, that "the user of premises has an implied duty to pay for the same, unless the owner agrees that the premises are furnished gratuitously" (App. Op. Br. p. 5), and second, that Union Bank "used" Appellant's premises under circumstances sufficient to give rise to this "implied duty." These assumptions are baseless, both legally and factually.

In the first place, no contractual or quasi-contractual obligation to pay is pleaded or appears to be claimed; Appellant proceeds on the theory that the occupancy of the premises, without more, gives rise to the implied duty referred to. But such a duty would

exist only if the occupancy constituted a trespass. In this instance, while intent need not be shown, it would be incumbent upon Appellant to plead and show, at the minimum, wilful or voluntary occupancy on the part of Union Bank. This has not been done.

It may not be assumed on this record that Union Bank's occupancy of the premises was voluntary. The findings indicate the contrary to be true. The Trustee (then the Receiver) secured and blocked off the premises containing the equipment in which the Bank held an interest, taking possession of the equipment, and as effectively barring the Bank from it as Appellant was barred from its premises [Tr. p. 40]. The Trustee ultimately abandoned the equipment at some time after July 30, 1961 [Tr. p. 40]. It must be remembered that Union Bank introduced no evidence and thus *its* evidence concerning its dealings with the Receiver and the Appellant was not before the Referee. But even on the limited record available, the absence of wilfulness is manifest.

Appellant's argument from convenience proceeds on the assumption that Union Bank *must* be liable to it and that a suit in state court will only delay the ultimate result. As indicated, this assumption finds no support, either in law, or in the findings of the Referee. In fact, in the absence of jurisdiction over Union Bank, the referee should not even have found, as he purported to do, that Union Bank received value.²

²In view of the judgment of dismissal and consequent lack of prejudice, Union Bank did not appeal from this finding.

Appellant suggests that the refusal of the Court below to exercise jurisdiction over Union Bank was tantamount to an instruction for it to institute state court proceedings against both the Trustee and Union Bank (App. Op. Br. p. 6). Surely Appellant does not mean this; it already has a judgment against the Trustee. While the denial of summary jurisdiction in any case leaves a plenary suit as the only alternative, it is in no sense an invitation to file such a suit, particularly where all proper relief has been granted. Appellant really means that in the absence of an agreement to pay rent it may have difficulty in proving a case in state court; it prefers the summary, relatively informal procedure of the bankruptcy court to the more time-consuming procedure of a state court. The fact that Appellant finds it more convenient and perhaps tactically advantageous to proceed in a single suit, in the bankruptcy court, is no reason, however, to deny Union Bank its right to a plenary trial if it deems it desirable to exercise that right.

Conclusion.

For each and all of the foregoing reasons the order of The Honorable William M. Byrne, United States District Judge, dated May 22, 1962, affirming the order of the Referee in Bankruptcy, should be affirmed.

Respectfully submitted,

LOEB AND LOEB,
ALFRED I. ROTHMAN,
ROBERT A. HOLTZMAN,

Attorneys for Appellee Union Bank.

Certificate.

I certify that, in connection with the preparation of this brief I have examined Rules 18 and 19 of the United States Court of Appeals for the Ninth Circuit, and that, in my opinion, the foregoing brief is in full compliance with those Rules.

ROBERT A. HOLTZMAN.



No. 18143

IN THE

United States Court of Appeals

FOR THE NINTH CIRCUIT

LAMA COMPANY, a corporation,

Appellant,

vs.

UNION BANK, *et al.*,

Appellees.

Brief of Appellee—William N. Bowie, Jr., Trustee
in Bankruptcy of the Estate of Charles A.
Crowl.

FILED

1931

QUITTNER, STUTMAN & TREISTER,

639 South Spring Street,
Los Angeles 14, California,

FRANK H. SCHWID, CLERK

*Attorneys for Appellee-Trustee
in Bankruptcy.*

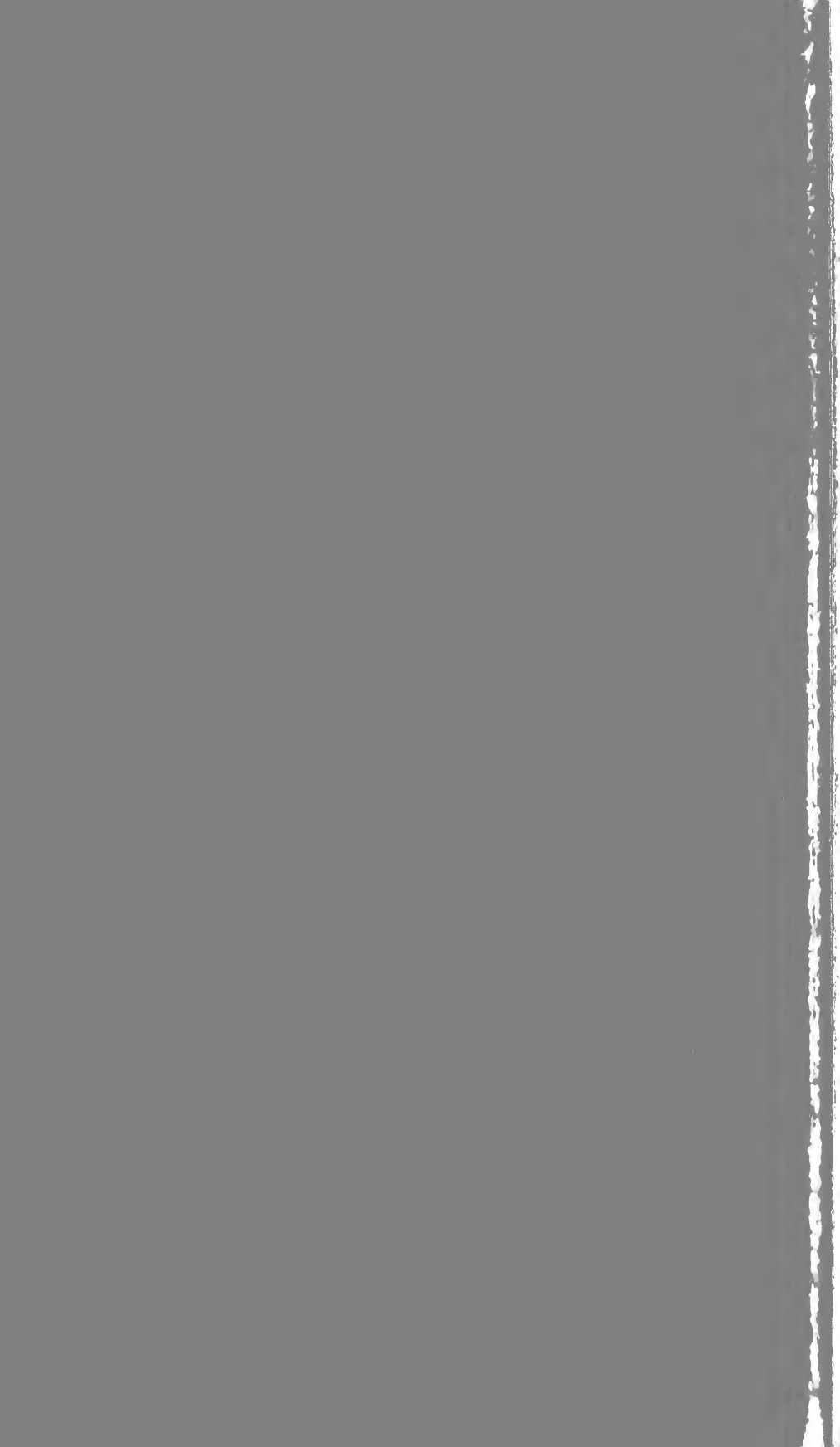

TOPICAL INDEX

| | PAGE |
|--|------|
| Jurisdiction | 1 |
| Questions presented..... | 1 |
| Argument | 2 |
| 1. There was no error in the referee's determination of the amount of administrative rent for which appellee- trustee in bankruptcy was liable..... | 2 |
| 2. The referee correctly concluded that there was no summary jurisdiction to award judgment in favor of appellant and against appellee—Union Bank..... | 4 |
| Conclusion | 4 |

TABLE OF AUTHORITIES CITED

| CASES | | PAGE |
|--|--|------|
| Hudson v. Wylie, 242 F. 2d 435..... | | 3 |
| MISCELLANEOUS | | |
| General Order in Bankruptcy No. 47..... | | 3 |
| STATUTES | | |
| Bankruptcy Act, Sec. 24..... | | 1 |
| United States Code, Title 11, Sec. 47..... | | 1 |
| TEXTBOOKS | | |
| 2 Collier on Bankruptcy, pp. 467 et seq..... | | 4 |

No. 18143

IN THE

United States Court of Appeals

FOR THE NINTH CIRCUIT

LAMA COMPANY, a corporation,

Appellant,

vs.

UNION BANK, *et al.*,

Appellees.

Brief of Appellee—William N. Bowie, Jr., Trustee
in Bankruptcy of the Estate of Charles A.
Crowl.

Jurisdiction.

The Court has jurisdiction of this appeal under Section 24 of the Bankruptcy Act, 11 U. S. C. Sec. 47.

Questions Presented.

1. Did the Referee in Bankruptcy err in finding that the reasonable rental value of appellant's premises for which appellee-Trustee in Bankruptcy was liable was the sum of \$806?

2. Did the Referee in Bankruptcy err in concluding that the bankruptcy court lacked summary jurisdiction to award an *in personam* judgment in favor of appellant and against appellee-Union Bank for the reasonable rental value of appellant's premises occupied by the Bank?

ARGUMENT.

1. **There Was No Error in the Referee's Determination of the Amount of Administrative Rent for Which Appellee-Trustee in Bankruptcy Was Liable.**

Appellee-Union Bank was the holder of an encumbrance on a major part of the bankrupt's machinery and equipment. Prior to bankruptcy, when it became apparent that the business could not continue, the Bank and the bankrupt had arranged for a joint auction of the encumbered and the unencumbered property. Bankruptcy occurred before the sale. Appellee-Trustee in Bankruptcy, determining that there was no equity in the machinery and equipment over the encumbrance, abandoned these assets and assented to the joint auction theretofore arranged.

The bankrupt's premises were vacated and returned to appellant-landlord on August 24, 1961 at the conclusion of the liquidation sale. It is common ground that the Trustee is liable to appellant only for the reasonable rental value of the premises occupied by the estate during the period June 1, 1961 to August 24, 1961.

The Referee in Bankruptcy found in effect that each of the appellees occupied a portion of the subject premises solely for storage purposes during that period. Since the property of the Bank located upon the premises amounted to approximately two-thirds in value and in physical bulk of the total of the personal

property stored there, the Referee determined that the reasonable value of the premises occupied by the Trustee was one-third of the rental reserved in the lease. To this figure were added certain minor expenses which are not now disputed, resulting in a finding that the Trustee's administrative rent liability was the sum of \$806. On review, the District Judge affirmed.

A determination by a Referee in Bankruptcy of reasonable rental value clearly is a finding of fact. As such, it is not subject to reversal unless clearly erroneous, particularly where the finding is approved on review by the District Judge.

General Order in Bankruptcy No. 47;

See, *e.g.*, *Hudson v. Wylie*, 242 F. 2d 435, 450 (C. A. 9, 1957).

On the present appeal, appellant is faced with a further difficulty arising from its decision not to bring to this Court the transcript of the proceedings before the Referee in Bankruptcy on January 11, 1962, when the matter of administrative rent was tried. This gap in the record alone should make it impossible for a reviewing court to conclude that a finding of fact was clearly erroneous.

But regardless of the foregoing, appellee-Trustee submits that the record here amply supports the ruling below, and that the Order appealed from is correct beyond doubt.

2. **The Referee Correctly Concluded That There Was No Summary Jurisdiction to Award Judgment in Favor of Appellant and Against Appellee—Union Bank.**

Appellee-Trustee, of course, is not financially involved with the question of whether the Referee should have granted judgment against appellee-Union Bank for the value of the portion of the premises which it occupied. It should be pointed out, however, that the settled rules of summary jurisdiction would preclude such an award where, as here, a timely objection was asserted. Insofar as the Bank is concerned, appellant's effort is to obtain an *in personam* judgment for money due. It is not an *in rem* proceeding to establish rights in property in the bankruptcy court's actual or constructive possession, nor has there been consent or submission to jurisdiction by the adverse party. Thus, there is no possible basis for summary jurisdiction. See, generally, 2 Collier on Bankruptcy, pp. 467 *et seq.* That, as appellant argues, it would be more convenient or tidy to have the Referee dispose of the entire controversy, rather than relegating the landlord to his suit against the Bank in the state court, cannot overcome this problem of lack of fundamental power.

Conclusion.

For the foregoing reasons, the Order of the Honorable William M. Byrne, United States District Judge, dated May 22, 1962, affirming the Order of the Referee in Bankruptcy, should be affirmed.

Respectfully submitted,

QUITTNER, STUTMAN & TREISTER,
By GEORGE M. TREISTER,
Attorneys for Appellee-Trustee in Bankruptcy.

Certificate.

I certify that, in connection with the preparation of this brief, I have examined Rules 18 and 19 of the United States Court of Appeals for the Ninth Circuit, and that, in my opinion, the foregoing brief is in full compliance with those rules.

GEORGE M. TREISTER

1850

No. 18143

IN THE

United States Court of Appeals

FOR THE NINTH CIRCUIT

LAMA COMPANY, a corporation,

Appellant,

vs.

UNION BANK, *et al.*,

Appellees.

APPELLANT'S REPLY BRIEF.

FILED

JAN 11 1963

JULIUS A. LEETHAM,

FRANK H. SCHMID, CLERK

832 Citizens National Bank Building,

453 South Spring Street,

Los Angeles 13, California,

Attorney for Appellant, Lama Company.

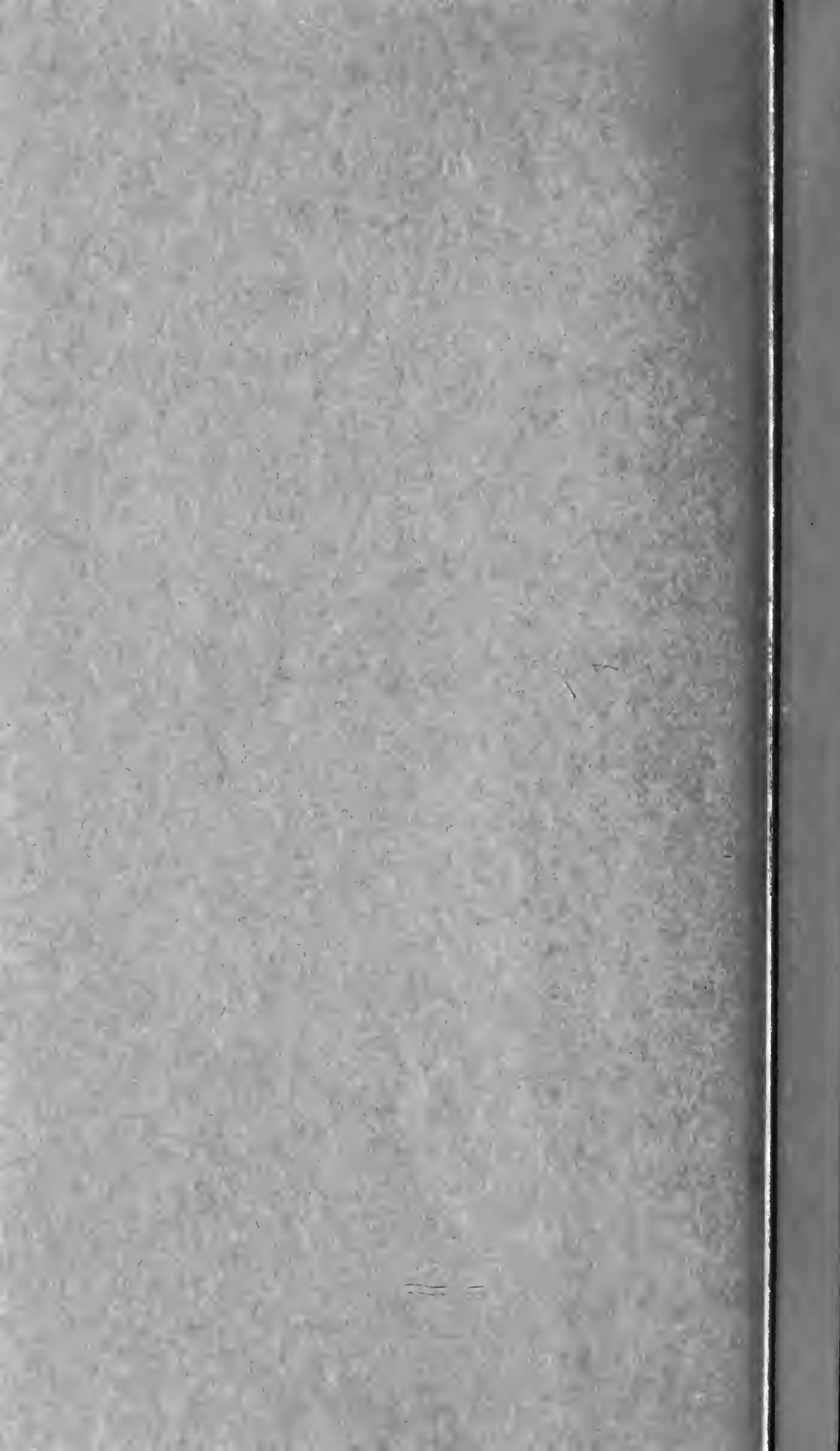

No. 18143

IN THE

United States Court of Appeals

FOR THE NINTH CIRCUIT

LAMA COMPANY, a corporation,

Appellant,

vs.

UNION BANK, *et al.*,

Appellees.

APPELLANT'S REPLY BRIEF.

RESPONSIVE ARGUMENT.

The Appellee, Union Bank, Having Been Found Benefited by Reason of Proportional Occupation of Premises in Bankruptcy Should Be Held Responsible for Its Aliquot Share of the Rent Burden.

Both appellees make the triumphant assertion that no transcript of the oral proceedings in this matter has been presented for review. This is true. It is submitted, however, that the conclusion both appellees reach from this circumstance, *viz.* that appellant's record is fatally defective, is unsound. Rather, it would be fair to say that *the Findings of Fact made by the bankruptcy court are to be accepted as true, and supported by the evidence.* Neither review nor appeal having been taken by either appellee, certainly it is too late for the nebulous argument by appellee that the Referee should not have made specific findings. (See Appellee

Union Bank's Br. p. 9.) Surely, a party cannot sit idly by while participating in a proceedings, and permit evidence and determination contrary to his interests—then contend at a later time that the finding was improper.

It is important to realize, then that the following undisputed facts exist in this matter :

1. The rental accrual on the subject premises would have been \$2,105.28 for the period in question. [Tr. p. 42.]

2. The personalty in which the bankruptcy estate had an interest occupied only one-third of the premises; that in which appellant Union Bank had an interest, occupied two-thirds of the premises. [Tr. p. 41.]

3. The bankruptcy estate should be liable to the appellant for \$701.60, or one-third of the value of the premises for the period, plus certain specified minor charges. [Tr. pp. 41-42.]

4. The appellee Union Bank received value for the use of two-thirds of the premises. [Finding of Fact VI, Tr. p. 41.]

5. Full and adequate notice of appellant's "claim" against appellees was given by appellant's petition and order to show cause, as evidenced by appellees responsive pleadings. [Tr. pp. 2-16.] Both appellees were present and ably represented at the bankruptcy hearing. [Tr. p. 39.]

The appellee Union Bank confidently cites the well-reasoned case of *Evarts v. Eloy Gin Corp.*, 204 F. 2d 712, together with most of the citations contained in that case as determinative here. The scholarly classifi-

cation of *Evarts*, although helpful for a general evaluation of bankruptcy jurisdiction, presents a factual situation vastly different than the one here. The essential question determined negatively in *Evarts* was whether a suit in simple contract for services could be brought in a bankruptcy court by an individual non-bankrupt against other non-bankrupt individuals and corporations merely on the basis that a debtor proceedings (subsequently dismissed) had existed with respect to some of the corporations for a temporary period. Logically, the Court held that a “controversy” or a “proceeding in bankruptcy” could not be expanded to this extent. In this case, the bankrupt’s leasehold right was an asset of the estate until surrendered. The claim made and the actual finding of the bankruptcy court is to the effect that the partie’s appellee herein actually made a joint arrangement concerning the bankrupt estate’s personalty, and disposed of the same by joint auction. [Tr. pp. 3 and 40.] The personalty was disposed of by an auctioneer jointly engaged by the appellees. [Tr. p. 41.] The trustee undertook the protection of *all* of the personalty assets prior to the sale. [Tr. p. 40.] This is in no sense the *Evarts* case.

The appellant landlord was restrained in the bankruptcy proceedings from the use of his property. The Referee attempted to apportion responsibility for rent, during the applicable administrative period. The appellee Union Bank was part and parcel of this controversy or bankruptcy proceedings. Asserting title to personalty within the estate, the appellee Union Bank certainly had no right to stand aloof, claiming the estate’s property but attempting to avoid the burdens of such claim by special appearance. By the act of injecting itself

into the bankruptcy proceedings to reclaim and redeem its personalty rights, as a matter of logic, the appellee Union Bank had submitted itself to the bankruptcy court's jurisdiction. The bankruptcy court's error lay simply in declining to effectuate its own determination.

Respectfully submitted,

JULIUS A. LEETHAM,
Attorney for Appellant, Lama Company.

Certificate.

I certify that, in connection with the preparation of this brief, I have examined Rules 18 and 19 of the United States Court of Appeals for the Ninth Circuit, and that, in my opinion, the foregoing brief is in full compliance with those rules.

JULIUS A. LEETHAM

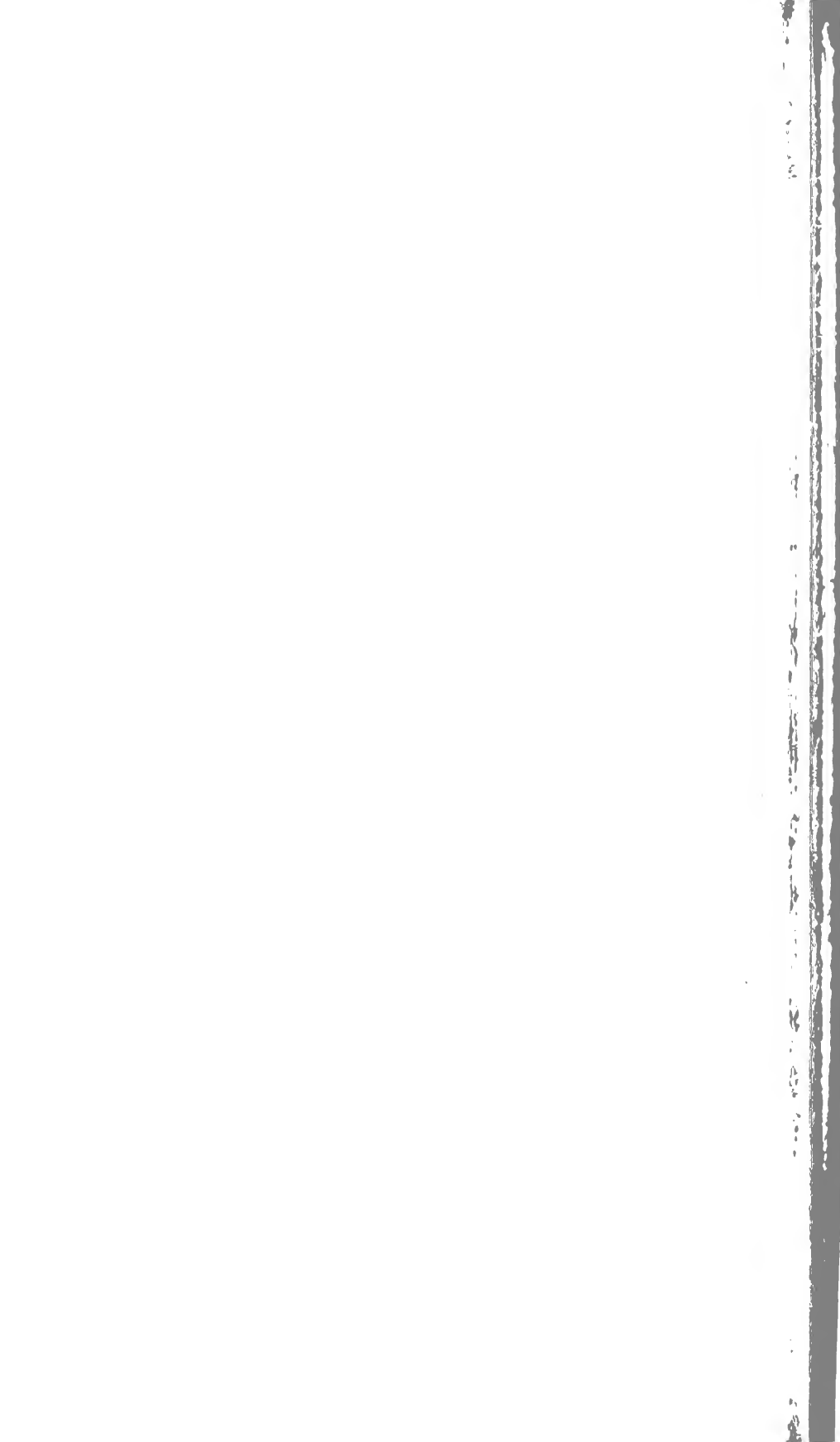

TOPICAL INDEX

| | PAGE |
|--|-----------|
| I. | |
| Statement of jurisdiction..... | 1 |
| II. | |
| Statement of the case..... | 2 |
| III. | |
| Error specified | 2 |
| IV. | |
| Statement of facts..... | 2 |
| Government's case | 2 |
| Defense | 5 |
| Offer of proof..... | 8 |
| V. | |
| Argument | 9 |
| Entrapment as a matter of law was not established by the evidence upon which the trial court rested its decision..... | 9 |
| VI. | |
| Conclusion | 14 |
| Appendix A. Excerpts are taken from the Reporter's Tran- script of appellant's testimony, on direct examination at pages 78 and 81, inclusive..... | App. p. 1 |

TABLE OF AUTHORITIES CITED

| CASES | PAGE |
|---|------|
| Arena v. United States, 226 F. 2d 227, cert. den. 350 U. S. 954 | 10 |
| Lutfy v. United States, 198 F. 2d 760..... | 12 |
| Masciale v. United States, 356 U. S. 386..... | 14 |
| Sherman v. United States, 356 U. S. 369..... | 11 |
| Torres Martinez v. United States, 220 F. 2d 740..... | 13 |
| United States v. Glasser, 315 U. S. 60..... | 9 |

RULES

| | |
|--|---|
| Federal Rules of Criminal Procedure, Sec. 23a..... | 2 |
|--|---|

STATUTES

| | |
|--|---|
| United States Code, Title 18, Sec. 1407..... | 1 |
| United States Code, Title 18, Sec. 3231..... | 1 |
| United States Code, Title 21, Sec. 173..... | 1 |
| United States Code, Title 21, Sec. 174..... | 1 |
| United States Code, Title 28, Sec. 1291..... | 1 |
| United States Code, Title 28, Sec. 1294..... | 1 |

No. 18149
IN THE

United States Court of Appeals
FOR THE NINTH CIRCUIT

LEONARD JOSEPH BLACKWELL,

Appellant,

vs.

UNITED STATES OF AMERICA,

Appellee.

APPELLEE'S BRIEF.

I.

STATEMENT OF JURISDICTION.

Appellant was adjudged guilty by the United States District Court for the Southern District of California of (1) illegally importing methadon, a narcotic drug, (2) concealing and facilitating the concealment and transportation of the same methadon, both in violation of Title 21, United States Code, Sections 173 and 174, as charged in Counts One and Two respectively; and (3) failing to register with a Customs official as a convicted violator of a narcotic law of the State of California, in violation of Title 18, United States Code, Section 1407, as charged in Count Three of the Indictment.

The offenses occurred in San Diego County in the Southern Division of the Southern District of California. The District Court had jurisdiction by virtue of Title 18, United States Code, Section 3231.

This Court has jurisdiction to entertain this appeal from the judgment under Sections 1291 and 1294 of Title 28, United States Code.

II.

STATEMENT OF THE CASE.

Appellant is charged in a three count Indictment, returned December 6, 1961, with the violations set forth above. Appellant plead guilty to Count One on December 12, 1961, but thereafter on January 2, 1962, the plea of guilty was set aside and the case proceeded to trial by the Court on all three counts on March 13, 1962, the Appellant having waived jury pursuant to Section 23a of the Federal Rules of Criminal Procedure.

On March 26, 1962, the Court found Appellant guilty of all three counts and sentenced him to five years imprisonment on each of Counts One and Two to run concurrently and on Count Three imposition of sentence was suspended and Appellant was placed on probation for a period of five years.

Timely notice of appeal was filed by Appellant who was permitted to proceed *in forma pauperis*.

III.

ERROR SPECIFIED.

Appellant has specified in effect that the trial court erred in not acquitting Appellant in that the evidence upon which the Court rested its decision established entrapment as a matter of law.

IV.

STATEMENT OF FACTS.

Government's Case.

At approximately 4:20 p.m. on November 12, 1961, Appellant walked into the United States from Mexico at the San Diego (San Ysidro) Port of Entry in San Diego County [R. T. 17-19, 20]¹. Appellant stated

¹R. T. refers to Reporter's Transcript of Proceedings.

to the Customs Inspector in the pedestrian line that he was a citizen of the United States and was bringing nothing into the United States from Mexico. He then proceeded a few yards beyond this first inspection point where he was interrogated by another Customs Inspector [R. T. 2]. In response to further inquiry Appellant declared nothing other than a piece of lace [R. T. 22].

Appellant had not registered as a narcotics violator nor attempted to register by the surrender of any certificate or in any other manner [R. T. 18, 23, 24]. Inspector LeRoy Riddlespurger then conducted a personal search of Appellant in the Customs House at which time he observed scarring on both arms and learned that Appellant had been arrested for possession of heroin on a prior occasion. No contraband was found at that time [R. T. 23]. Inspector had information to look out for Appellant. [R. T. 26]. Appellant was requested to remain at the office as a suspected violator of 1407 [R. T. 24, 30]. Appellant did not appear to be under the influence of a narcotic drug [R. T. 28].

Customs Agent Maxcy arrived at the Port of Entry about 5:35 p.m. that same day and interrogated Blackwell at which time he told the agent that he had arrived in the San Diego area and proceeded to Tijuana, Mexico, having arrived the morning of November 12 by airplane from San Francisco and that the purpose of his trip to Tijuana was to go to the race track and to visit a friend of his who lived in the area. He admitted he had been convicted on a charge for the sale of narcotics in the San Francisco area in June of 1960 [R. T. 33, 34].

Appellant was placed under arrest for failing to register as a prior narcotics violator and booked at the San Diego County Jail about 7:00 p.m. on November 12, where he remained under surveillance of jail officials. [R. T. 34, 35, 48]. Agent Maxcy returned to the County Jail and was present at the medical dispensary the following day at about 8:00 a.m. [R. T. 35]. At that time the jail physician examined Blackwell's arms and attempted to probe his rectum, during which time Blackwell was uncooperative and the doctor was unable to perform a satisfactory search [R. T. 36]. Following this Agent Maxcy was present with the Appellant at the San Diego County Jail from about 10:00 a.m. until 10:55 a.m. when Appellant stated to the Customs Agent that he had a quantity of heroin concealed in his rectum which he excreted at that time [R. T. 37, 38]. [Ex. I-A]. This substance was retained by the Customs authorities, analyzed by a Customs chemist and found to be methadon hydrochloride, a narcotic drug. [R. T. 38, 5-9, 10-16]. The Appellant stated regarding the contraband which was recovered from him that he had come from San Francisco the morning of November 12; that his sole purpose in coming to Tijuana was to purchase heroin; that he had purchased the narcotics from a man named Tony in Tijuana, that he had paid the sum of \$150.00 for it, that it was all for his own use or for sale; and that upon returning to San Francisco he intended to sell it there. [R. T. 39, 40].

On cross-examination Agent Maxcy testified that he had information from a fellow agent that there was reason to believe that Blackwell had contraband concealed in his rectum. [R. T. 42]. It was stipulated

that there was information that Blackwell had brought a narcotic drug into the United States, that information had been received from this source in prior cases, and that the informer had received compensation for this information in accordance with the usual general practice [R. T. 42-44]. Agent Maxcy testified further that while a rectal probe was attempted it was never made to the satisfaction of the doctor and that a constant surveillance was maintained over Blackwell [R. T. 47-48]. The first time that Blackwell admitted that he had a narcotic substance contained in his rectum was shortly before 11:00 o'clock on November 13 [R. T. 41-50]. Agent Maxcy also checked the records pertaining to the registration of Appellant and found no evidence of Appellant having registered before he left the United States or returned to the United States on November 12, 1961 [R. T. 51].

The judgment pertaining to Blackwell's prior conviction was received in evidence as Exhibit 3 and it was stipulated that Blackwell at all times mentioned in Count Three was a citizen of the United States [R. T. 53].

Defense.

Customs Inspector Riddlespurger was called as a witness for appellant and testified that three or four minutes after Blackwell entered the United States a person named Willie Dean entered the United States in the pedestrian lane [R. T. 56]. Willie Dean went to the office to register as a narcotics addict where he was given a personal search also. He was not observed to be under the influence of a narcotic nor did he have any contraband on his person and the Inspector released

him [R. T. 57, 58]. At the time Dean left the office and was going out the door he advised Inspector Riddle-spurger that Blackwell had narcotics on his person somewhere [R. T. 60].

Appellant testified in his own behalf that he had never visited San Diego or been to Mexico before this occasion [R. T. 64]. He testified he was using narcotics at the time he was arrested and had been using narcotics off and on since 1949 [R. T. 64]. He admitted having plead guilty to the charge of possession of narcotics [Ex. 3] [R. T. 65].

Appellant testified he first met Willie Dean in San Francisco on Saturday night, November 11, and that although he had seen him before he had never had any personal acquaintance with him. That he knew of Willie Dean as an addict and seller of narcotics. [R. T. 68]. That after being in another friend's house Appellant was asked to drop Dean off at his hotel. That he drove Dean back to his hotel and Dean told him about the fact that he had contacts in Mexico where he could get "the stuff for and good quality." Appellant testified that Dean importuned him to go to Mexico to obtain narcotics; that it was easy for Dean to contact people there; that good quality "stuff" could be obtained cheap there; and that there was little risk in going to Mexico [R. T. 68-69]. Blackwell stated that Dean impressed upon him that it was something Blackwell couldn't afford to pass up, so appellant went to different acquaintances and borrowed money [R. T. 70]. Blackwell stated further that after arriving in San Diego he and Dean stopped at Dean's relatives house in San Diego where they left the airline tickets at

Dean's suggestion; that the two hitchhiked to Mexico; that Appellant was not going into Mexico at first as Dean was to bring "it" in, but after coming this far he was inclined to follow Dean into Mexico to keep him from just running off with any money and not coming back [R. T. 74]; that Dean registered but suggested that Blackwell go across without registering because they didn't have any reason to stop him because they didn't know him [R. T. 75]. That Dean then met Blackwell in Mexico south of the Border and they rode around in a taxi until they met a man named Tony [R. T. 76]; that this cab driver then took Dean and Blackwell to a motel where they registered, took a room and waited for him to get the merchandise [R. T. 77]. That Tony brought the merchandise "back to the motel room where Dean tested it and appeared to pass out." That Dean left him with the narcotics and he thereafter concealed it in his rectum after which they returned to the Border. That Appellant had paid for the narcotics after the test had been made by Dean [R. T. 85, 86]. See Appendix A.

On cross-examination Appellant admitted that he had previously been convicted for narcotics violation, the conviction of which was introduced into evidence as Exhibit 3 and also had two prior felony convictions [R. T. 89]. He had obtained more than \$150.00 because he had to pay expenses down and the \$150.00 was the actual cost [R. T. 91]. He admitted that he had told Agent Maxcy that the sole purpose of the trip was to purchase heroin; that he had purchased the "heroin" and that it was his money [R. T. 93, 94].

Offer of Proof.

Appellant offered to prove further by the testimony of Willie Dean that he had informed on other occasions and had received remuneration from the government on those occasions.² [R. T. 128-129].

Appellant also offered to prove by the testimony of a person named Large, who had come to San Diego for the purpose of obtaining narcotics, that Dean had assisted him in purchasing heroin in Mexico in the same manner as testified to by Appellant in this instance; and that Dean turned Large into Customs authorities using the same "technique." [R. T. 130].

Appellant offered to prove by Customs Agent Maxy that William Dean informed on other persons on prior occasions and received remuneration and special privileges from the government on these occasions [R. T. 130-132].

²Willie Dean was called by the defense and testified [R. T. 96-120] but since his testimony did not enter into the decision of the Court it will not be included in this brief.

V.

ARGUMENT.

Entrapment as a Matter of Law Was Not Established by the Evidence Upon Which the Trial Court Rested Its Decision.

The undisputed facts show that while in Mexico Appellant placed a narcotic drug in his rectum; that he then proceeded to the San Diego Port of Entry where he walked into the United States without registering as a convicted narcotic violator, maintaining at the time of his entry at 4:20 p.m. on November 12, 1961; and thereafter for a period continuing until about 11:00 a.m. the following day that he did not have the narcotics which were in fact during this entire period concealed in his body cavity.

Notwithstanding these facts, Appellant contends the trial court could not find from Blackwell's own testimony, together with the facts assumed by the Court as presented in the offer of proof of Appellant, that Blackwell had voluntarily imported and concealed the heroin without any persuasion on the part of anyone. The claim in the offer of proof is essentially that Willie Dean, the informant in this case, had assisted a man named Large on a previous occasion to obtain narcotics by the "technique" testified to by Appellant in this case; that Dean had informed on Large and other smugglers and had received in return remuneration and special privileges from the Customs authorities.

The general rule is that if there is substantial evidence taking the view most favorable to the government to support a conviction, it should be sustained on appeal.

United States v. Glasser, 315 U. S. 60, 80 (1942).

In considering the facts, the reviewing court must ordinarily grant every reasonable intendment in favor of Appellee.

Arena v. United States, 226 F. 2d 227, 229 (9th Cir. 1956), Cert. Denied, 350 U. S. 954 (1956).

Limiting the argument to the testimony of Appellant and considering the offer of proof in the manner in which the trial court did, there is substantial evidence to support the findings of the trial court concerning the actions of Appellant upon which in turn the convictions rest.

Appellant testified he first met Willie Dean in San Francisco on a Saturday night, November 11, 1961, a person he had known as an addict and seller of narcotics. Blackwell stated that Dean importuned him in San Francisco to come down to obtain narcotics from Mexico. Blackwell admitted he had a prior narcotics conviction in 1960 which the evidence [Ex. 3] has shown was for the sale of narcotics.

Blackwell stated after Dean "stayed around . . . interesting me in this idea" that it was too good an opportunity to pass up; that it sounded good to him; that the narcotics would be cheap and good. Blackwell, that same night before he and Dean left San Francisco on the flight arriving at 11:00 a.m. in San Diego the following day, went to different acquaintances and raised the money for the narcotics. The narcotics were for the use of Blackwell as well as those other persons who had put money into it, and Blackwell would sell as much of it as would reimburse Blackwell for what he had put into it.

After arriving in San Diego, both Blackwell and Dean proceeded to Mexico where Blackwell gave as a reason for entering that “. . . naturally, I was inclined to follow him to keep him from just running off with my money and not coming back.” [R. T. 75, 76].

Blackwell then testified that Dean made the arrangements in Mexico for the purchase of narcotics with a man named Tony and that Blackwell gave Tony that money for the narcotics after Dean had tested “it” and convinced Blackwell “it was the real thing.” [R. T. 86]. Following that appellant said Dean “pretended” to pass out; that he tried to help Dean but that Dean went out and left him with the “merchandise” which he couldn’t leave there, so he concealed same himself in his rectum (See Appendix A).

Blackwell stated he did not use any narcotics in Mexico himself because he had to keep a clear head, and if he was going to use anything, it was to be after he came back to the United States [R. T. 84, 85]. Following the concealment of the narcotic in his body cavity, appellant entered the United States without registering as a narcotics violator or user, where, as stated, he denied the presence of any narcotic on his person until the following day when he finally ejected it.

Appellant has referred to the case of *Sherman v. United States*, 356 U. S. 369 (1958) for the proposition that his testimony and the offer of proof have shown entrapment as a matter of law. This case is distinguishable as follows: Appellant here was not an addict within the meaning of the *Sherman* case; and there was an abandonment of the narcotics by the alleged inducer a considerable period before the offenses

were committed, which were independent acts by Appellant not the result of either inducement or addiction. Not only did the Appellant himself state he did not use the narcotic while in Mexico, but there was no evidence that he was under the influence of narcotics or suffering from symptoms of narcotics addiction. Appellant testified further that he placed the narcotic in his rectum with a "clear head"; stating that he couldn't leave the "merchandise" in Mexico and had no choice but to bring it into the United States. His reasons for bringing the narcotic into the United States were not that he had a compelling need to use it, but that his investment and that of others would be lost if he did not import it in the manner in which he did.

The case of *Lutfy v. United States*, 198 F. 2d 760 (1952) is likewise distinguishable from the instant case. There the Appellant testified he had never been in any way engaged in the narcotic traffic before contact by government agents; never been arrested; or had narcotics in his possession; and had no intention of engaging in the narcotic traffic or dealing in narcotics, and procured the heroin for the agents only because they urged and insisted he do so.

Here the Appellant by his own testimony had previously been arrested and convicted of a narcotics violation which implied a possession of narcotics at that time; he evidenced an interest in buying narcotics had Willie Dean had them available in San Francisco; he procured with money he had raised the instant narcotics not only for his own use but for sale and the use of his financiers; and he secured the narcotic in a particularly individualistic and unnatural manner unper-suaded by any person at the time he did so.

By Appellant's own testimony, Dean left him entirely alone in Mexico and displayed no interest in taking any narcotics into the United States. He thereupon took action of the most independent and affirmative nature possible, the very nature of which, that of forcing a sizeable object into a place contrary to nature and maintaining it there for many hours, shrieks of the independence of his acts at that time and thereafter.

Of course, concealment which occurred during the period following importation is a separate and distinct offense, as charged in Count Two. As stated in *Torres Martinez v. United States*, 220 F. 2d 740 at page 742 (1st Cir. 1955):

“21 U. S. C. A. § 174 in the disjunctive establishes multiple offenses. It punishes not merely the act of selling, but also the act of fraudulently or knowingly importing narcotic drugs contrary to law, and the separate offenses, after such importation, of receiving, concealing, buying the same, or in any manner facilitating the transportation, concealment or sale thereof, knowing them to have been imported contrary to law. The language in *Burton v. United States*, 1906, 202 U.S. 344, 377, 26 S.Ct. 688, 697, 50 L. Ed. 1057, is applicable here, that ‘Congress intended to place its condemnation upon each distinct, separate part of every transaction coming within the mischiefs intended to be reached and remedied.’”

Aside from being a separate offense, this continued concealment for many hours is indicative of appellant's independent action in first concealing the narcotic, and inferentially supports the finding of the court that it

was initially secreted by an independent act not under the persuasion of anyone, thus negating the alleged entrapment.

The case of *Masciale v. United States*, 356 U. S. 386 (1958) indicates at page 387 that the undisputed testimony by a person that an informer engaged in a campaign to persuade him to sell narcotics by using the lure of easy income does not of itself establish entrapment as a matter of law where the facts concerning alleged entrapment are properly considered by the fact finder.

The trial court has properly determined the issue of entrapment by virtue of its findings of fact which are amply supported by the evidence which was considered. The facts found do not establish entrapment as a matter of law and appellant is therefore not entitled to acquittal.

VI.
CONCLUSION.

For the foregoing reasons, it is respectfully submitted that the District Court's finding of guilt should be affirmed as to all counts.

Respectfully submitted,

FRANCIS C. WHELAN,
United States Attorney,

THOMAS R. SHERIDAN,
Assistant U. S. Attorney,

ELMER ENSTROM, JR.,
Assistant U. S. Attorney,

No. 18149
IN THE

United States Court of Appeals
FOR THE NINTH CIRCUIT

LEONARD JOSEPH BLACKWELL,

Appellant,

vs.

UNITED STATES OF AMERICA,

Appellee.

Certificate.

I certify that, in connection with the preparation of this brief, I have examined Rules 18 and 19 of the United States Court of Appeals for the Ninth Circuit, and that, in my opinion, the foregoing brief is in full compliance with those rules.

FRANCIS C. WHELAN,
United States Attorney,

THOMAS R. SHERIDAN,
Assistant U. S. Attorney,
Chief, Criminal Section,

ELMER ENSTROM, JR.,
Assistant U. S. Attorney,
Attorneys for Appellee,
United States of America.

J

1

1

1





APPENDIX A.

The following excerpts are taken from the Reporter's Transcript of Appellant's testimony, on direct examination at pages 78 and 81, inclusive:

"A. Well, after Tony brought this merchandise back, why, he put it on the dresser, and I opened it and examined it, and Dean, he also tested it, to determine whether it was what we was paying for. And as I said at first, I mean this was his agreement, to bring this back, but I think this is how I happened to end up with it—

Q. Please describe what happened. A. Dean tested the stuff and —

Q. Did he give you some A. And he gave me some, and the impression he gave me was that he had an overdose, or he was on the verge of passing out.

Q. Would you describe his actions to us? A. He just went to scratching all over his head, and all over his body, and pulling his clothes — you know, pulling his top clothes off, and, naturally, I was kind of excited and afraid he might have had an overdose, and that is dangerous, and I was kind of excited because it seemed that he might pass out.

Q. What did you do then? Did you do anything to try to keep him from passing out? A. I tried to keep him from passing out, and, also, I give him a bottle of this methadon. It counteracts narcotics. It is a stimulant, see, and I was trying to keep him from passing out, because we was over there, and we have to come back, and in the shape he is in, I know he has to come through the Cus-

toms and the inspection, and that he couldn't make it in that condition, and I was thinking of all of this.

Q. How did he talk? A. Well, his conversation didn't even — his words didn't even tie in in his conversation. I mean, he just acted like he had an overdose. He told me about how good it was, and that it was dynamite, and so forth, that it was real good quality, but Dean —

Q. About what time did this take place? A. Well, we got over there — we got into San Diego at about 11:00, and this was about 1:30 or 2:00 o'clock in the motel.

Q. And you had the plane to catch at around 5:00 o'clock? A. Yes.

Q. Would you describe what happened there in the next few hours? A. Well, after he didn't seem like he was going to come around — to come back to normal, I asked him if — I kept reminding him that we had to get across the Border, and we had our reservations for a certain time, and it seemed like he didn't care, or that he was just killing time, or didn't even care whether we got back or not.

And I just figured it was due to his having used too much. And he even left out of the room, and left me in there with this merchandise.

Now, I mean before he left, I asked him if he was going to make preparations so that we could leave and go back. In other words, I am asking him if he is going to wrap this stuff up and get ready, so that we can go.

But he told me that it didn't make him any difference. And so I didn't—well, I mean I didn't want it. But I had the impression that he wouldn't hardly make it back no how, not in the condition he was in. I was certain that he would be stopped if he tried to make it back with this merchandise, that he would probably get posted.

Q. After the time went by, and he was out of the room, you say he was down talking to someone else? Do you know who he was talking to? A. Well, after he left me, he was down talking to the hotel manager, and he was still talking, and this all seemed unnecessary talk, it seemed to me. He was talking about how good the motel was, and if he came back to Mexico he wanted to visit there and stay around the motel.

And it was getting late, and actually I couldn't leave the merchandise there, and it didn't seem like he would be able to make it back nohow, and it didn't seem like he had no intentions of taking it back anyway after we got over there.

Q. What did you do then? A. Well, I concealed it myself, because he didn't leave me no choice.

Q. And as to the technique, did you use the technique that he had told you about? A. I concealed it in my rectum, as he told me he had done previously, and he was present on this trip.

Q. Was he present when you did this? A. No."

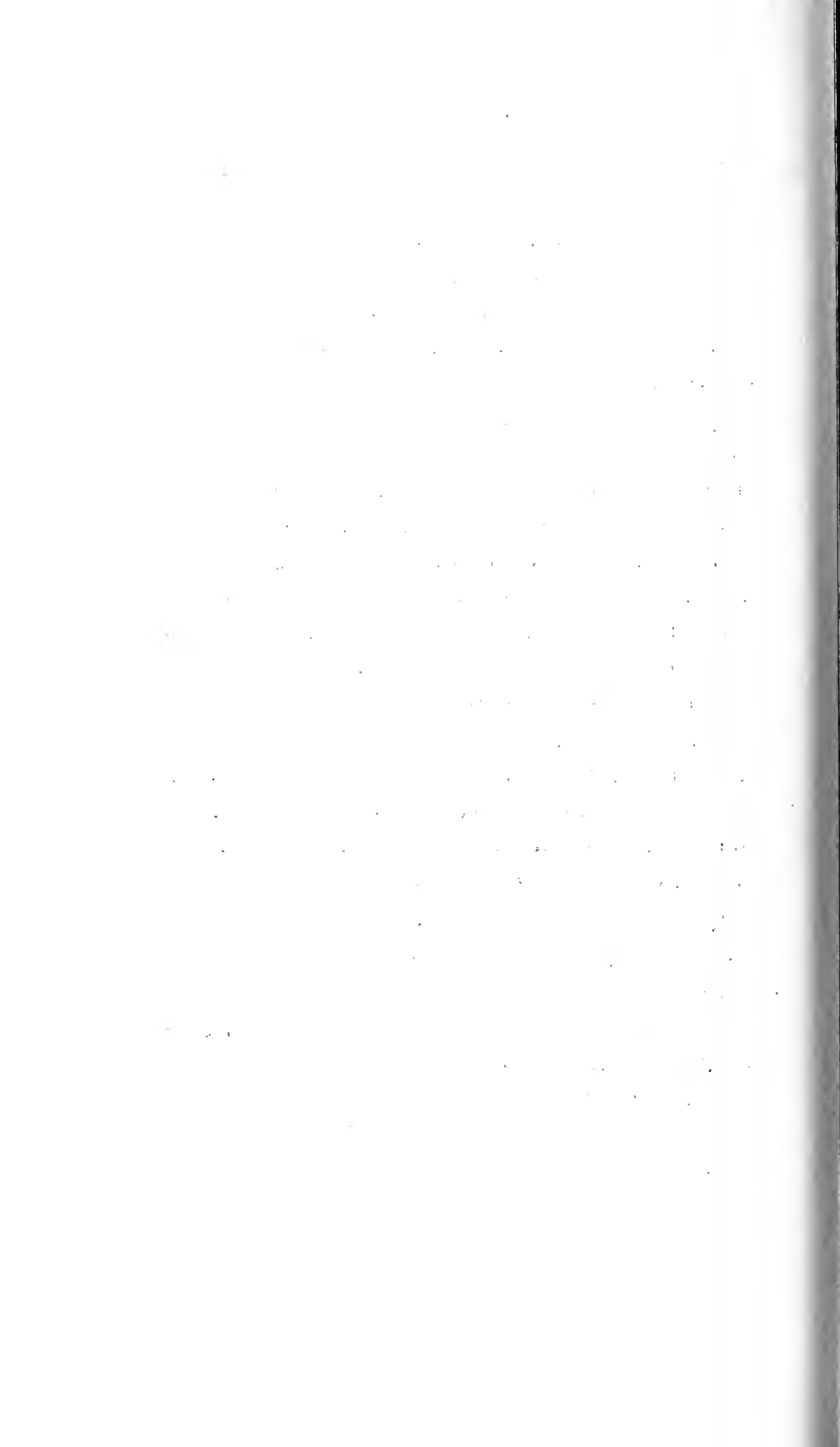

United States Court of Appeals

FOR THE NINTH CIRCUIT.

WARREN H. LOCKWOOD and
MID-WEST METALLIC PRODUCTS, INC.,

Appellants,

vs.

LANGENDORF UNITED BAKERIES, INC. and
BANNER METALS, INC.,

Appellees.

OPENING BRIEF OF APPELLANTS.

BRONSON, BRONSON & MCKINNON,
JOHN F. WARD,

John Hancock Building,
255 California Street,
San Francisco 11, California,

MEYER, BALDWIN, DORAN & EGAN,
GEORGE S. BALDWIN,

1430 Keith Building,
Cleveland 15, Ohio,

ROUDEBUSH, ADRIAN, BROWN, CORLETT & ULRICH,
MYRON W. ULRICH,

915 Williamson Building,
Cleveland 14, Ohio,

Attorneys for Appellants.

FILED

DEC 14 1962



TABLE OF CONTENTS.

| | |
|--|----|
| I. Jurisdiction of the Action | 1 |
| II. Statement of the Case | 2 |
| A. Summary of the Facts | 2 |
| B. Issues in the Case | 9 |
| 1. Trial on the Complaint | 9 |
| 2. The Trial on the Counter Claim | 9 |
| C. The Invention of Lockwood Patent No. 2,931,535 | 11 |
| D. The Invention of Lockwood Reissue 24,731 .. | 15 |
| E. Defendants' Accused Device | 15 |
| III. Specifications of Error | 16 |
| IV. Summary of Argument | 17 |
| V. Argument | 20 |
| 1. No Justiciable Issue as to Ex. 9 Infringing Re-issue Patent, Nor as to Ex. O Infringing '535 Patent | 20 |
| 2. Exhibit 9 Infringes Claims 19 and 20 of the '535 Patent | 30 |
| The "Dimensions" Clause | 32 |
| The "Clearways" Clause of Claims 19 and 20 of the '535 Patent | 36 |
| 3. The '535 Patent Is Not Anticipated by Prior Faulkner Patent 2,252,964 | 38 |
| 4. The '535 Patent Is Not Anticipated by Prior Blom Patent 2,684,766 | 41 |
| 5. Exhibit 9 Infringes Claims 21 to 28 of the '535 Patent | 45 |

| | |
|---|----------|
| 6. Exhibit O Infringes Claims 20 to 23 and 25 of the '535 Patent | 46 |
| 7. Exhibit 9 Infringes Claim 7 of Reissue 24,731 | 47 |
| 8. Claim 7 of Reissue 24,731 Is Valid | 49 |
| Finding of Invalidity of Claim 7 of Reissue 24,731 on the Ground No "Error" Alleged to Justify the Reissue | 49 |
| Finding of Invalidity of Claim 7 on the Ground That the Invention Claimed Therein Was Different From the Invention in the Original Patent | 52 |
| Finding of Invalidity of Claim 7 on the Ground That the Subject Matter Claimed in the Reissue Patent Was in Public Use and on Sale in the United States More Than One Year Prior to the Filing of the Reissue Application | 53 |
| VI. Recapitulation and Conclusion | 56 |
| Appendices: | |
| I. U. S. C. A. Section 251 | 59 |
| II. Quotations from <i>Seymour v. Osborne</i> and <i>Topliff v. Topliff</i> | 60 |
| Plates I, II, IIA, III, IV and V | Attached |

TABLE OF AUTHORITIES.

Cases.

| | |
|--|--------|
| <i>Beidler v. Photostat Corp.</i> , 10 F. Supp. 628, affirmed 81 F. (2d) 1015 ----- | 24, 26 |
| <i>Chicago Pneumatic Tool Co. v. Hughes Tool Co.</i> , 61 F. Supp. 767, aff. 156 Fed. 981 ----- | 28 |
| <i>Crane Packing Company v. Spitfire Tool & Machine Co.</i> , 276 F. 2d 271 ----- | 53 |
| <i>Dugan v. Lear Avia</i> , 55 F. Supp. 223, aff. 156 F. 2d 29 | 23 |
| <i>Funchion v. Sommerset Knitting Co., Inc., et al.</i> , 158 F. Supp. 57 ----- | 51, 53 |
| <i>Hartzell Industries, Inc. v. McCauley Industrial Cor- poration</i> , 304 F. 2d 481 (June 26, 1962) ----- | 55 |
| <i>Hobbs v. Beach</i> , 21 S. C. 409, 180 U. S. 383, 45 L. Ed. 586 ----- | 51 |
| <i>Marlott v. Mergenthaler Linotype Co.</i> , 70 F. Supp. 426 ----- | 24 |
| <i>Moist Cold Refrigerator Company, Inc. v. Lou John- son Company, Inc.</i> , 217 F. 2d 39 ----- | 50 |
| <i>New Wrinkle, Inc. v. Fritz</i> , 30 F. Supp. 89 ----- | 23 |
| <i>Research Electronics and Devices Co., Inc. v. Neptune Meter Company</i> , 156 F. Supp. 484, Aff. 264 F. 2d 246 ----- | 29 |
| <i>Seymour et al. v. Osborne et al.</i> , 76 U. S. 516, 20 L. Ed. 33 ----- | 51, 60 |
| <i>Topliff v. Topliff et al.</i> , 145 U. S. 156, 36 L. Ed. 658 | 51, 61 |
| <i>Treemond Co. v. Schering Corporation</i> , 122 F. 2d 702 ----- | 25, 27 |
| <i>Union Asbestos and Rubber Company v. The Paltier Corporation</i> , 298 F. 2d 48 ----- | 54 |

Texts.

Borchard's Declaratory Judgments (2 ed.), page 807 25

Statutes.

| | |
|------------------------------|-----------|
| 28 U. S. C. A. 1291 ----- | 2 |
| 28 U. S. C. A. 1338(a) ----- | 1 |
| 28 U. S. C. A. 2201 ----- | 1, 18, 24 |
| 28 U. S. C. A. 2202 ----- | 1 |
| 35 U. S. C. A. 251 ----- | 20, 49 |
| 35 U. S. C. A. 271(a) ----- | 22 |
| 35 U. S. C. A. 281 ----- | 23 |
| 35 U. S. C. A. 282 ----- | 23, 56 |

No. 18,159.

United States Court of Appeals

FOR THE NINTH CIRCUIT.

WARREN H. LOCKWOOD and
MID-WEST METALLIC PRODUCTS, INC.,

Appellants,

vs.

LANGENDORF UNITED BAKERIES, INC. and
BANNER METALS, INC.,

Appellees.

OPENING BRIEF OF APPELLANTS.

I. JURISDICTION OF THE ACTION.

This action for the infringement of a United States Letters Patent was brought in the United States District Court for the Northern District of California, Southern Division, pursuant to provisions of Title 28 U. S. C. A. Section 1338(a) as was set forth in paragraph IV of the Complaint and admitted in paragraph 4 of the First Amended Answer to the Plaintiff's Complaint as amended.

A Counter Claim praying for a declaratory judgment as to the validity and infringement of certain patents was filed in this action pursuant to Title 28 U. S. C. A. Sections 2201, 2202 as set forth in paragraph 24 of the First Amended Answer to Plaintiff's Complaint and Defendants' Counter Claim for Declaratory Judgment and admitted in the Plaintiff's Answer to Defendants' Counter Claim.

The District Court found it had jurisdiction of this action in Paragraph 1 of its Conclusions of Law.

The Appeal and Cross Appeal were taken from the final order of the District Court entered May 9, 1962 to this Court pursuant to the provisions of Title 28 U. S. C. A. Section 1291.

II. STATEMENT OF THE CASE.

A. SUMMARY OF THE FACTS.

Warren H. Lockwood is the inventor and owner of both United States Letters Patent at issue in this action (R. 85, 89). Mid West Metallic Products, Inc. is an Ohio Corporation with its place of business in Cleveland, Ohio and is the holder of an exclusive license from Lockwood to manufacture, use and sell devices covered by the patents at issue in this action. (R. 50, Ex. 7.) These parties were the plaintiffs in the action in the District Court and are the appellants in the principal appeal and appellees in the Cross Appeal. To simplify identification we will call them "Lockwood" and "Mid West" or the "plaintiffs" as the occasion requires.

Banner Metals, Inc. is an Ohio corporation with its place of business at Compton, California and Langendorf United Bakeries, Inc. is a Delaware corporation and has its principal place of business in San Francisco, California. (Pars. 3 and 10, Deft's. amended answer.) These parties were the defendants in the District Court and are the appellees in the principal appeal filed in this Court and appellants in the Cross Appeal. We will call them "Langendorf" and "Banner" or the "defendants" as the occasion requires.

In the spring of 1952, Lockwood, while employed by Coleman-Pettersen Company, a predecessor Company of Banner, conceived an invention which permitted like receptacles or containers to tier one on top of another in

vertical alignment when full and to nest in vertical alignment when empty without the use of moving parts. On September 16, 1952, he filed an application for United States Letters Patent at his own expense through his own patent attorney. For the next two and one half years he sought to incorporate his invention into a acceptable commercial form and unsuccessfully sought to interest his employer (still a predecessor to Banner) in developing said invention into a commercial product. (R. 85-88.)

In February, 1955, Mid West, believing Lockwood's invention could be used to solve a specific customer problem, entered into an exclusive license agreement with Lockwood. Mid West then spent the next six months incorporating the invention into a wire container serving as the principal component of a handling system for bakery products. This system, although composed of separate nestable and tierable containers, could be handled as single locked units. (R. 46, 48, 49, Ex. 3a-3b.) Some 300,000 of the containers incorporating the first patent have been sold. (R. 62.)

In March, 1955, Lockwood became a manufacturer's agent for Mid West in the West Coast territory to sell the system incorporating his first invention. (R. 90.)

The first invention provided for a structure the characteristics of which permitted tiering or nesting by rocking or tilting the bottom of the upper container under the top support parts of the lower container. (R. 39, 40 Ex. 1.)

During the period that Mid West was developing a commercial article incorporating the first invention, Lockwood continued to work with tiering and nesting containers and discovered that by use of other structures the tiering and nesting of like receptacles in vertical alignment could be accomplished without moving parts by rotating

the upper receptacle or by moving the upper receptacle laterally (shifting). (R. 90, Ex. 8.) This invention was incorporated in an application for United States Letters Patent by Lockwood and filed on February 6, 1957. (Ex. 6).

On February 26, 1957, Lockwood's first patent was issued bearing the number 2,782,936. This covered the rocking or tilting type of manipulation. (Ex. 4).

In August, 1955, Banner acquired the assets of its predecessor Company and later manufactured and offered to sell to the bakery trade a container which tiered and nested by use of a rocking or tilting type of action. The appearance of said container was so similar to that developed and sold by Mid West that a suit was filed by Mid West in the United States District Court for the Northern District of Ohio at Cleveland against Banner for infringement of a design patent issued to Glezen. (R. 67, 383.)

Thereafter, retaining the basic characteristics which made tiering and nesting possible by use of the rocking motion, but altering its physical appearance, Banner manufactured and sold a number of containers to the bakery trade for use as transport rack and in competition with Mid West container incorporating Lockwood's first patent. Thereafter, Lockwood and Mid West filed a suit against Banner in the United States District Court at Cleveland in July, 1957 for infringement of Lockwood's first patent based on said sales. (R. 51.)

In August, 1957, Banner filed a declaratory judgment action in the Superior Court of the State of California in and for the County of Los Angeles against Lockwood and Mid West claiming title to or a shopright in Lockwood's first patent by reason of his employment with its predecessor Company at the time the invention was made. (R. 51.)

On September 3, 1958, the Superior Court entered judgment for Lockwood finding Banner had neither the title to nor a shop right in the first Lockwood patent. This judgment was affirmed on appeal and the Supreme Court of California refused to review the judgment. (R. 52, 387.)

On January 12, 1959, Lockwood filed an application to reissue his first patent by adding Claims 6 and 7 to set out the claim that structures having the upper and lower support points vertically above each other in receptacles in tiered position associated with characteristics which permitted nesting in vertical alignments was a basic or generic claim which applied to all types of manipulation whether rocking, shifting or rotating. The reissue patent No. 24,731 was issued November 3, 1959 in the form applied for. (Exs. A, C-7.)

In the winter of 1959, Langendorf was interested in obtaining nesting, tiering wire containers for transporting so-called "sweet" baked goods, that is cakes, sweet rolls and like items. Wilson, Vice President of Banner, saw Langendorf about these requirements in February, 1959 and started to sketch possible containers for that purpose. (R. 184.) Mid West officials saw Langendorf on the same requirements in early February, 1959, but could not meet the delivery requirements of Langendorf. (R. 95.)

Wilson made sketches, had samples made and returned to Langendorf on March 5, 1959 with the Pal-A-Teer, Exhibit 9, which is the container charged by the plaintiffs to infringe Lockwood's second patent. Langendorf placed purchase orders with Banner dated March 5, 1959 for 30,000 Pal-A-Teers and on May 20, 1959 for 20,000 Pal-A-Teers. Deliveries of these quantities were completed in August or September, 1959. Langendorf has used and continues to use said containers in its business.

No further orders of Pal-A-Teers have been received by Banner from Langendorf. (R. 193-194.)

In the fall of 1959, Banner sold 17,000 Pal-A-Teers to Safeway Stores, Incorporated. (R. 195.)

Lockwood, on a visit to Langendorf in April, 1959, saw the Pal-A-Teer (Ex. 9) for the first time; photographed it, obtained a sample and sent both to Mid West. Mid West forwarded the sample to its patent attorney. (R. 96, 97 Ex. M, Answer to Interrogatories, 47 and 48.)

Lockwood's application for the second patent, which related to nesting and tiering by a rotating or shifting manipulation, originally filed on February 6, 1957, was amended on May 29, 1959 to add Claim 20 and on November 18, 1959 to add Claims 21-28 and Letters Patent No. 2,931,535 were issued April 5, 1960. Said patent is referred to herein as the "second" patent or "'535."

On April 25, 1960, this action was instituted in the District Court against Langendorf alone for using the Pal-A-Teer (Ex. 9) charged to be an infringement of Lockwood's '535 patent. On October 4, 1960, Langendorf filed its Answer.

On October 18, 1960, Lockwood and Mid West entered into an agreement with Banner (Ex. 5) for the disposition of the action for infringement pending in the United States District Court in Cleveland growing out of Lockwood's first patent. The design patent infringement action was dismissed with prejudice.

Judgment was entered in the infringement action arising out of the sale by Banner of rocking or tilting type containers prior to July, 1957 providing that Lockwood was the inventor and owner and Mid West the exclusive licensee of the reissue patent; that Banner had no right, title, or interest in the reissue patent; that "United States Patent No. 2,782,936, Re 24,731 was legally issued and

reissued and is valid as to Claims 1, 2, 3, 4, and 5"; that Claims 6 and 7 of the reissue were not at issue and no finding was made with reference to said Claims; that Banner had infringed Claims 1 through 5 of the reissue; further infringement was enjoined and damages of \$2,800.00 were adjudged.

Further, the parties provided in the agreement of October 18, 1960 that Lockwod and Mid West waived their right to assert Claims 6 and 7 of the reissue patent specifically against Langendorf in this action then pending in the District Court, or against Banner or any of its privies for manufacture, sale or use of any Pal-A-Teers, Ex. 9, prior to October 18, 1960 and for any continued use of any said containers after October 18, 1960 which had been made and sold prior to that date. Mid West and Lockwood also waived their right to assert Claims 1 through 5 of the reissue patent against the Pal-A-Teer, Ex. 9.

On January 18, 1961, Banner filed a motion to intervene as a defendant in this action on the basis that it was bound by the provisions of the sales agreement with Langendorf to defend it in any infringement suits and hold Langendorf harmless therefrom, arising out of the sale of the Pal-A-Teers (Ex. E & G). On January 23, 1961, the motion to intervene was granted and Banner filed its Answer. On January 30, 1961, Plaintiffs filed their first amendment to the Complaint to make Banner a party defendant.

On April 4, 1961, the defendants filed their amended Answer to the Complaint as amended and their Counter Claim. The Counter Claim asked for a declaratory judgment that both the first and second Lockwood patents be declared invalid and void, that the defendants had not infringed either patent and that plaintiffs be enjoined from asserting anything to the contrary. The Counter Claim

included a third Lockwood patent, No. 2,940,602, but the plaintiffs, at the trial of the action, stipulated that said patent had not been and would not be asserted against the Pal-A-Teer, Ex. 9, or any other Banner structure they then knew about.

At the time the suit was filed, Banner had offered and sold only two structures which tiered and nested without moving parts, i.e. the one that rocked to nest and tier and which admittedly infringed the first five Claims of Lockwood's first patent and the Pal-A-Teer, Ex. 9, which had been sold to Langendorf and Safeway and which was the subject of plaintiff's Complaint.

In a deposition of Banner's President, Vincent Ryan, and Vice-President, James Wilson, taken by the Plaintiffs in Los Angeles on March 28, 1960, another container which tiered and nested without moving parts was exhibited to the plaintiffs. At the trial, this was introduced as Exhibit O. In the deposition, Wilson testified that Ex. O was never put in production nor shown to anyone with the idea of taking an order, but only for comment (R. 421) and he reaffirmed at the trial that none had been sold or offered for sale after March 28, 1960 (R. 420).

On April 25, 1961, the Defendants filed interrogatories directed to the Plaintiffs in which Nos. 1 and 2 asked the Plaintiffs whether it was their contention that Ex. O infringed the reissue patent and in Interrogatories Nos. 5 and 6 whether the Plaintiff contended that Exhibit O infringed the '535 patent. On May 19, 1961, Plaintiffs filed objections to the said Interrogatories on the ground that Exhibit O had not been commercially produced, sold or used and thus any infringement was moot.

On June 16th, the Court ordered the Plaintiff to answer said Interrogatories. Preserving their rights to object to the pertinency of the Interrogatory to the issues of

the action, the Plaintiffs on July 10th answered that they did not contend that Ex. O infringed the reissue patent but did contend that Ex. O infringed claims 20, 21, 22, 23 and 25 of patent '535.

B. ISSUES IN THE CASE.

1. Trial on the Complaint.

This case was literally tried in two separate parts. The first part was tried on the Complaint as amended and the Answers thereto as amended. Only patent '535 and Ex. 9, the container sold to and used by Langendorf, were at issue. Capacity of the parties, ownership and license rights in the patent and jurisdiction of the Court were admitted or not disputed. The two issues are:

(A) Is '535 a legally issued, valid patent or is it invalid because (a) it involves no patentable novelty, but only an aggregation of old and well-known elements not in a patentable combination, or (b) it was anticipated by the prior patent art?

(B) Does Ex. 9, the form of container used by Langendorf after the issue of '535, infringe any of Claims 19 through 28 of patent '535?

The District Court found that:

(A) '535 was a legally issued, valid patent as to the specific structures disclosed in the patent.

(B) Ex. 9 did not infringe '535 as so construed.

2. The Trial on the Counter Claim.

The second part of this case was tried on the Counter claim of the defendants and the Reply. The issues to be determined were:

(A) Is there a justiciable issue as to whether Exhibit 9 containers infringed the reissue patent when no such

containers were made or sold by Banner or purchased by Langendorf after October 18, 1960 and the Plaintiffs had waived all their rights to assert the infringement of the reissue patent against the defendants for the manufacture and sale of Ex. 9 containers prior to that date?

(B) Is there a justiciable issue as to whether Exhibit O containers infringe patent '535 when (i) said container was never commercially produced nor offered for sale or sold by Banner, and (ii) the only assertion of a claim of infringement by the Plaintiffs was compelled by the Court, over the Plaintiff's objections, in the pretrial interrogatory procedures.

(C) Is the reissue patent which added Claim 7 a legally issued, valid reissue patent or is it invalid because (i) the reissue procedures failed to aver or show error, (ii) the invention claimed in Claim 7 is different from that claimed in the original patent, (iii) the subject matter claimed in the reissue was in public use and on sale in the United States for more than one year prior to the filing of the reissue application.

(D) Does Exhibit 9 container infringe Claim 7 of the reissue patent?

(E) Does Exhibit O container infringe any of Claims 20 through 23 and 25 of patent '535?

The District Court found that:

(A)-(B) Defendants were placed in reasonable apprehension of suit as to all Lockwood's patents and an actual controversy existed with respect thereto and therefore there was a justiciable controversy between the parties with regard to the reissue patent and to Exhibit O.

(C) Claim 7 of reissue patent is invalid because there was no error in the original patent alleged as required by

law for a valid reissue and the invention claimed in Claim 7 is different from the invention in the original patent.

(D) Exhibit 9 does not infringe Claim 7 of the reissue patent.

(E) Exhibit O does not infringe Claims 20 through 23 and 25 of patent 535.

C. THE INVENTION OF LOCKWOOD PATENT NO. 2,931,535.

Essentially the invention of the '535 patent, and as defined in claims 19 and 20 of the patent, involves a receptacle without moving parts, the structure of which permits it, by means of a linear shifting of the receptacle in a horizontal direction, to both tier or nest with other identical receptacles in a vertical stack with like parts vertically in line.

This invention avoids the necessity of a change in position (orientation) of the upper receptacle relative to that of the lower receptacle when moving from a tiered position to a nested position or vice versa.

The structure which accomplishes this novel result, as clearly described in the specification of the '535 patent and in claims 19 and 20 thereof, requires four characteristics.

(a) That each receptacle have support points or portions near the top of the receptacle (called upper support portions) on which an upper receptacle can rest, and support points or portions near the bottom of the receptacle (called lower support portions) by means of which the receptacle can rest upon a lower receptacle, and that the upper support portions must be vertically above the lower support portions. Thus in a tiered position the lower support portions of an upper receptacle rest on the upper

support portions of a lower identical receptacle with the result that all like parts of the receptacles are vertically above one another and the stack of receptacles is vertical.

(b) That the structure of the receptacles must be dimensioned and with its parts so arranged that it will nest with an identical receptacle.

(c) That the structure provide spaces (called clearways) at support portions which will permit the upper receptacle to be lifted to disengage the portions supporting the tier and then shifted sideways horizontally to permit the previously engaged support portions to clear each other and to permit such disengaged lower support portions to immediately enter such spaces or clearways at each upper support portion of a receptacle, each such clearway extending down to the lower support portion vertically underneath the upper one so that all of the lower support points of the upper receptacle may move downwardly to a nested position in the lower receptacle. Then in the nested position the claims recite a vertical clearway directly above the lower support point of the upper receptacle up to the upper support of the lower receptacle. These are the clearways through which the nesting action just took place.

(d) In nesting position all like parts of the identical receptacles are vertically above one another and the stack of nested receptacles is vertical.

The form taken by a structure incorporating these characteristics (called mechanical means) can be many and varied so that the appearance of any particular container is not determinative of its use of the invention. Usually the appearance of the structure of the container grows out of its proposed use.

Thus Exhibit 8 made by plaintiff, Mid-West, which fol-

lows patent drawings Figs. 37 and 38, was for the purpose of holding a number of smaller packages, such as ice cream cartons or potato chip bags (R. 57) and so required a completely enclosed container. However, Exhibit 9, made and used by the defendants was for handling packaged cakes, rolls, or bread which required only partial enclosure in order to retain the contents in place. Yet both containers incorporated and used the mechanical means of the '535 invention in the same combination, in the same manner and with the same result.

Plaintiffs believe that the District Court was misled by the completely dissimilar appearance of the two Exhibits 8 and 9 and thus failed to appreciate that the significance of the invention disclosed in patent '535 is in the combination of mechanical means, that is, upper and lower support portions vertically in line, dimensions of like containers so they would nest, and clearways which permitted the support points to be disengaged and cleared by sidewise horizontal movement and dropped so that all support points and like parts were in vertical alignment. This failure to grasp the nature of the invention led the District Court into the error of finding that the '535 patent was limited to the particular physical structure of the container exemplified by Exhibit 8 and, therefore, that Exhibit 9 did not infringe and that prior patents were not distinguishable.

The use of receptacles which nest and tier is not new, but Lockwood's method of accomplishing this result is novel. Plaintiffs' witness Glezen testified (R. 42) that at the time of the invention of the '535 patent, it was common to use either throw-over bails to accomplish the same result or to use differently shaped parts at opposite ends of a receptacle, which parts would nest in one orientation of

two receptacles and which could be used for tiering only by a 180° turn of the upper receptacle end for end to obtain interfering tiering support portions on the two receptacles. This 180° oriented type of the prior art was illustrated by the miniature models Exhibit 2 (R. 43). The Faulkner patent No. 2,252,964, relied upon by the defendants, shows the throw-over bail type of construction as indicated at 11 on the sheet 1 of the patent (R. 204) and on sheet 2 of the patent are shown devices wherein in moving from tiering to nesting position the upper receptacle must be turned 180° end for end (R. 205).

To illustrate the structure of the patented receptacles as defined in claims 19 and 20 of the '535 patent, plaintiffs introduced Exhibit 8 constructed according to Figs. 35 through 38 of the '535 patent (R. 55). Referring to Plate I attached hereto, each receptacle has a number of upper support points marked X which are vertically above lower support points Y. In the tiering position of Fig. 37, each lower support portion Y of the upper receptacle rests upon one of the upper support portions X of the lower receptacle, and like parts of both receptacles are in vertical registration one above the other. To move from this position of Fig. 37 to the nested position of Fig. 38, the upper receptacle is lifted slightly until each lower support portion Y of the upper receptacle is high enough to pass over the point 78a of the associated wire of the lower receptacle. This movement of the upper receptacle is toward the left to the position shown in dot-dash lines in Fig. 38. After this, the upper receptacle is passed downwardly into the lower receptacle, each of the slanting rods 78' of the upper receptacle passing downwardly in the clearway between the parallel rods 78 of the lower receptacle. In the final nested position shown in Fig. 38 in full lines the like parts of both

receptacles are in vertical registration one above the other. This manipulation and the designation of the upper and lower support portions and of the clearways was recited and demonstrated by the witness Townsend (R. 103-109).

D. THE INVENTION OF LOCKWOOD REISSUE 24,731.

This patent is a reissue of patent No. 2,782,936. It discloses receptacles which are tierable and nestable vertically in line without moving parts. The bottom is longer than the top and a single bar extends across each end of the receptacle at the top to hold the bottom of a like receptacle when two of them are tiered. The crossbars are the upper tiering support members and the end extensions of the bottom are the lower tiering support members. An upper receptacle is nested in a lower one by a tilting or rocking manipulation whereby one bottom end of the upper receptacle is passed through a clearway beneath one crossbar of the lower receptacle, which then enables the other bottom end of the upper receptacle to pass under the crossbar at the other end of the upper receptacle. The five claims of the original patent were specific to such tilting or rocking action to cause nesting. The reissue 24,731 patent made no changes in the original except to add claims 6 and 7. Claim 6 relates to the rocking or tilting action and claim 7 defines the structure in generic terms which accomplishes the same results by "manipulation" of the upper receptacle. Only claim 7 is involved in this lawsuit.

E. DEFENDANTS' ACCUSED DEVICE.

The accused device, introduced as Exhibit 9, and shown in Plates II and IIA hereof, is generally rectangular, has a bottom made up of a plurality of parallel wires running lengthwise, has parallel sides extending along the longer sides of the rectangle, each side having six slanting

wires connected by a top wire and by an intermediate wire running the full length, and has no end walls except a short projection upwardly from the bottom to keep articles from slipping out. Upper tiering supports are four up-standing hook-like projections near the four corners and formed by the top wire being bent inwardly and upwardly. Bottom tiering supports are four wire loops extending laterally from the bottom, each loop vertically below one of the hook-like projections. All of the parts are welded together.

III. SPECIFICATIONS OF ERROR.

1. The Court erred in finding that the Claims of the '535 patent must be strictly and narrowly construed and as so construed are limited to structures where the bottom of the top receptacle must lie within the top of the bottom receptacle in both nested and tiered positions, and clearways generally extending vertically between the lower support points of an upper receptacle and the upper support points of a lower receptacle when the receptacles are nested.

2. The Court erred in finding that Exhibit 9 did not infringe the Claims of patent '535.

3. The Court erred in admitting Exhibit K as evidence.

4. The Court erred in finding that there was a justiciable issue between the parties as to the infringement of the reissue patent by Exhibit 9.

5. The Court erred in finding that there was a justiciable issue between the parties as to the infringement of patent '535 by Exhibit O.

6. The Court erred in finding and entering judgment that Claim 7 of the reissue patent is invalid.

7. The Court erred in finding that Exhibit 9 did not infringe Claim 7 of the reissue patent.

8. The Court erred in finding that Exhibit O did not infringe patent '535.

9. The Court erred in entering judgment that defendants had not infringed patent '535 nor the reissue patent and enjoining plaintiffs from asserting that Defendant's Exhibits 9 or O, or either of them, infringed either patent '535 or the reissue or from asserting that Claim 7 of the reissue patent was valid.

10. The Court erred in entering judgment that Plaintiffs should take nothing by their Complaint as amended and should be responsible for the costs of the Defendants.

IV. SUMMARY OF ARGUMENT.

Point 1.

No justiciable issue as to Ex. 9 infringing re-issue patent, nor as to Ex. O infringing '535 patent.

1. The District Court erred in refusing to dismiss the counter claim for lack of a justiciable issue between the parties as to Exhibit 9 and Claim 7 of the reissue patent and Exhibit O as to Claims 20, 21, 22, 23, and 25 of the '535 patent.

(a) All rights of the plaintiffs to assert Claim 7 of the reissue patent receptacles of the Exhibit 9 structure manufactured, used and sold to the time of trial had been waived and Exhibit 9 was no longer being offered for sale nor orders received or solicited nor had plaintiffs voluntarily asserted its patent rights against defendants or their customers since October 18, 1960, the date of the waiver.

(b) Exhibit O was an experimental model of a container, never sold or offered for sale or put in produc-

tion and plaintiffs had not voluntarily asserted any patent rights as to Exhibit O to Banner.

(c) Under the Federal Declaratory Judgment Act, 28 USCA 2201, an "actual controversy" required for a cause of action for declaratory relief arises only when a patentee voluntarily asserts a claim of infringement against the alleged infringer.

(d) The plaintiffs' assertions of infringement against Exhibit 9 and Exhibit O compelled by the District Court over plaintiffs' objection, in answering defendant's interrogatories are not voluntary within the rule set out in (c) above and cannot serve to support the defendant's counter claim.

(e) The conduct of the plaintiffs in protecting their patent rights against previous infringements by the defendant, Banner, does not give rise to an implied continuing claim of infringement of Claim 7 of the reissue patent by Exhibit 9 and of the enumerated Claims of '535 by Exhibit O which creates an actual controversy available for declaratory relief.

Point 2.

Exhibit 9 infringes claims 19 and 20 of the '535 patent. This is true because Exhibit 9 produces the same result in the same way as defined in claims 19 and 20. The accused device has upper tiering support points vertically above lower tiering support points and the clearways which permit a slight shifting laterally from a tiered position after which an upper receptacle moves down to nested position in the lower receptacle, the dimensions of the two receptacles permitting this.

Point 3.

The '535 patent is not anticipated by the prior Faulkner patent 2,252,964. This is because Faulkner does not have upper tiering support points vertically above lower tiering support points and does not have the clearways which permit a slight lateral shifting of an upper receptacle from tiering position so as to clear the support points and permit the upper receptacle to move down to nesting position in the lower receptacle. Furthermore, the Faulkner devices do not tier with the like parts of two receptacles in vertical alignment.

Point 4.

The '535 patent is not anticipated by prior Blom patent 2,684,766. This is because the Blom patent does not show upper tiering support points vertically above lower tiering support points and the clearways called for in claims 19 and 20 of the '535 patent.

Point 5.

Exhibit 9 infringes claims 21 to 28 of the '535 patent. With respect to these claims the court followed its finding of non-infringement of claim 20 upon which these other claims were dependent.

Point 6.

Exhibit O infringes claims 20 to 23 and 25 of the '535 patent. This is because Exhibit O is like Exhibit 9 in every respect except that the parts of the receptacles are arranged to compel nesting very slightly out of line but with every fourth receptacle directly in vertical alignment.

Point 7.

Exhibit 9 infringes claim 7 of Reissue 24,731. This is because Exhibit 9 produces the same results and in the same way as defined in claim 7 of the reissue patent. Exhibit 9 has upper tiering support points vertically above lower tiering support points and the clearways permitting an upper receptacle to nest downwardly in a lower receptacle only by manipulation as called for in claim 7.

Point 8.

Claim 7 of Reissue 24,731 is valid because applicant in applying for the reissue complied with Section 251 of Title 35 U. S. C. A., because the invention of claim 7 is the same invention as in the parent patent only stated in generic instead of specific terms, and because the new claims should not be held invalid against subsequent infringers merely because, for a year prior to the application for a reissue patent, the invented device had been sold under the protection of the original patent.

V. ARGUMENT.**POINT 1.**

NO JUSTICIABLE ISSUE AS TO EX. 9 INFRINGING RE-ISSUE PATENT, NOR AS TO EX. O INFRINGING '535 PATENT.

The complaint and the answer thereto, both as amended, raised issues as to the validity of the '535 patent and the infringement of '535 by Exhibit 9, the container manufactured by Banner and sold to Langendorf and Safeway (R. 193-195). Under the counter claim for a declaratory judgment the defendants raised the additional issues that the reissue patent was invalid, that Exhibit 9 did not infringe Claim 7 of the reissue patent, that another container made by Banner, Exhibit O, did not infringe claims 20, 21, 22, 23 and 25 of the 535 patent.

On October 18, 1960, plaintiffs had waived all their rights to assert claims 6 and 7 of the reissue patent against Banner and its privies for the manufacture, use or sale of Exhibit 9 containers prior to October 18, 1960, and for the continued use after October 18, 1960 of any such containers manufactured and sold before October 18, 1960 (Ex. 5). The plaintiffs' rights to assert the reissue patent against the manufacture, use and sale of the 50,000 Exhibit 9 containers sold to Langendorf had been completely waived. These were the containers which furnished the basis of the complaint. In addition, the 17,000 Exhibit 9 containers sold by Banner to Safeway Stores prior to October 18, 1960 were included in the plaintiffs' waiver (R. 195).

There were no containers of the Exhibit 9 structure made and sold after October 18, 1960, and the previous arrangements made for the sale of such containers through Echo Products Company of Chicago had been terminated. (R. 401, 412.) No further orders for Exhibit 9 structure had been solicited or received, and no customers had been threatened by plaintiff with suits for infringement of the reissue patent after the date of the waiver, October 18, 1960.

The sole and only assertion by the plaintiffs after October 18, 1960 that the structure of Exhibit 9 infringed Claim 7 of the reissue patent was made after the lower Court compelled the answer of the defendants' interrogatory Nos. 3 and 4 over plaintiffs' objection.

At the time the complaint was filed in this action and the original answers had been filed by the defendants, Banner had made and sold only two containers with structures which permitted nesting and tiering without moving parts. The first employed a rocking or tilting motion and was confessed by Banner to infringe Claims 1 through 5 of Lockwood reissue patent in the suit in the District Court in

Cleveland. The second container is Exhibit 9, the subject of this suit.

In a deposition hearing on March 28, 1960, another container which tiered and nested without moving parts was exhibited to the plaintiffs by the defendants. At the trial, this was introduced as Exhibit O. It had not at that time nor at the time of the trial been sold or offered for sale nor put in production (R. 420, 421). Plaintiffs were not asked for, nor did they tender, any assertion that Exhibit O infringed any of Lockwood's patents until they were compelled by the lower Court to do so, over their objection, by answering defendants' interrogatories Nos. 5 & 6.

Further, at a deposition of Warren Lockwood held in this matter on August 8, 1961, still another structure of a container which tiered and nested without moving parts was exhibited by the defendants to plaintiffs and called Exhibit E of said deposition. Again, the only assertion by plaintiffs that said container infringed patent '535 and the reissue patent was compelled over plaintiffs' objections, by order of the lower Court to answer to defendants' interrogatory No. 38 through 41. Although the evidence disclosed that 5,000 of these containers had been sold between August 8, 1961 and the time of trial (R. 418) the defendants *did not* present said container for declaration by the Court of its infringement of the patents asserted.

The plaintiffs' motion to dismiss the counter claim for lack of a justiciable issue made prior to the introduction of any evidence was overruled after a proceeding under Rule 42. The motion was reviewed at the close of the evidence and again overruled.

35 USCA Sec. 271 (a) defines an infringement of a patent:

"Except as otherwise provided in this title, whoever without authority makes, uses or sells any pat-

ented invention, within the United States during the term of the patent therefor, infringes the patent.”

35 USCA Sec. 281 provides the remedy for infringement.

“A patentee shall have remedy by civil action for infringement of his patent.”

Section 282 provides that invalidity of the patent or any claim thereof and non-infringement are defenses to an action of infringement as well as other violations of the provisions of Title 35.

The necessity of the actual manufacture or use or sale of the infringing product by the infringer in order to maintain an infringement action is clearly stated in numerous cases. The following cases have been selected because the facts are similar to those in this case.

In *Dugan v. Lear Avia*, 55 F. Supp. 223, aff. 156 F. 2d 29 the Court said at page 229:

“The accused devices are represented by Exhibits 7, 8, 9 and 10. Exhibit 9 can be eliminated from consideration for it affirmatively appeared, without contradiction by the plaintiffs, that defendant built that device only experimentally and that it has neither manufactured it for sale nor sold any. *Bonsach Machine Co. v. Underwood*, 73 F. 206, 211.”

The Court in *New Wrinkle, Inc. v. Fritz*, 30 F. Supp. 89, in dealing with the question of jurisdiction of the court in infringement action said at page 91:

“The charge here is infringement. There can be infringement only by the making, selling or using of the infringing product. Sale means the making of the agreement binding the parties * * *. Displaying samples and demonstrating their use are merely incidents in the solicitation of the sale, and in no way affect the place of sale. The statute requires more than that.”

In *Marlott v. Mergenthaler Linotype Co.*, 70 F. Supp. 426, the Court said at page 431:

“We have found no case which holds that the mere display of the infringing article constitutes an act of infringement.”

In *Beidler v. Photostat Corp.*, 10 F. Supp. 628, affirmed 81 F. (2d) 1015, the Court held:

“Syl. 1.—Where the defendant entirely ceased manufacture, use and sale of infringing machine after grant of plaintiffs patent and there was no threatened or contemplated infringement, defendant’s mere possession of a dismantled machine which was reassembled shortly before trial and brought into Court in operative condition to be used as an exhibit, but which was not used or exhibited except for purposes of such litigation, held not to entitle plaintiff to injunction against infringement.

“2. There has been no invasion or threatened invasion of patentee’s monopoly after the grant, defendant’s possession of a device as a model does not constitute actual or threatened infringement in absence of proof that machine is held for purposes of profit in violation of patentee’s exclusive right to make, use, and sell the patented invention.”

The declaratory judgment procedure has been widely used in patent matters pursuant to 28 USCA Section 2201 which provides:

“In a case of actual controversy within its jurisdiction, except with respect to Federal taxes, any court of the United States, upon the filing of an appropriate pleading, may declare the rights and other legal relations of any interested party seeking such declaration whether or not further relief is or could be sought. Any such declaration shall have the force and effect of a final judgment or decree and shall be reviewable as such.”

In the absence of the requirements of proof of the fact of manufacture or sale or use of the article accused of infringing the patent, a very considerable body of cases have been litigated to determine when there is an "actual controversy" involving the validity of a patent or its infringement *before* either the article is manufactured, used or sold or before an infringement suit is brought by the patentee. The Court in *Tremond Co. v. Schering Corporation*, 122 F. 2d 702, states the prevailing view that an "actual controversy" within the meaning of the Federal Declaratory Judgment Act does not exist between the patentee and the alleged infringer until the patentee makes some claim that his patent is being infringed. In holding that notifying plaintiff's customers directly and by placing advertisements in trade journals that a drug imported and sold by plaintiff violated defendant's patent constituted a claim of infringement against the plaintiff, the Court quoted with approval language on page 807 of *Borchard's Declaratory Judgments* (2 ed.) in part as follows:

"And yet, it seems best to limit declaratory relief for the infringer to cases in which an adversary claim has been made against him, though it may, it is believed, apply to an article not yet manufactured but only about to be manufactured. This requirement, present in practically all the adjudicated cases, refutes the fear that patentees might be harassed by prospective infringers and be obliged continually to defend their patents. *The fact that a patentee's claim of infringement is a condition precedent of this type of action places the matter of adjudication of the patent within control of the patentee, for, if he wishes to avoid adjudication, he can refrain from making charges of infringement. But having made the charge, he then exposes himself to adjudication.* In other words, the mere existence of the patent is not a cloud on title, and enabling any apprehensive manufacturer

to remove it by suit. It requires an assertion of right under the patent to place the alleged infringer in gear to join issue and challenge the title." (Emphasis is the Court's.)

In the present matter, it is clear that so far as the re-issue patent is concerned, Banner has neither manufactured, used nor sold any Exhibit 9 structures to which plaintiffs have not specifically waived their rights. The arrangement for selling this receptacle was terminated and it was not being offered for sale. No customers or prospective customers of Banner had been threatened or warned of plaintiffs' reissue patent rights since the withdrawal of Exhibit 9 from the market and since plaintiffs' waiver of its rights to those receptacles previously sold. In the words of the first syllabus of *Beidler v. Photostat Corp.*, 10 F. Supp. 628, "There has been no invasion or threatened invasion of the patentee's monopoly" which necessitated, in plaintiffs' opinion, any adversary claim being made against Banner by the plaintiffs.

Exhibit O was one form of a series of developmental containers which had not been sold nor displayed for sale nor put in production. No request was made of plaintiffs by the defendants, either directly or indirectly, as to their position as an infringement of their patents by Exhibit O should it be offered for sale.

The sole and only expression of the claim of the plaintiffs that Exhibit 9 violated the Claim 7 of reissue patent made after October 18, 1960, and that Exhibit O violated certain claims of '535 patent were compelled by the District Court in answering interrogatories.

The procedure used in this case of filing a declaratory judgment action with allegations not subject to demurrer even though at that time patentee has not charged an infringement of his patent then by pretrial discovery pro-

cedures compelling the patentee to state its position on the infringement of its patent and then using that disclosure of position as the basis for his "controversy" with the patentee, aborts the protection afforded by the rule stated in the *Tremond* case, 122 F. 2d 702. There the Court said that "the fact that a patentee's claim of infringement is a condition precedent to this type of action (declaratory judgment) places the matter of adjudication of the patent within the control of the patentee, *for, if he wishes to avoid adjudication, he can refrain from making charges of infringement.*"

If the patentee is compelled by the courts to make a charge of infringement which is then used as the basis for the declaratory judgment action, a patentee is fair game for harassment by any and all prospective infringers.

Banner's position in the trial court was that the plaintiffs' continued vigilance in protecting their patent rights through suits and letters to Banner's customers constituted a continuing threat of infringement action against any of their developments. This overlooks the fact that whatever action the plaintiffs have taken in protection of their rights have been made necessary by Banner's activities.

When the plaintiffs marketed the first nesting, tiering container in the baking field of the type herein involved, Banner filed and lost a suit claiming title to the patent or a shop right therein. It also made practically a Chinese copy of the plaintiff's container which necessitated a design patent infringement suit. Then Banner changed the exterior appearance of their container and sold a container using the first patent. This required the successful Cleveland infringement action. Banner then designed Exhibit 9 to avoid the first patent and sold it. This fell within the '535 patent and this suit was filed. Banner then retired

from the field of selling its existing containers, but kept trying to design around the plaintiffs' patent claims. This resulted in the construction of Exhibit O and Exhibit E of the deposition of Warren Lockwood of August 8, 1961. Exhibit O which has not been sold or offered for sale is a subject of this counter claim. Exhibit E of Lockwood's deposition, which was introduced into this case by means of defendants' interrogatories Nos. 38, 39, 40, 41, 42, and 43 and in the same manner as Exhibit O *was not* introduced at the trial for a declaration as to its infringement of plaintiffs' patents (in spite of the fact that *5,000 units were sold before this trial by the defendants*).

Can an infringer whose activity has compelled a patentee to take action to protect his patents then use the activity he induced as the basis for claiming a continuing threat of infringement by the patentee as to any new development made by it? Several courts have said no.

In *Chicago Pneumatic Tool Co. v. Hughes Tool Co.*, 61 F. Supp. 767, aff. 156 Fed. 981, the plaintiff sought a declaratory judgment that none of the defendant's eleven patents enumerated in the complaint were valid or "in the alternative, that defendant be required to file a statement in this proceeding of any patents which it intends to assert have been, during the past six years, infringed by plaintiff's devices." The defendant's conduct which plaintiff urged indicates an "actual controversy" was (1) assertions of the defendant ten and six years before that it considered devices then made by plaintiff an infringement of three of the patents, (2) letters between lawyers for the parties in attempting to settle a then pending infringement action that one of the difficulties of settling the then pending action "arises from the other patents owned by Hughes Tool Company * * * which are contended * * * to have been infringed by Chicago Pneumatic Tool Com-

pany," and (3) that defendant's contentions made in another case against another user were of such scope that plaintiff feared that such claims would be asserted against it.

The court said at page 772:

"Settlement of the difference of opinion on the range of a decree rendered by another court as it may bear on possible future controversies between the same parties calls for an advisory opinion. It forms no structure for declaratory relief. The 'omnibus charge,' an incident in the Oklahoma proceeding, * * * was nothing more than traditional lawyer's chess. The ten-year old infringement notice should rest in peace. The day for justiciable resurrection has long since past. Here in the present, no charge * * * that what the plaintiffs now make or sell has been called into question by the defendants with respect to any of its patents."

And in *Research Electronics and Devices Co., Inc. v. Neptune Meter Company*, 156 F. Supp. 484, Aff. 264 F. 2d 246, the Court held:

"Syl. 2. Where plaintiff wrote letter to defendant advising him of alleged infringement of designated patents and stated there were a number of "other patents and pending patent applications" which may be infringed by the defendant, letter was not an omnibus charge of infringing all of plaintiff's patents so as to create a justiciable controversy which would be resolved by defendant's counter claim for a declaratory judgment decreeing non-infringement."

Banner's position that this counter claim will avoid a multiplicity of suits in determining the validity of the patents and the infringement of their structures was emasculated by its action in refusing to submit its latest structure, deposition Exhibit E, as a part of the Counter claim. This

refusal makes another suit necessary should the plaintiffs determine to press the infringement arising out of said sale of 5,000 units of deposition Exhibit E.

What the defendants wanted and erroneously received in the lower court, was an advisory opinion as to whether it can sell Exhibits 9 and O free of the reissue patent and '535 if it should desire to do so in the future.

The plaintiffs' motions to dismiss the counter claim were erroneously overruled.

POINT 2.

EXHIBIT 9 INFRINGES CLAIMS 19 AND 20 OF THE '535 PATENT.

The infringing receptacle was introduced in evidence as Exhibit 9 (R. 60). Attached hereto as Plate II are line drawings of Exhibit 9 to illustrate the following remarks. The upper support points, marked X, are upwardly turned hooks formed of a piece of wire bent inwardly from the top wire of the receptacle. The lower support portions, marked Y, are wire loops rigid with the bottom of the receptacle. Each lower support portion Y is vertically below its associated upper support portion X. It should be understood that in the tiering position of two like receptacles, each lower support portion Y is looped over and rests upon a corresponding upper support portion X as shown by fragmentary parts in Position 1. In this tiering relationship of two like receptacles all like parts of the two receptacles are in vertical registration one above the other. To move an upper receptacle of Exhibit 9 from tiered position to nested position, the upper receptacle is first lifted vertically upward until the lower support portion Y' (of an upper receptacle) clears its associated upper support portion X (of a lower receptacle) and then this lower support portion Y' is moved in either direction

laterally, a position where the portion Y' is moved to the left of portion X being indicated at Position 2 of Plate II. There is then a clearway permitting each portion Y' to be moved downwardly and back to a position vertically under the upper support portion X to a nesting position where each lower support portion Y' (of the upper receptacle) rests on top of a nesting limit bar 10 (of the lower receptacle), such nesting position being shown in Position 3. Here again, in nesting position of two like receptacles all like parts of the two receptacles are in vertical registration one above the other.

Referring to plaintiffs' patent structure, Exhibit 8, (Plate I) and defendants' receptacle claimed to infringe, Exhibit 9, (Plate II), the District Court found in Finding of Fact 33 that "patent '535 accomplished both tiering and nesting like parts over like parts, by a particular structure not shown in the prior art." The finding went on to say that defendants' receptacles, Exhibit 9, do not use such structure or the substantial equivalent thereof. Looking at Plate I and Plate II attached hereto, it is obvious that both plaintiffs' and defendants' structures have "upper support portions being vertically above said lower support portions." It is also obvious that both plaintiffs' and defendants' structures show "parts of a receptacle permitting nesting and tiering of two like receptacles with their like parts in vertical registration one above the other." Both of the above quotations are from claim 19 of the '535 patent.

In what respects then did the District Court find that defendants' receptacles do not use plaintiffs' structure or the substantial equivalent thereof? One reason was the "dimensions" clause of claims 19 and 20 of the patent in suit and the other was the "clearways" clause of the same claims. These will be taken up in that order.

The "Dimensions" Clause.

Claim 19 of the '535 patent describes the structure of a receptacle "adapted for tiering and nesting with other like receptacles" and after setting out the requirements as to the clearway between the upper and lower support portions in a *nested* position uses the following language: "the dimensions of the lower part of one tray lying inside the dimensions of the upper part of a like tray * * *."

Claim 20 describes the structure of the receptacle "adapted for tiering and nesting with other like receptacles," and sets out the requirements of the upper and lower support points, sides and bottom, then says: "the dimensions of the upper and lower parts of said receptacle permitting the lower part of an upper receptacle to enter vertically downward into the upper part of a lower like receptacle."

The plaintiffs contend that this language clearly defines the structure itself which is required to have a top of such "dimension" and a bottom of such "dimension" that the top receptacle will nest inside of the lower receptacle.

The District Court, however, (ignoring the word "dimensions") held that this language meant that the bottom of the upper receptacle must be inside the top of the lower receptacle when the receptacles were in *tiered position* and *before* the shifting took place. The Court construed this language as defining a part of the act of shifting the top receptacle into a nesting position rather than as defining the structure of the receptacle. Otherwise stated, the Court treated the "dimensions" language as defining the *position* not the *structure* of the receptacle.

The Court based its erroneous conclusion on two points. First, on the action of the Patent Office Examiner which resulted in the inclusion of the "dimensions"

language in claim 19, and second, on the method of the utilization of the invention in Exhibit 8, representing Figures 37 and 38 of the '535 patent.

In Findings of Fact 15 through 18, the District Court arrived at conclusions which are clearly not in accord with the evidence presented. In Finding of Fact 15, the Court said: "This limitation (the dimensions clause) was added by the applicant in response to a rejection by the Patent Office Examiner, in which the claim was rejected on an earlier Lockwood patent 2,782,936." In Finding of Fact 18 this language occurs: "Since this quoted language was inserted to distinguish over the prior art nesting receptacles of '936, it must be read with the receptacles tiered, for otherwise it would not so distinguish."

The file wrapper and contents of patent No. 2,931,535 was introduced in evidence as Exhibit 10. In paper No. 3 of this Exhibit, in an Office Action dated May 14, 1957, the Patent Office Examiner made this statement: "Claims 1, 9, 11, 13 and 19 are rejected as unpatentable over the patent to Lockwood. In Lockwood (2,782,936) attention is called to Figs. 9 to 11 on which these claims read in all material respects. Insofar as the *structure positively set forth in the claim is concerned*, it is a matter of indifference whether the device is rotated slightly on a horizontal or a vertical axis."

In Paper No. 4, an amendment filed by the applicant Lockwood November 12, 1957, the above quoted "dimensions" clause was added to claim 19 and this paragraph occurs in the remarks accompanying this amendment.

"Generic claims 11, 13 and 19 * * * have been amended so as to positively set forth this *structure* distinguishing over Lockwood 2,782,936. These claims now clearly distinguish *structurally* over the Lock-

wood patent by reciting that the bottom of one tray has dimensions which fit inside of the upper portion of a like tray. This is obviously impossible in Lockwood Figs. 9 to 11 cited by the Examiner."

Note that in the above exchange of papers between the Patent Office and the applicant, the Patent Office required *structural* distinctions over the prior Lockwood '936 patent, and applicant then added such *structural* definition and recited that he was now clearly distinguishing *structurally* over the Lockwood patent. The witness Townsend explained this using Exhibit 1 (R. 152, 153) by demonstrating that in the Lakewood '936 patent the bottom of the tray or receptacle was longer than the top and, therefore, the dimensions of the bottom of one tray would not lie within the dimensions of the top of another tray.

Whereas the bottom of the upper receptacle of the structure required by the '535 patent must be of such dimensions that it will fit inside the top of the lower receptacle.

The "Memorandum of Opinion" of the lower Court indicates that the Court considered only the utilization of the invention demonstrated in Exhibit 8 (Figures 37 and 38 of the patent '535) and failed to consider other patent drawings in dealing with the construction of the "dimensions" language. For instance, in the "Memorandum of Opinion" at page 8 occurs this language:

"Exhibit 9, the accused, is so constructed that, when tiered, the *lower part* of an upper tray does not lie inside the dimensions of the upper part of a like lower tray."

And again in the next paragraph:

"By way of contrast Exhibit 8, the patent model, is so constructed that, when tiered, the *lower part* of an upper Exhibit 8 type tray does lie literally inside the dimensions of the upper part of a like lower tray."

It will be noted in the above two quotations that in each case the Court did not compare the "dimensions" of the lower part of one tray with the "dimensions" of the upper part of another tray but rather he completely forgot the word "dimensions" when referring to the lower part of an upper tray.

In addition to Figures 37 and 38 of patent '535 on which Exhibit 8 was based, there were figures of seven (7) additional forms of structures (called embodiments) which illustrated the use of the inventions claimed in the patent. Both the plaintiffs' and defendants' patent expert witnesses testified that claims 19 and 20 were general or inclusive claims (generic) as opposed to specific claims (Robbins R. 252; Townsend R. 138). Townsend, plaintiffs' witness, testified (R. 138) that the generic claims 19 and 20 applied to (read on) all of the embodiments set out in the '535 patent. Robbins, defendants' witness, said claim 20 read on all the embodiments of the '535 patent (R. 252). Townsend testified about these embodiments as follows (R. 637):

"Q. Mr. Townsend, during the recess have you had opportunity to examine the drawings of the '535 patent?

A. Yes, I have.

Q. Did you find in there any forms, any embodiments in the '535 patent wherein two receptacles when stacked would not have the upper receptacle extending down into the lower receptacle?

A. I found that there were four of the eight embodiments of the Lockwood '535 patent show receptacles when stacked would have no substantial part or any part of the bottom of the top receptacle nested within the upper portion of the lower receptacle, and these embodiments would be those shown in Figs. 1-2, 3 and 4, 20-27, and 28-34."

Examination of these four embodiments conclusively establishes that the lower Court's construction of the "dimensions" clause is erroneous since none of these four structures *in a tiered position* have a substantial portion of the bottom of the upper receptacle within the upper portion of the lower receptacle.

Examination of Figure 29 attached as Plate V and Exhibit 9, the accused receptacle, pictures of which in tiered position are attached as Plate IIA, discloses that the position of these receptacles in a tiered position are as nearly identical as it is possible to get and establish conclusively that Exhibit 9 structure falls within the "dimensions" language of claims 19 and 20.

The "Clearways" Clause of Claims 19 and 20 of the '535 Patent.

Claim 19 of the '535 patent contains the clause "there being a generally vertically extending clearway from directly above each *lower point* of support of an *upper receptacle* extending upwardly to the *upper points* of support of a *lower receptacle* when two like receptacles are nested" (emphasis added). Plate II, attached hereto, shows line drawings of Exhibit 9, the accused receptacle of the defendants. The quoted clause from claim 19 refers to the nested position of two like receptacles. In Plate II at Position 3 the lower support point of an upper receptacle is indicated at Y' resting on the bar 10 of the lower receptacle. The upper point of support of the lower receptacle is indicated at X. The "clearway" defined in the above quoted clause from claim 19 is indicated by the dimension Z in Plate II. It was the defendants' contention (R. 328 to 333) that this language meant that the receptacles must be nested to the full depth permitted by the

structure of the particular receptacle and that bar 10 placed in Exhibit 9 to limit the depth of nesting into the lower receptacle interrupted the vertical clearway required by the above quoted language. The lower Court adopted this contention in Finding 19.

This is obviously in error because, as Plate II so clearly demonstrates and as Townsend testified (R. 566), the required clearway is between the *lower* support point of the *upper* receptacle which *rests on top of bar 10* and the upper support point of the lower receptacle. Nothing interrupts this space.

The "clearways" clause in claim 20 reads: "and in shifted position there being a clearway from the level of each of said upper tiering support portions down to that level in the receptacle occupied by the lower tiering support portions of a like receptacle when two like receptacles are nested." It is clear from an examination of Exhibit 9 that in the shifted position indicated at Y', Position 2 in Plate II, there is a clearway down to that level shown with Y' at Position 3, resting on bar 10, "to that level in the receptacle occupied by the lower tiering support portions Y' of a like receptacle when two like receptacles are nested."

Mr. Glezen testified that the receptacles of Exhibit 8 nested in groups whereas Exhibit 11 nested continuously (R. 649, 650). Both of these Exhibits were made according to the teachings of the '535 patent. The purpose of the bar 10 in Exhibit 9 is to hold the bottom of one receptacle above the other receptacle so that continuous nesting is possible rather than having the bottom of one receptacle nest tightly against the one below it which eventually is self-terminating when a particular "group" is nested together. This was testified by defendants' witness Wilson (R. 642-644). The defendants themselves defined the

“nested” position of two receptacles of the Exhibit 9 type when Mr. Wilson, who designed the Exhibit 9 receptacle, testified (R. 193) that the sixth photo in the series introduced as Exhibit F shows the two Exhibit 9 receptacles in “fully nested position.”

For the above reasons, it is obvious that Finding of Fact 19 is erroneous and that Exhibit 9 does have the “clearways” defined in claims 19 and 20 of the '535 patent.

POINT 3.

THE '535 PATENT IS NOT ANTICIPATED BY PRIOR FAULKNER PATENT 2,252,964.

The District Court erred in Finding of Fact 11 and Conclusion of Law 4 when he stated that the main elements of the '535 patent are found in the prior art.

Also, Finding of Fact 25 reads as follows:

“The prior art Faulkner patent 2,252,964 teaches tierable, nestable receptacles without moving parts in which movement from tiered to nested position is effected by a rotational manipulation, without tilting, of the upper receptacle above the lower receptacle, to align it with clearways that make nesting possible. In Faulkner, tiering as well as nesting produces exact vertical stacking or alignment. Faulkner was not cited by the Patent Office Examiner during the prosecution of the '535 patent.”

This Faulkner structure was exemplified by Exhibit I which was defined (R. 206) as being constructed according to the drawings on sheet 2 of the Faulkner patent. (Plate III attached hereto). This structure operates by rotating the top container 180° or end for end in order to engage or disengage the upper and lower support points between tiering and nesting.

No weight should be attached to the failure of the Patent Office Examiner to cite Faulkner against the '535

patent. He did cite Jarund 2,742,181 (as printed at the end of the '535 patent). Jarund is bound in the book of patents Exhibit A. Jarund employs the same principles of nesting and tiering as Faulkner using a 30° turn where Faulkner uses a 180° turn.

The District Court erred in evaluating the Faulkner patent as prior art because essential structure defined in claim 19 of the '535 patent is not found in Faulkner. Faulkner does not have the upper support points vertically above the lower support points nor vertically extending clearways extending between the support points; and the like parts of each Faulkner receptacle are *not* in vertical registration one above the other in tiered position.

Claim 19 defines upper support portions and lower support portions in a single receptacle and says "said upper support portions being vertically above said lower support portions." On Plate III attached hereto the upper support points of Faulkner are marked X and the lower support points are marked Y. The witness Robbins was asked (R. 282) to measure from the vertical corner of a receptacle respectively to the nearest support point X or Y. He found one of these support points $3\frac{1}{4}$ " from the corner and the other approximately $2\frac{1}{4}$ " from the corner, or about one inch out of vertical registration. The witness Townsend testified (R. 303) that these upper and lower support portions of Faulkner were not vertically aligned.

The witness Townsend also testified (R. 304-307) that he did not find any of the vertically extending clearways in Faulkner as defined in claim 19 of the '535 patent. He said that he would have to bisect a wire which he painted red on the model Exhibit I in order to provide such a clearway.

With respect to the last clause of claim 19 of the '535 patent, namely, "the above named parts of a receptacle

permitting nesting and tiering of two like receptacles with their like parts in vertical registration one above the other," Townsend testified that this was not possible in Faulkner (R. 304, 305, 306). Townsend particularly called attention (R. 305) to two Faulkner receptacles in tiered position as shown on Fig. 6 of the patent (see Plate III attached hereto) and pointed to the V-shaped wires 14 which, in the tiered position, are at the right-hand end of the upper receptacle and at the left-hand end of the lower receptacle. Obviously in Faulkner like parts of two receptacles are not in vertical registration when in tiering position.

The difference in the means used to accomplish the nesting and tiering of receptacles is of real significance in the utility of the invention. Plaintiffs' witness Glezen testified (R. 43) that the difficulty with having two receptacles which must turn 180° between tiering and nesting is that the operator must always determine one of two directions when picking up a receptacle to set it down upon the other. He explained (R. 44) that it was difficult to determine which end was to be turned one direction or the other depending on whether you wanted stacking or nesting. As an example of this kind of container, Exhibit 2 was introduced (R. 43) showing two boxes which would nest in one position but had to be turned end for end in order to provide interfering points for tiering. This is exactly the kind of tiering and nesting structure shown in Faulkner, and the witness Townsend demonstrated (R. 303-307) that the reason the Faulkner device would not operate like the '535 patent or like Exhibit 9, accused, was because Faulkner did not have the upper and lower tiering support portions vertically above each other and did not have the clearways required by claim 19 so that a horizontal linear shifting of the upper receptacle relative

to the lower receptacle to clear the support points would open up clearways which would permit the upper receptacle to go down easily to nested position, with all parts of one receptacle above like parts of the lower receptacle and without the necessity of turning 180°.

Plaintiffs, therefore, believe the District Court erred in finding Faulkner as an anticipation of claims 19 and 20 of the '535 patent because there was not present in the Faulkner device the vertical relationship of the upper and lower tiering support portions of a given receptacle together with the clearways which would permit the tiering and nesting of two like receptacles with their like parts in vertical registration one above the other.

POINT 4.

THE '535 PATENT IS NOT ANTICIPATED BY PRIOR BLOM PATENT 2,684,766.

The Blom patent, sheet 1 of the drawings thereof, is reproduced and attached hereto as Plate IV. Defendants' witness Wilson stated (R. 212) that these cannot be stacked in a vertical stack. This is obvious by looking at Fig. 2 of Plate IV where the tongues 19 which are the lower tiering support portions of the upper receptacle are placed in the notches 17 which are the upper tiering support portions of the lower receptacle, thus providing a structure wherein the stack of receptacles leans toward the right as viewed in Plate IV so that after several were stacked and one got past the center of gravity, the whole stack would fall over as the witness Wilson testified (R. 217). This Blom patent was considered by the Patent Office (as printed at the end of the '535 patent) and the claims in suit were allowed over the Blom patent.

In an attempt to bolster up the inadequacy of the Blom patent as an anticipatory reference, defendants at-

tempted to introduce in evidence a certain Exhibit K which was not pleaded in defendants' answer and which was not made known to the plaintiffs thirty days before trial as required. Plaintiffs objected to the introduction of Exhibit K and any testimony relative thereto (R. 219-221).

The purpose of introducing the Exhibit K was to change the Blom patent by slanting the slots or clearways so as to place the upper support portion 17 vertically above the lower support portions 19 as taught in plaintiffs' '535 patent. Defendants' counsel read this portion of claim 19 to the witness Robbins when interrogating him using the language of claim 19 as follows (R. 242):

“Q. ‘* * * said upper support portions being vertically above said lower support portions * * *.’

A. The upper support portions being the recesses, 3, are directly above the lower support portions, being 4. This is the case in all four portions of the container.”

The above question and answer make it clear that the modification of Exhibit K was to apply the teaching of claim 19 of the '535 patent to the Blom patent.

The witness Robbins was asked (R. 240, 241) whether in his opinion the change from the Blom patent to Exhibit K, that is, slanting the clearways, would represent a patentable improvement. He answered “No”, that he would advise a client that it would be impossible to obtain a patent for such a deviation over the Blom structure. The witness Townsend testified (R. 309, 310) that it is easy to modify and reconstruct something once a patentee had told you how to do it. He stated that what is claimed to be obvious must itself at least be suggested by the prior art. He stated that he did not find any fair suggestion of this type of modification in the Blom patent. He further stated (R. 310) “quite, I think, to the contrary, the Blom patent

fundamentally relates to a series of trays that we would, I think, call letter or paper receptacles * * *. These are staggered types of receptacles that make access easy. And the Blom patent is one where, to look at the second sheet of drawings, is providing this type of thing. Blom clearly wanted to have his trays come off in a stepped angle because this is what he was really trying to accomplish. So that I would say that the Blom patent taught away from the modification rather than would lead toward it."

The Blom patent was modified to provide Exhibit K under the tutelage of defendants' patent counsel (R. 222). Mr. Jessup asked Mr. Wilson "and what were the instruction which I gave you?" The answer was: "I don't recall the exact instructions. However, you asked me to make two models of the Blom patent with the single exception that the space here is slanted rather than straight." Mr. Jessup: "The slots?" The answer: "The slots, yes."

Nevertheless, Exhibit K was not sufficient to anticipate claims 19 and 20 of the '535 patent. The record shows on pages 273 to 276 that the witness Robbins discovered that the Exhibit K receptacles would not nest in vertical line. This exchange is recorded (R. 275):

"The Court: Well, that is what I note now. Well, let me ask the question of the witness: Do you concede, then, that when these trays in the model K are nested that the stack of the nested receptacles would tend to lean away from the vertical according as you added numbers to the nested stack?

"The Witness: Yes, Your Honor. After you get high enough they will start off at an angle.

"The Court: And if you put enough of them they would tip over, wouldn't they?

"The Witness: If you got enough of them, I presume that is true, yes."

Following the above, the Court asked the witness Robbins whether this was different from plaintiffs' Exhibit 8 as to the manner of nesting and stacking and the witness Robbins said (R. 275, 276):

"Exhibit 8, yes. Never having seen more than just two of these, I couldn't say, but it appears that they would stack or nest and continue vertically up.

"The Court: And is the reason for that a difference in the way the clearway is constructed?

"The Witness: Your difference in your structure would be because the clearway in the Blom patent, it appears to me now, is a slotted * * * a slanted slot in the side, which is a solid side, and as you nest, these lugs which are the lower support point fit in here and will carry it upwardly as a result of that, whereas these are wires as opposed to the solid side."

Later in the trial before the District Court, acting on the above suggestion of Mr. Robbins, defendants' counsel made a further effort to reconstruct the Blom patent in order to anticipate the claims of the '535 patent in suit (R. 595, 596). Mr. Jessup, of defendants' counsel, then drew upon a blackboard a sketch which was later reproduced and appears as Exhibit C-9 for identification. This was introduced over plaintiffs' objection (R. 605) as being a speculation upon a speculation. The following exchange took place between Mr. Jessup and Mr. Robbins (R. 596):

"Q. Now, I'm going to make a change and ask you if you can visualize how this modification which is hypothetical, would nest. Suppose you were to change it * * * just supposing * * * to go over like this, carry the slot over like this; could you speculate how this basket would nest that I have now drawn here?

A. Well, I think that is a better design than the slanted line that you had in Exhibit K.

Q. How would that nest?

A. That would nest vertically.

Q. It would nest vertically and stack vertically, is that right?

A. Yes."

In view of the above discussion, plaintiffs state that it is obvious that the Blom patent 2,684,766 in no way anticipates claims 19 and 20 of the '535 patent in suit, because, first, it does not have upper support portions vertically above lower support portions, and, second, it does not have the clearways defined in claims 19 and 20 of the '535 patent. It was considered by the Patent Office during the prosecution of the '535 patent and claims 19 and 20 were allowed over that consideration. Furthermore, it took two attempts by defendants' counsel to change the Blom patent to agree with claims 19 and 20 of the '535 patent; the first change was to Exhibit K to place the upper and lower tiering support portions vertically in line with each other and the second change shown in Exhibit C-9 was to make the clearways conform to those taught in the '535 patent.

POINT 5.

EXHIBIT 9 INFRINGES CLAIMS 21 TO 28 OF THE '535 PATENT.

The District Court apparently did not consider these claims on their merits but held them not infringed because claim 20 was not infringed (21 to 28 being dependent upon claim 20). See Finding of Fact 21.

Plaintiffs' witness Townsend read these claims on the Exhibit 9 structure (R. 116 to 127). Appellants believe that if claim 20 is found valid and infringed, then claim 21 through 28 should also be found valid and infringed.

POINT 6.

**EXHIBIT O INFRINGES CLAIMS 20 TO 23 AND 25 OF THE
'535 PATENT.**

The question as to whether Exhibit O is properly in this lawsuit is argued elsewhere in this brief.

With respect to claim 20, the District Court applied the same erroneous tests with respect to "dimensions" and "clearways" as discussed hereinabove with reference to Exhibit 9. Plaintiffs rely on the arguments previously advanced in this respect.

Defendants' witness Robbins testified (R. 538) that Exhibit O would tier vertically in line, but in nesting they would be slightly out of line first in one direction, then in the other direction, and that every fourth receptacle in nested position would be vertically directly over the first one.

Mr. Townsend's testimony with respect to Exhibit O and the reading of claims 20 through 23 and 25 on that Exhibit is found in the record, pages 608 to 618.

Mr. Townsend read claim 20 on Exhibit O following much the same story as in the case of Exhibit 9 previously discussed. The chief exception related to the matter of Exhibit O nesting slightly out of line first in one direction and then the other which was a difference over Exhibit 9 which nested in direct vertical line one receptacle above the other. Mr. Townsend suggested that claim 20 could be read on Exhibit O if one gave a somewhat broader reading to the "clearway" clause of claim 20 (R. 612). Mr. Townsend also suggested that the doctrine of mechanical equivalents might be applied to Exhibit O (R. 612 to 614) inasmuch as the difference between Exhibit 9 and Exhibit O was a mere colorable change and with every fourth receptacle vertically above the bottom receptacle, a nested

stack of the Exhibit O receptacles would be substantially in vertical alignment.

In cross examination of Mr. Townsend with respect to the "dimensions" clause of claim 20, Mr. Townsend stated that there being no top bars across the ends of Exhibit O, the dimension lengthwise of Exhibit O at the upper portion thereof was infinite (R. 629).

For all of the above reasons, plaintiffs believe that claims 20 through 23 and 25 are infringed by Exhibit O and that the District Court erred in Findings of Fact 22 and 23 and Conclusions of Law 7, 8 and 9.

POINT 7.

EXHIBIT 9 INFRINGES CLAIM 7 OF REISSUE 24,731.

The question of whether reissue patent 24,731 is properly in this lawsuit is discussed elsewhere in this brief.

Defendants alleged non-infringement of this reissue patent and invalidity of the reissue. These subjects will be taken up in that order.

The first part of claim 7 reads as follows:

"A receptacle adapted for tiering and nesting with receptacles of like construction comprising a bottom load supporting part and upper edge parts, and side parts rigidly connected with said bottom part and with said upper edge parts, said bottom load supporting part and upper edge parts and side parts including upper tiering support members rigidly connected with said upper edge and side parts, said bottom load supporting part and upper edge parts and side parts including lower tiering support members rigidly connected with the side parts and said bottom part * * *."

This language clearly defines a rigid receptacle including a bottom, sides and upper edges with upper and lower tiering support members a part of the receptacle.

The defendants' position, unbelievably adopted by the lower Court in Finding No. 30, was that Exhibit 9 was so constructed with the sides and upper edges which included the upper support points, (Plate IIA) being a single piece of formed wire and the lower support points (Y) being formed by individual loops of wire, did not have upper support points rigidly connected with the bottom load supporting parts nor the lower support points rigidly connected with the upper edge. This in spite of the fact that all parts of Exhibit 9 were welded into a rigid, integrated receptacle.

The claim language describes a rigid receptacle with certain structural characteristics among which are upper and lower support points. Whether the manufacturing process makes use of endless formed wires welded together or cut wires welded together to form a rigid integrated receptacle having the required characteristics is of no importance. The issue is does the *receptacle* have the specified structural characteristics. Exhibit 9 obviously has upper and lower support points as integral parts.

Claim 7 also requires a clearway "downward from each of said upper support members and enterable by said corresponding lower support member of an upper like receptacle in like orientation only by manipulation after which said lower support members of said upper receptacle may pass downwardly in said clearways to a nested position in said lower receptacle."

All this language requires is that the clearway permit a nesting of the upper receptacle into the lower receptacle. It does not define the degree of the nesting nor require that the upper receptacle be nested to its full depth in the lower. The clearway which complies with the requirement is between the point where nesting terminates and the upper support members.

The position of the defendants, adopted by the lower Court in Finding 31, that the stop bar 10 of Exhibit 9 which limits the degree of nesting interrupts the clearway required by claim 7, is clearly erroneous.

It should be pointed out that claim 7 has no dimensional requirements for the receptacles.

They may be of any size, top, side and bottom so long as they have the other characteristics required by the claim. Exhibit 9 completely complies with these requirements and infringes claim 7 (R. 562 to 566).

In so finding, this Court would find error in Findings of Fact 30 and 31 and Conclusion of Law 13.

POINT 8.

CLAIM 7 OF REISSUE 24,731 IS VALID.

Finding of Invalidity of Claim 7 of Reissue 24,731 on the Ground No "Error" Alleged to Justify the Reissue.

This point was raised by the defendants' witness Robbins in his testimony respecting Exhibit C-7 which is the file wrapper and contents of the reissue patent 24,731. Mr. Robbins stated (R. 504) that in the oath on page 12 of Exhibit C-7 there were no averments respecting "error." The "oath" of the applicant Lockwood in the said reissue file states: "* * * that he believes that said Letters Patent No. 2,782,936 is wholly or partially inoperative or invalid for the reason that the patentee (the present applicant) claimed less than he had a right to claim in the patent." The statute authorizing the reissue of defective patents is found in Section 251 of Title 35, U. S. C. A., and is printed in full in Appendix I. In part, this statute states: "Whenever any patent is, through error without any deceptive intention, deemed wholly or partly inoperable or invalid, by reason of a defective specification or drawing, or by reason of the patentee claiming more or less than he had a

right to claim in the patent, the Commissioner shall * * * reissue the patent for the invention disclosed in the original patent * * *.” It will be noted that the oath in the re-issue patent application stated that the inventor believed that his patent was wholly or partially inoperative or invalid for the reason that the patentee claimed less than he had a right to claim.

This Court has held in *Moist Cold Refrigerator Company, Inc. v. Lou Johnson Company, Inc.*, 217 F. 2d 39:

“There has been some discussion of the effect, if any, of the omission of the words ‘inadvertence, accident, or mistake’ in Section 251 of the Patent Act of 1952. The reviser’s notes indicate that the omission of these words was not intended to change the substantive law, and it is clear that the test as to what type of error is required to warrant reissue remains the same as before.”

The witness Townsend testified (R. 554) that no specific oath was required by the statute, that the Patent Office decides whether the oath is sufficient, and that the Patent Office found this oath acceptable (R. 555).

“Where the Commissioner accepts a surrender of an original patent and grants a new patent, his decision in the premises, in a suit for infringement, is final and conclusive, and is not re-examinable in such a suit in the circuit court, unless it is apparent upon the face of the patent that he has exceeded his authority, that there is such a repugnancy between the old and the new patent that it must be held, as matter of legal construction, that the new patent is not for the same invention as that embraced and secured in the original patent.” *Seymour et al. v. Osborne et al.*, 76 U. S. 516, 20 L. Ed. 33. (This decision is quoted at greater length in Appendix II attached hereto.)

In *Topliff v. Topliff et al.*, 145 U. S. 156, 36 L. Ed. 658, the Supreme Court stated three tests for reissue. First, that it be for the same invention as the original patent; second, that due diligence must be exercised in discovering the mistake in the original patent; and, third, "that this Court will not review the decision of the Commissioner upon questions of inadvertence, accident, or mistake, but that the question whether the application was made within a reasonable time is, in most, if not in all such cases, a question of law for the court." (This decision is quoted at greater length in Appendix II attached hereto.)

The above quotation that the court would not review the decision of the Commissioner on the question of inadvertence, accident or mistake unless the matter is manifest from the record was again quoted by the court with approval in *Hobbs v. Beach*, 21 S. C. 409, 180 U. S. 383, 45 L. Ed. 586.

The above quotation was approved and followed as late as January 10, 1958 by the United States District Court of North Carolina in *Funchion v. Sommerset Knitting Co., Inc. et al.*, 158 F. Supp. 57 at page 60 where the court stated: "The reissue patent was granted in strict accordance with 35 U. S. C. A. Section 251 and Rules of Practice of the United States Patent Office, Rules 171 through 176, 35 U. S. C. A. Appendix. The determination of the Commissioner to grant the reissue on surrender of the original and his determination that the inoperativeness in the original specification arose from inadvertence, accident, or mistake is conclusive. *Mahn v. Harwood*, 112 U. S. 354, 360, 5 S. C. 174, 6 S. C. 451, 28 L. Ed. 665; *Topliff v. Topliff*, 145 U. S. 156, 171, 12 S. C. 825, 36 L. Ed. 658."

Finding of Invalidity of Claim 7 on the Ground That the Invention Claimed Therein Was Different From the Invention in the Original Patent.

Plaintiffs contend that the only difference between claim 7 of the reissue and the first six claims thereof is that claim 7 states in generic terms what is stated more specifically in the first six claims. The chief word giving this generic meaning of claim 7 is the word "manipulation" which occurs in the clause in claim 7 which states: "* * * there being a clearway provided between said bottom load supporting part and upper edge parts and side parts downwardly from each of said upper support members and enterable by said corresponding lower support member of an upper like receptacle in like orientation only by manipulation after which said lower support members of said upper receptacle may pass downwardly in said clearways to a nested position in said lower receptacle." The witness Townsend testified that this word "manipulation" covered both the tilting or rocking action for causing nesting in the '936 patent which was reissued, and also the horizontal shifting movement taught in the '535 patent in suit (R. 556, 578, 579). The District Court apparently adopted this point of view where he said in conclusion of Law 16: "A reissue that broadens the claims to cover a new, different combination not fully shown by the original patent to have been taught and intended is void. This is true even through the reissue claims a result that could be brought about by following the process of the original patent."

Plaintiffs have found it almost impossible to locate a case on all fours with the present situation, namely, where the reissue claim merely states in generic terms that which was originally claimed in the patent in specific terms.

A somewhat similar case is that quoted above, namely, *Funchion v. Sommerset Knitting Co., Inc., et al.*, 158 F. Supp. 57; where the original claims called for "a rotary table" on which certain forms were mounted to revolve with the table and in the reissue claims called for "means for supporting and conveying said * * * forms in a prescribed path of travel." There the court found (page 60): "There is no substantial evidence to sustain a finding that the reissue application was not filed timely; or that the patent was obtained deceptively, or that the disclosures of the original patent not adequately claimed, failed to embody the claims of the reissue or that the invention is not entitled to the protection of the reissue."

Plaintiffs are unable to understand how merely stating an invention in generic terms can possibly be for a "different invention" than the specific form which is encompassed in the genus.

Finding of Invalidity of Claim 7 on the Ground That the Subject Matter Claimed in the Reissue Patent Was in Public Use and on Sale in the United States More Than One Year Prior to the Filing of the Reissue Application.

Plaintiffs believe the District Court made Finding of Fact 29 because there was presented during argument the matter of *Crane Packing Company v. Spitfire Tool & Machine Co.*, 276 F. 2d 271. At page 274 of the reported decision, the Court of Appeals, Seventh Circuit, discussed the Patent Act of 1952 concluding with these remarks:

"We agree with the district court's conclusion that although a reissue application enlarging claims may be filed within two years from the original patent it is, nevertheless, subject to the conditions prescribed by Section 102(b) which are by reference incorporated

in Section 251. The district court did not err in holding Section 102(b) applicable and that claims 11 to 14, inclusive, were invalid because of public use and sale of Bullard's commercial device more than one year prior to the application for the reissue patent. And such holding is harmonious with the provision 35 U. S. C. A. Section 252 that a reissue patent 'to the extent that its claims are identical with the original patent, shall constitute a continuation thereof and have effect continuously from the date of the original patent.' Claims 11 to 14, inclusive, are not identical with any claim of the original patent."

The above decision of the Court of Appeals for the Seventh Circuit caused quite a furor in the patent profession and the same court clarified the situation later in *Union Asbestos and Rubber Company v. The Paltier Corporation*, 298 F. 2d 48 where at page 51 they made the following statement:

"There is nothing in the 1952 Patent Code to indicate that Congress intended thereby to change the long-established view as to reissue patents, that the defective patent, although amended and corrected, is still the same patent.

"It is difficult to conceive that Congress, in the last paragraph of section 251, would expressly provide that a broadened reissue patent may be applied for within two years of the grant of the original patent and by implication say that a narrowed reissue patent may be applied for over a longer period, if in the preceding paragraph it had referred to section 102(b) with the intent that all applications for reissue more than one year after publication of the original patent would be invalid. Had there been any intent to drastically alter the conditions of patentability with respect to reissue patents, Congress could and would have used appropriate language to say so."

More recently the Court of Appeals for the Sixth Circuit has examined this matter in the case of *Hartzell Industries, Inc. v. McCauley Industrial Corporation*, decided June 26, 1962 and reported at 304 F. 2d 481. At pages 483, 484 of this reported decision the court made the following statement:

“Essential to the granting of the reissued patent, therefore, was the Commissioner’s finding that Re-issue Patent No. 24,530 was for the invention disclosed in the original patent and, likewise, that the application therefor, including the new claims 8 and 9, did not introduce new matter. Initially we assume that he made such necessary finding. A reissue patent is given the same presumption of validity as that given to an original patent. *Hazeltine Research, Inc. v. Avco Mfg. Corp. et al*, 227 F. 2d 137, 146 (CA 7 1955); *England v. Deere & Co.*, 284 F. 2d 460 (CA 7, 1960).

“The last paragraph of Section 251, Title 35, U. S. C. A., provides that ‘No reissued patent shall be granted enlarging the scope of the claims of the original patent unless applied for within two years from the grant of the original patent.’ The patent laws contemplate that reissued patents may enlarge the scope of the claims of an original patent, including situations where in the patentee’s original application he claimed ‘less than he had a right to claim in the patent.’ The law contemplates that a patentee may use the rights given him by section 251 to more correctly describe an invention already patented. His new claims will not be held invalid against subsequent infringers merely because, for a year prior to his application for a reissue patent, he has been selling his invented device under the protection of his original patent.”

In the present state of the law on this point, as above set forth, it is believed that Finding of Fact 29 should be

disregarded in arriving at a decision as to the validity of claim 7 of the reissue patent.

35 U. S. C. A. 282 provides in part that:

“A patent shall be presumed valid. The burden of establishing invalidity of a patent shall rest on a party asserting it.”

The Defendants have failed to meet that burden of proof.

For all of the above reasons, plaintiffs believe that this Court should find that the District Court erred in Finding of Fact 27 through 32 and Conclusions of Law 10 through 13 and 16.

VI. RECAPITULATION AND CONCLUSION.

1. The patent field of identical receptacles without moving parts which both tier and nest vertically is not crowded. Only four such patents have been cited, two of which are Lockwood's and are herein involved, to-wit '535 and the reissue.

2. Only '535 provides identical receptacles without moving parts which tier and nest vertically with like parts vertically in line and without change in orientation of the receptacles in moving from a tiered to a nested position or vice versa by means of a lateral or horizontal shift. The commercial usefulness of this device has been proved by the evidence.

3. The novel characteristics of the '535 structures which give the above results are (a) upper support portions vertically above the lower support portions, (b) a structure dimensioned and with its parts so arranged that it will nest and stack with an identical receptacle with like parts vertically above one another, (c) clearways at support portions which will permit the upper receptacle to be

lifted and shifted laterally to permit the tiering support portions to be disengaged, and clear each other and then to move down into the lower receptacle with the lower support portion vertically underneath the upper support portion.

4. Exhibit 9 uses the identical structural characteristics to accomplish the identical result specified in the '535 despite its completely different physical appearance and infringes Claims 19 through 28 of the '535 patent.

5. There is no actual controversy between the parties as to the infringement of Claim 7 of the reissue patent by Exhibit 9. If there is such a controversy, (a) Exhibit 9 does infringe Claim 7 because it is a rigid receptacle having the upper and lower support points vertically in line with the attendant clearways required by said claim, and (b) the reissue patent is valid because it was issued in strict accordance with statutes and the rules of the Patent Office.

6. There is no actual controversy between the parties as to the infringement of Claims 20 to 23 and 25 of the '535 patent and if there is such a controversy, Exhibit O does infringe said claims under the doctrine of mechanical equivalents.

The Plaintiffs do respectfully urge that

(a) the judgment of the District Court be reversed and judgment entered in this Court for the Plaintiffs against the Defendants that Exhibit 9 does infringe Claims 19 through 28 of the '535 patent and enjoining said Defendants from further infringing said patent and remanding to the District Court for appropriate action the balance of the relief prayed for in plaintiffs Amended Complaint, and

(b) the Defendants' counter claim be dismissed, or

(c) if the Court determines that the counter claim

includes a justiciable issue or issues that this Court enter judgment for the Plaintiff and against the Defendant that Claim 7 of the reissue patent is valid and that Exhibit 9 infringes said claim and that Exhibit O infringes Claims 20 to 23 and 25 of the '535 patent.

Respectfully submitted,

BRONSON, BRONSON & MCKINNON,
JOHN F. WARD,

MEYER, BALDWIN, DORAN & EGAN,
GEORGE S. BALDWIN,

ROUDEBUSH, ADRION, BROWN, CORLETT & ULRICH,
MYRON W. ULRICH,

Attorneys for Appellant.

APPENDIX I.**U. S. C. A. Section 251.**

“Whenever any patent is, through error without any deceptive intention, deemed wholly or partly inoperative or invalid, by reason of a defective specification or drawing, or by reason of the patentee claiming more or less than he had a right to claim in the patent, the Commissioner shall, on the surrender of such patent and the payment of the fee required by law, reissue the patent for the invention disclosed in the original patent, and in accordance with a new and amended application, for the unexpired part of the term of the original patent. No new matter shall be introduced into the application for reissue.

“The Commissioner may issue several reissued patents for distinct and separate parts of the thing patented, upon demand of the applicant, and upon payment of the required fee for a reissue for each of such reissued patents.

“The provisions of this title relating to applications for patent shall be applicable to applications for reissue of a patent, except that application for reissue may be made and sworn to by the assignee of the entire interest if the application does not seek to enlarge the scope of the claims of the original patent.

“No reissued patent shall be granted enlarging the scope of the claims of the original patent unless applied for within two years from the grant of the original patent. July 19, 1952, c. 950, Section 1, 66 Stat. 808.”

APPENDIX II.

William H. Seymour et al. v. David M. Osborne et al., 78 U. S. 516, 20 L. Ed. 33.

“Authority to accept the surrender of the original patents in certain cases, and to grant new patents to the inventor, was conferred upon the commissioner by the Act of the 3rd of July, 1832, and in a case arising under that Act it was held by this court, more than thirty years ago, that where an act was to be done or a patent granted, upon proofs to be laid before a public officer, upon which he was to decide, the fact that such public officer had done the act or granted the patent was *prima facie* evidence that the proofs had been regularly made, and that they were satisfactory, even though the patent did not contain any recitals that the perquisites to the grant had been fulfilled; and such continued to be the rule until the question came up again for consideration under the existing Patent Act, when it was held by this court that the fact of the granting of the reissued patent closed all inquiry into the existence of inadvertence, accident or mistake, and left open only the question of fraud for the jury.”

“Where the commissioner accepts a surrender of an original patent and grants a new patent, his decision in the premises, in a suit for infringement, is final and conclusive, and is not re-examinable in such a suit in the circuit court, unless it is apparent upon the face of the patent that he has exceeded his authority, that there is such a repugnancy between the old and the new patent that it must be held, as matter of legal construction, that the new patent is not for the same invention as that embraced and secured in the original patent. *Battin v. Taggart*, 17 How., 83 (58 U. S., XV., 40); *O'Reilly v. Morse*, 15 How., 111, 112; *Sickles v. Evans*, 2 Cliff., 222; *Allen v. Blunt*, 3 Story, 744.”

“Prior to the decision of this court that a person sued as an infringer cannot abrogate a reissued or extended patent by showing that the commissioner had been induced to grant it by fraudulent representations, it had sometimes been supposed that every such new patent was open to that defense and that the question was one of fact dependent upon evidence, but since it has been determined that such a party cannot be heard to make such a defense to the charge of infringement, it has come to be regarded as the better opinion that all matters of fact involved in the hearing of an application to reissue a patent, and in granting it, are conclusively settled by the decision of the commissioner granting the application. Matters of construction arising upon the face of the instrument are still open, but all matters of fact connected with the surrender and reissue are closed in such a suit by the decision of the commissioner in granting the reissued patent. *Rubber Co. v. Goodyear*, 9 Wall., 796 (76 U. S. XIX, 568); *Stimpson v. R. R. Co.*, 4 How., 404; *R. R. Co. v. Stimpson*, 14 Pet., 458.” (pp. 38, 39 L. Ed.)

Isaac N. Topliff v. John A. Topliff et al., 145 U. S. 156; 36 L. Ed. 658.

“From this summary of the authorities it may be regarded as the settled rule of this court that the power to reissue may be exercised when the patent is inoperative by reason of the fact that the specification as originally drawn was defective or insufficient, or the claims were narrower than the actual invention of the patentee, provided that error has arisen from inadvertence or mistake, and the patentee is guilty of no fraud or deception; but that such reissues are subject to the following qualifications:

“First, That it shall be for the same invention as the

original patent, as such invention appears from the specification and claims of such original.

“Second, That due diligence must be exercised in discovering the mistake in the original patent, and that, if it be sought for the purpose of enlarging the claim, the lapse of two years will ordinarily, though not always, be treated as evidence of an abandonment of the new matter to the public to the same extent that a failure by the inventor to apply for a patent within two years from the public use or sale of his invention is regarded by the statute as conclusive evidence of an abandonment of the patent to the public.

“Third, That this court will not review the decision of the commissioner upon the question of inadvertence, accident, or mistake, unless the matter is manifest from the record; but that the question whether the application was made within a reasonable time is, in most, if not in all such cases, a question of law for the court.” (p. 664 L. Ed.)

April 5, 1960

W. H. LOCKWOOD

2,931,535

TIERABLE AND NESTABLE RECEPTACLE

Filed Feb. 6, 1957

17 Sheets-Sheet 16

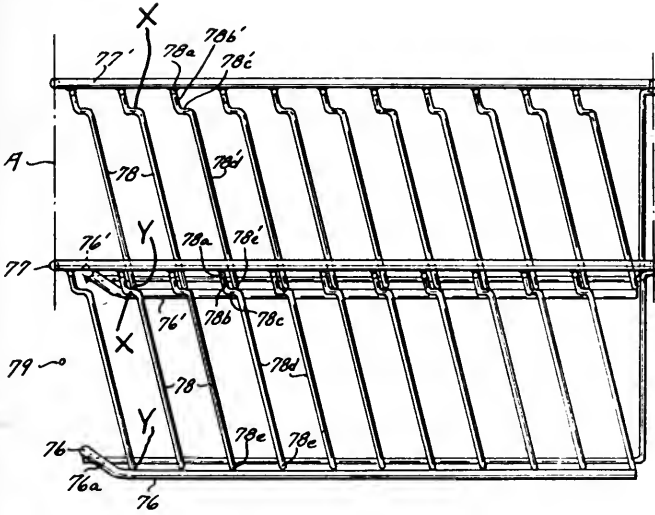

Fig. 37

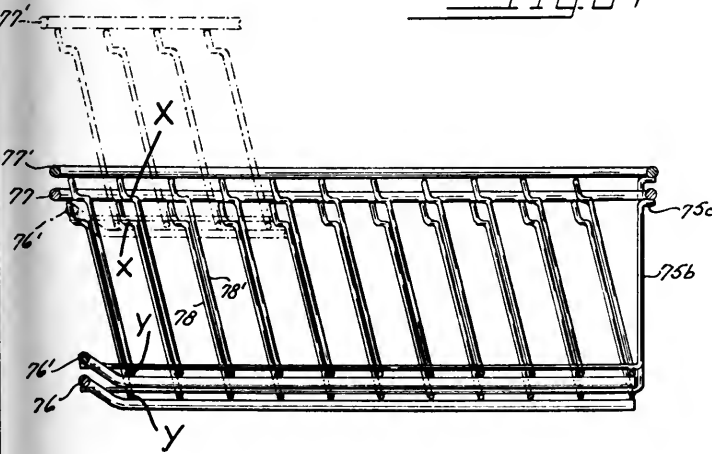
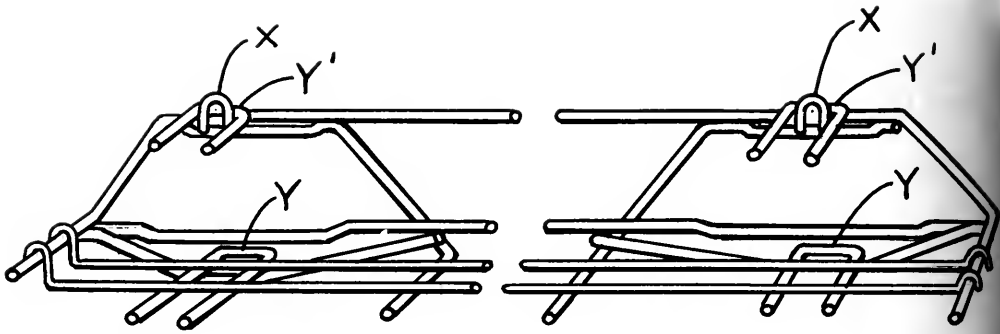

Fig. 38

PLATE I

INVENTOR.
WARREN H. LOCKWOOD
BY
Hyde, Meyer, Baldwin & Doran
ATTORNEYS



POSITION 1.

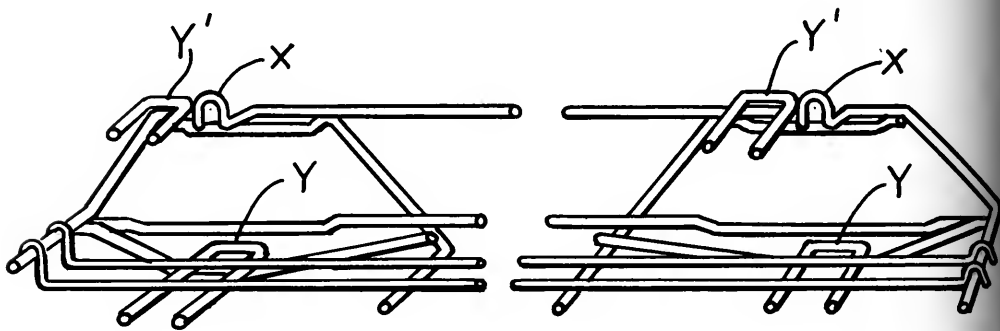

POSITION 2.

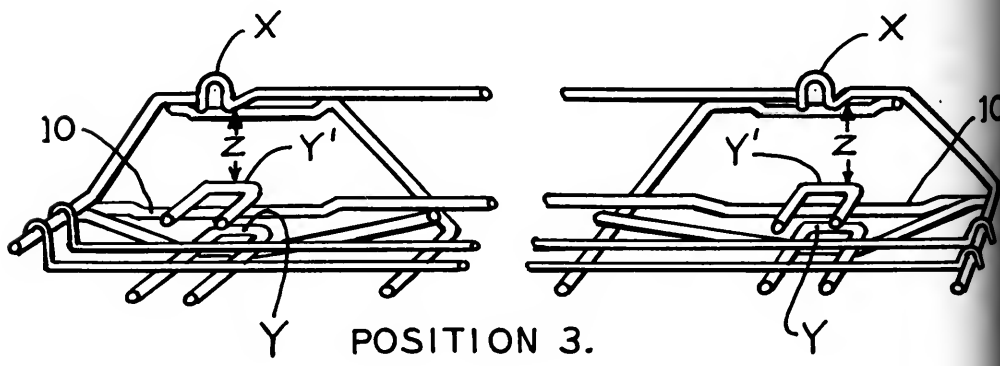

POSITION 3.

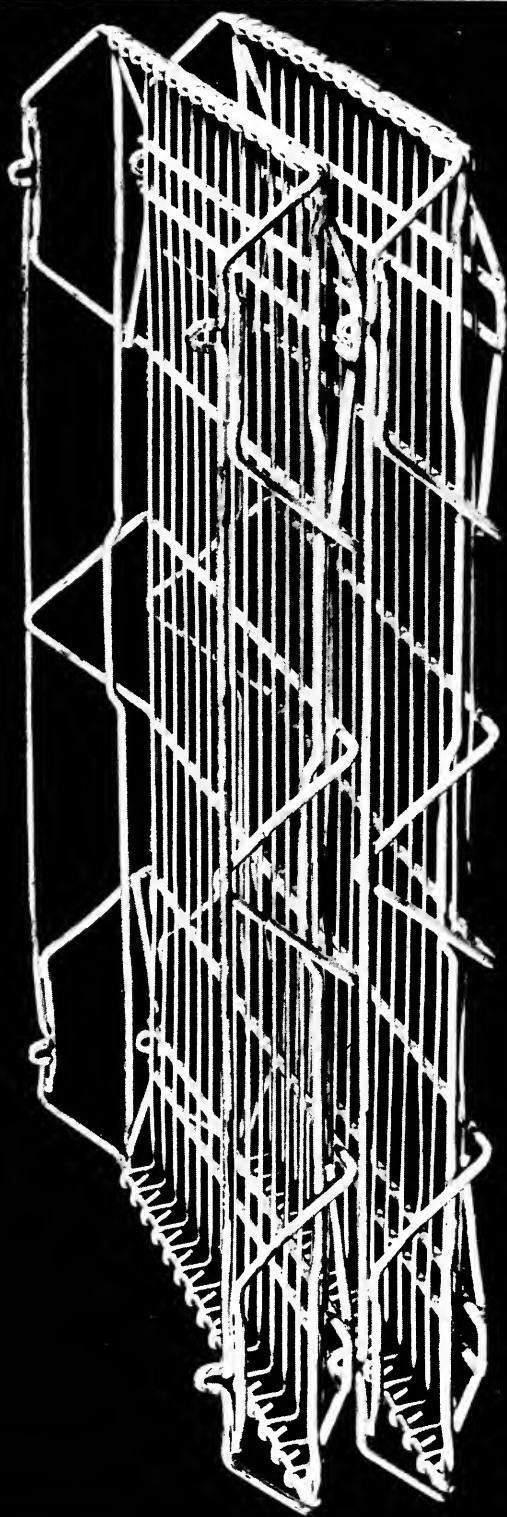

PLATE II A

Aug. 19, 1941.

A. T. FAULKNER
GRATE OR RECEPTACLE
Filed Aug. 25, 1939

2,252,964

2 Sheets—Sheet 2

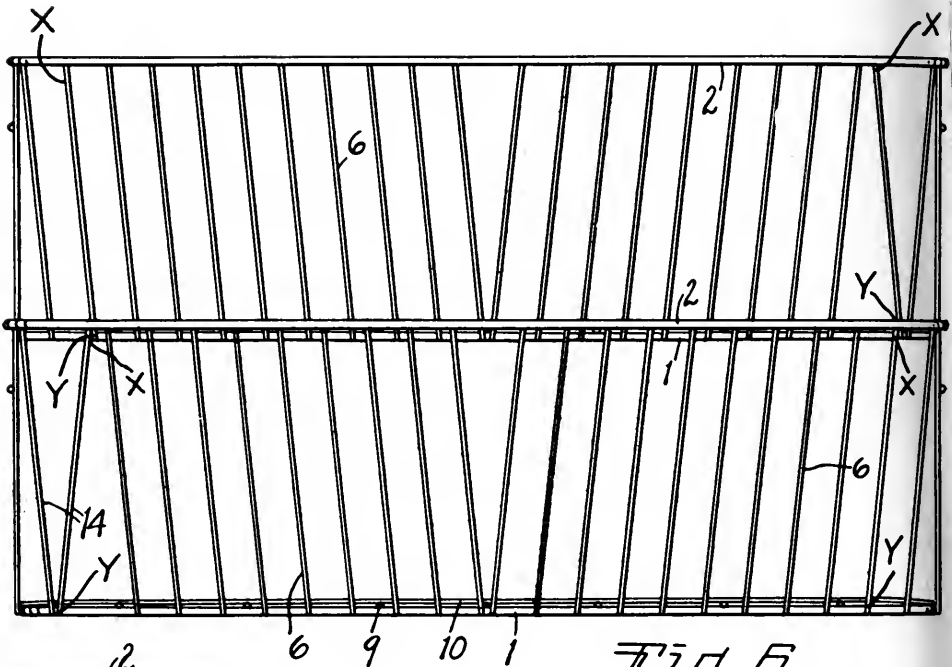

Fig. 6.

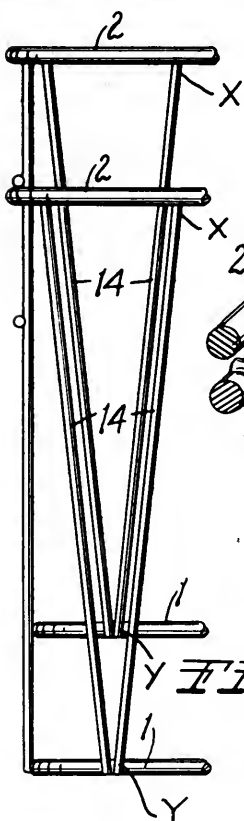

Fig. 7.

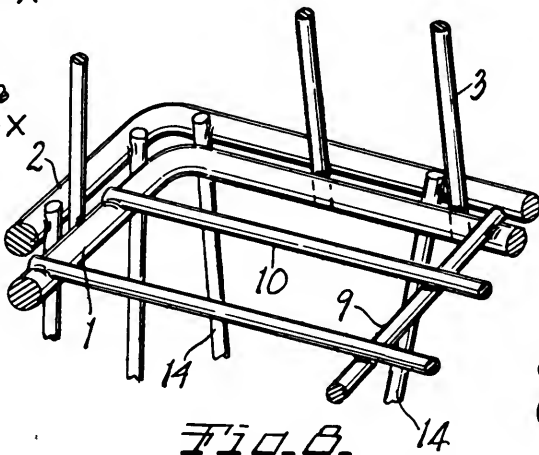

Fig. 8.

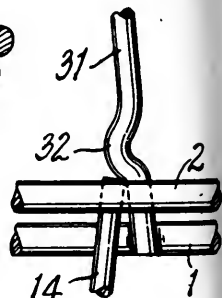

Fig. 9.

PLATE III

BY

INVENTOR
Arnold T. Faulkner
Earl & Shappell
ATTORNEYS

STACKABLE TRAYS AND HOLDER FOR SAME

Filed Dec. 29, 1950

2 Sheets-Sheet 1

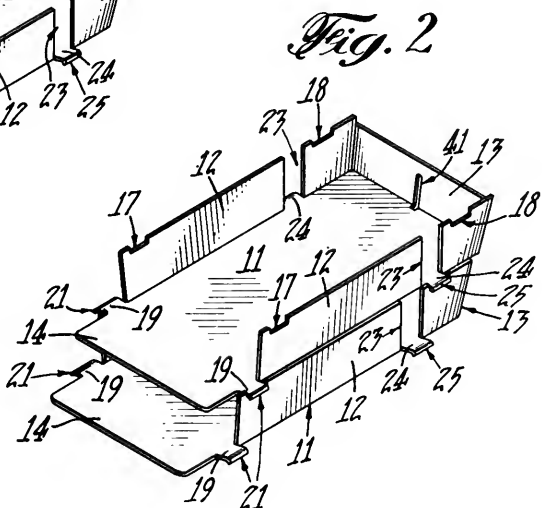
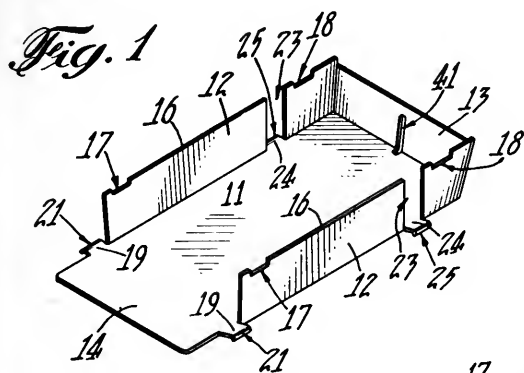

Fig. 4

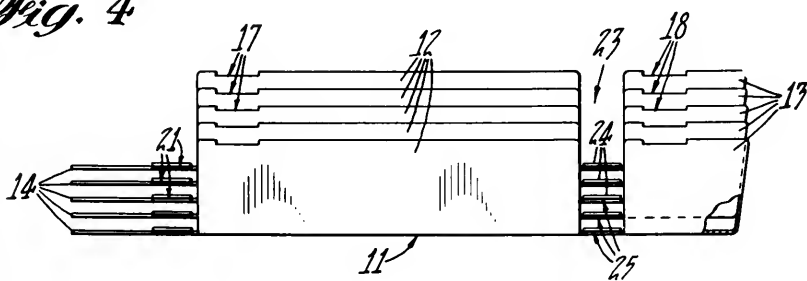

Fig. 5

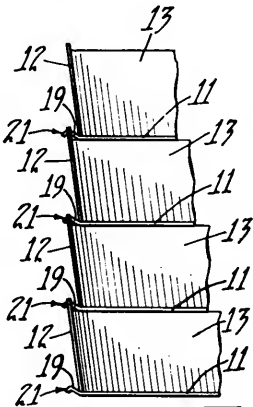
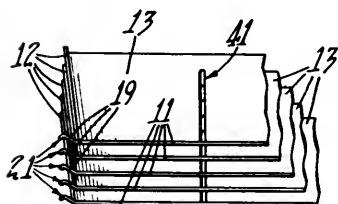

Fig. 3

INVENTOR.
 OTTO F. BLOM
 BY *Charles H. Erve*
Dean D. Thornburgh
 ATTORNEYS

April 5, 1960

W. H. LOCKWOOD

2,931,535

TIERABLE AND NESTABLE RECEPTACLE

Filed Feb. 6, 1957

17 Sheets-Sheet 12

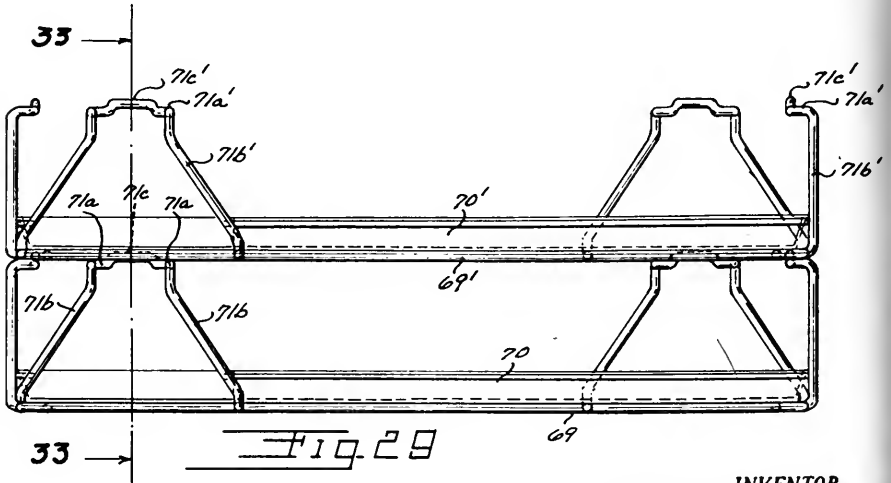
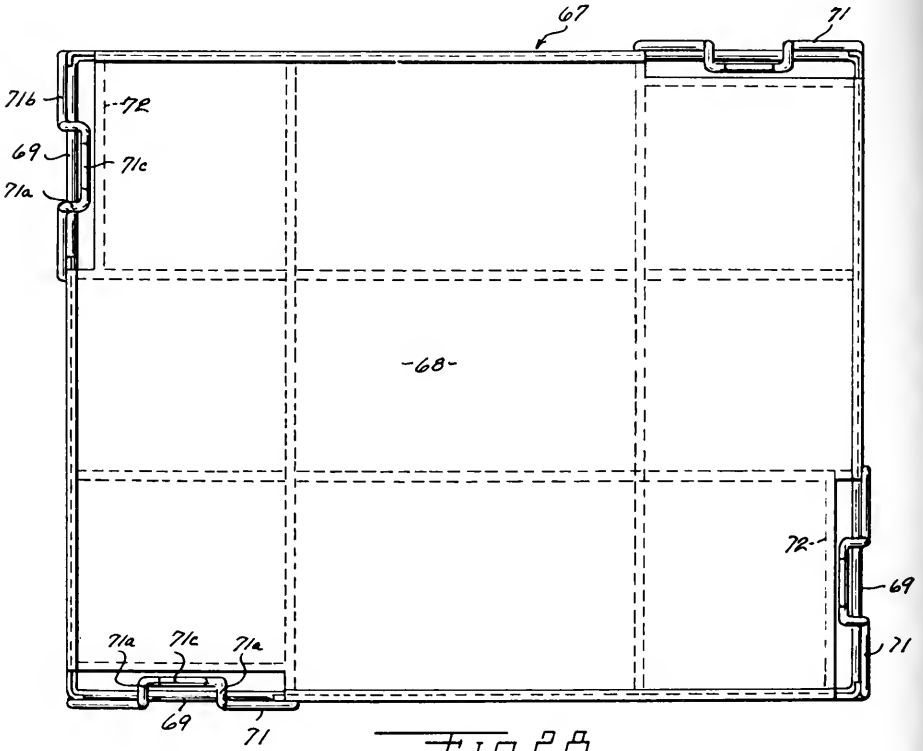

PLATE V

INVENTOR.
 WARREN H. LOCKWOOD
 BY
 Hyde, Meyer, Robinson & Doran
 ATTORNEYS

No. 18159

IN THE

United States Court of Appeals

FOR THE NINTH CIRCUIT

WARREN H. LOCKWOOD and MID-WEST METALLIC
PRODUCTS, INC.,

Appellants,

vs.

LANGENDORF UNITED BAKERIES, INC., and BANNER
METALS, INC.,

Appellees.

APPELLEES' (CROSS-APPELLANTS') BRIEF.

BOYKEN, MOHLER & FOSTER,
DIRKS B. FOSTER,

723 Crocker Building,
San Francisco 4, California,

KEITH D. BEECHER,

10889 Wilshire Boulevard, Suite 1206,
Los Angeles 24, California,

WARREN T. JESSUP,

First Federal Building, Suite 607,
1717 North Highland Avenue,
Hollywood 28, California,

Attorneys for Appellees (Cross-Appellants).

FILED

FIDLER, BEARDSLEY & BRADLEY,
ROY E. PETHERBRIDGE,

120 South LaSalle Street,
Chicago 3, Illinois,

Of Counsel.

EE - 7 1963

FRANK H. SCHMID, CLERK



TOPICAL INDEX

| | PAGE |
|---|------|
| Introductory statement | 1 |
| Jurisdiction of the action..... | 2 |
| Statement of case..... | 2 |
| Appellees' (cross-appellants') specifications of error..... | 4 |
| Summary of argument..... | 4 |
| Argument | 8 |
| Point 1. Concerning plaintiffs' contention that no justiciable issue exists as to the infringement of Patent '535 by Exhibit "O"; or as to the infringement of reissue patent by Exhibit "9"..... | 9 |
| Point 2. Concerning plaintiffs' contention that Exhibit "9" does in fact infringe claims 19 and 20 of patent '535..... | 17 |
| The significance of the "dimensions" limitation..... | 27 |
| The significance of the "clearway" limitation..... | 32 |
| Point 3. Concerning plaintiffs' contention that patent '535 is not anticipated by the prior Faulkner patent 2,252,964.. | 36 |
| Point 4. Concerning plaintiffs' contention that the patent '535 is not anticipated by the prior Blom patent 2,684,766 | 42 |
| Point 5. Concerning defendants' contention that claims 19 and 20 of patent '535 are invalid..... | 44 |
| Point 6. Concerning plaintiffs' contention that Exhibit "9" infringes claims 21-28 of patent '535..... | 45 |
| Point 7. Concerning plaintiffs' assertion that Exhibit "O" infringes claims 20-23, 25 of patent '535..... | 47 |
| Point 8. Concerning defendants' contention that the entire reissue patent '731 is invalid and not infringed..... | 48 |
| A. Invalid for lack of "error"..... | 48 |
| B. Invalid due to prior sale..... | 51 |
| C. No infringement | 52 |
| Conclusion | 58 |

TABLE OF AUTHORITIES CITED

| CASES | PAGE |
|---|--------|
| Becker v. Webcor, Inc., 289 F. 2d 357, 129 U. S. P. Q. 111.... | 25 |
| Borkland v. Pedersen, et al., 244 F. 2d 501, 113 U. S. P. Q. 401 | 40 |
| Briggs and Stratton Corp. v. Clinton Machine Co., Inc., 114 U. S. P. Q. 438, 247 F. 2d 397..... | 38 |
| Chicago Northwestern Railway v. Sales, 97 U. S. 554, 24 L. Ed. 1053..... | 46 |
| Crane Packing Co. v. Spitfire, 276 F. 2d 271..... | 52 |
| The Galion Iron Works & Mfg. Co. v. Beckwith Machinery Co., 25 Fed. Supp. 73, 38 U. S. P. Q. 90, aff'd 105 F. 2d 941, 42 U. S. P. Q. 209..... | 46 |
| Gearhardt v. Kinnaird, 162 Fed. Supp. 858..... | 49 |
| General Electric Co. v. Refrigeration Patents Corp., 68 U. S. P. Q. 324, 65 Fed. Supp. 75..... | 12, 13 |
| Glendenning v. Mack, 159 Fed. Supp. 665..... | 35, 53 |
| Grant v. Koppl, 99 F. 2d 106..... | 54 |
| Great Atlantic and Pacific Tea Co. v. Supermarket Equip- ment Corp., 340 U. S. 147, 87 U. S. P. Q. 303..... | 39 |
| Hall, et al. v. Wright, et al., 112 U. S. P. Q. 210, 240 F. 2d 787 | 9 |
| Hawley Products Co. v. U. S. Trunk Co., Inc., 259 F. 2d 69, 118 U. S. P. Q. 424..... | 44 |
| IDS Rubber Co. v. Essex Rubber Co., 272 U. S. 429..... | 26, 31 |
| Kalich v. Paterson Pacific Parchment Co., 137 F. 2d 649..... | 51 |
| Keymart v. Printing Arts Research, 201 F. 2d 644..... | 54 |
| McRoskeyl v. Braun Mattress Co., 107 F. 2d 143..... | 54 |
| Minneapolis-Honeywell Co. v. Midwestern Instruments, 188 Fed. Supp. 248, 127 U. S. P. Q. 149..... | 56 |

| | PAGE |
|---|--------|
| Moon v. Cabot Shops, Inc., 123 U. S. P. Q. 60, 270 F. 2d 539 | 9 |
| Riley v. Broadway-Hale, 217 F. 2d 530..... | 50 |
| Salem Engineering Co. v. National Supply Co., 76 U. S. P. Q. 255, 75 Fed. Supp. 993..... | 14 |
| Simmons Co. v. A. Brandwein Co., 256 F. 2d 440..... | 53 |
| Simmons Co. v. Sealy, Inc., 116 U. S. P. Q. 312, 157 Fed. Supp. 1 | 38 |
| Thompson v. Westinghouse Electric & Mfg. Co., 116 F. 2d 422, 48 U. S. P. Q. 49..... | 35, 53 |

STATUTES AND RULES

| | |
|---|----|
| United States Code Annotated, Title 28, Sec. 1291..... | 2 |
| United States Code Annotated, Title 28, Sec. 1338(a)..... | 2 |
| United States Code Annotated, Title 28, Sec. 2201..... | 2 |
| United States Code Annotated, Title 28, Sec. 2202..... | 2 |
| United States Code Annotated, Title 35, Sec. 102(b)..... | 52 |
| United States Code Annotated, Title 35, Sec. 112..... | 46 |
| United States Code Annotated, Title 35, Sec. 251..... | 48 |
| Federal Rules of Civil Procedure, Rule 52(a)..... | 8 |

TEXTBOOK

| | |
|---|----|
| Borchard, Declaratory Judgments (2d Ed.)..... | 12 |
|---|----|



No. 18159

IN THE

United States Court of Appeals

FOR THE NINTH CIRCUIT

WARREN H. LOCKWOOD and MID-WEST METALLIC
PRODUCTS, INC.,

Appellants,

vs.

LANGENDORF UNITED BAKERIES, INC., and BANNER
METALS, INC.,

Appellees.

APPELLEES' (CROSS-APPELLANTS') BRIEF.

Introductory Statement.

This brief includes, on an integrated basis, defendants' (appellees') counter-arguments with respect to the points raised in plaintiffs' (appellants') brief, and also arguments in support of the cross-appeal filed by the defendants (cross-appellants).

It is believed that all the issues of the case may be more easily presented by the integration of counter-arguments concerning the subject matter of plaintiffs' (appellants') Appeal with arguments supporting defendants' (appellees') Cross-Appeal.

Jurisdiction of the Action.

The present action was brought under the provisions of Title 28, U. S. C. A. Section 1338(a), in the United States District Court for the Northern District of California, Southern Division, for the alleged infringement of United States Letters Patent 2,931,535.

A Counterclaim for Declaratory Judgment as to the validity and infringement of the aforesaid United States Patent, and as to the validity and infringement of the United States Reissue Patent Re. 24,731, was filed pursuant to the United States Code, Title 28, Sections 2201, 2202.

The District Court found that an actual controversy existed between the parties, and that it had jurisdiction of this action [Par. 1 of its Conclusions of Law, Record Volume 1].

The Appeal and Cross-Appeal were taken from the final order of the District Court entered May 9, 1962 to this Court pursuant to the provisions of United States Code, Title 28, Section 1291.

Statement of Case.

Plaintiffs (appellants) have presented a summary of the facts of the present litigation. However, plaintiffs' summary is unduly lengthy and is clouded by extraneous, irrelevant facts. For that reason, defendants (appellees) deem it advisable to present a short restatement of the facts underlying the present action.

Plaintiffs, Warren H. Lockwood and Mid-West Metallic Products, Inc., originally brought the present action as an infringement suit against Langendorf United Bakeries, Inc., asserting infringement of United States Letters Patent 2,931,535 by Langendorf in its use of certain nestable-stackable receptacles.

Lockwood asserted himself to be the inventor and owner of the aforesaid United States Patent [R. 85, 89], and Mid-West Metallic Products asserted itself to be the exclusive licensee under the patent [R. 50, Ex. 7].

Banner Metals, Inc., as manufacturer of the accused receptacles, was permitted to intervene as a co-defendant [Record Volume 1, Order filed January 23, 1961].

Plaintiffs then amended their Complaint and charged *both* defendants Langendorf and Banner with infringement of said Letters Patent 2,931,535 [Record Volume 1, Amended Complaint filed January 30, 1961].

Defendants answered [Record Volume 1, Answer filed April 4, 1961] denying infringement of Patent 2,931,535 and averring invalidity of the patent. At the same time, defendants Counterclaimed for a Declaratory Judgment of non-infringement and invalidity of Patent 2,931,535; and also of non-infringement and invalidity of a second Lockwood Patent, namely, Reissue Patent Re. 24,731; the Reissue Patent being closely related in subject matter to the aforesaid Patent 2,931,535.

During the trial, two different receptacles were produced by defendants and were litigated. These receptacles were identified as Exhibits 9 and 0 respectively.

The District Court held in favor of defendants on the basis of numerous Findings of Fact and Conclusions of Law. The District Court ruled that there was no infringement by defendants of Patent 2,931,535, nor of the Reissue Patent Re. 24,731; and that claim 7 of Re. 24,731 is invalid.

Appellees' (Cross-Appellants') Specifications of Error.

1. The Court erred in limiting its finding of invalidity of the Reissue Patent Re. 24,731 to claim 7 only; it should have found that the entire Reissue Patent Re. 24,731 is invalid.

2. The Court erred in limiting its ruling on Patent 2,931,535 to non-infringement; it should further have found that claims 19 and 20 of Patent 2,931,535 are invalid.

Summary of Argument.

Point 1: Concerning plaintiffs' (appellants') contention that no justiciable issue exists as to whether or not Exhibit 9 infringes the Reissue Patent Re. 24,731; and as to whether or not Exhibit O infringes United States Patent 2,931,535; so as to support defendants' (appellees') Counterclaim for Declaratory Judgment.

The purpose of defendants' Counterclaim was to obtain a full judicial determination as to whether or not defendants and their customers may manufacture, sell and use the Exhibit 9 and Exhibit O receptacles without threat of litigation by the plaintiffs.

Plaintiffs brought the original suit on their Patent 2,931,535 and asserted infringement of that patent by the Exhibit 9 receptacles. However, plaintiffs asserted that the Exhibit 9 receptacles *also* infringe the Reissue Patent Re. 24,731 [Record Volume 1, Answers to Defendants' Interrogatories 3 and 4, filed July 7, 1961 in reply to Defendants' Interrogatories filed April 25, 1961]. Moreover, plaintiffs also threatened defendant Banner's customer Safeway Stores [Ex. C2] and asserted infringement of their Patent Re. 24,731 by the Exhibit 9 receptacles.

Plaintiffs also asserted that the Exhibit O receptacles infringe the original patent in suit, Patent 2,931,535, and also infringe the Reissue Patent Re. 24,731 [Record Volume 1, Replies to Defendants' Interrogatories 1, 2, 5, 6, filed July 7, 1961].

As will be discussed in detail hereinafter, it is believed that a justiciable controversy clearly exists, and that defendants are entitled to a declaratory relief.

Point 2: Concerning plaintiffs' (appellants') contention that the Exhibit 9 receptacles infringe claims 19 and 20 of the '535 patent, despite numerous findings by the District Court to the contrary.

The District Court's holding of non-infringement is supported by numerous Findings and Conclusions. The Findings are based upon a studied comparison of the evidence presented on both sides of the issue, and there

is no basis for any contention that the Findings are clearly erroneous.

Point 3: Concerning plaintiffs' (appellants') contention that the '535 Lockwood patent is not anticipated by the prior Faulkner Patent 2,252,964.

The District Court did not expressly rule on this issue, merely asserting: "In any event, the most that can be said is that any 'invention' in '535 must reside in the specific structure." [Record Volume 1, Memorandum Opinion p. 16]. It is appellees' contention in their cross-appeal, however, that the District Court *should* have ruled on the invalidity of claims 19 and 20 of the '535 patent, and this point will be taken up subsequently.

Point 4: Concerning plaintiffs' (appellants') contention that the Lockwood '535 patent is not anticipated by the prior Blom Patent 2,684,766.

As noted, the District Court did not rule on the issue of validity of the Lockwood '535 patent, and that issue will be treated subsequently herein.

Point 5: It is defendants' (appellees') contention that, as a matter of law, the District Court should have ruled that claims 19 and 20 of the '535 patent are invalid over the prior Faulkner and Blom patents.

Point 6: Concerning plaintiffs' (appellants') contention that Exhibit 9 infringes claims 21-28 of Lockwood '535.

As stated in Finding of Fact 21, claims 21-28 are dependent claims; and a holding of non-infringement of claim 20 makes the infringement of claims 21-28 impossible.

Point 7: Concerning Plaintiffs' (appellants') assertion that Exhibit O infringes claims 20-23 of the '535 patent.

All the reasons presented for non-infringement by Exhibit 9 apply equally to Exhibit O.

Point 8: Defendants' (appellees') contend that not only is claim 7 of the Reissue Patent Re. 24,731 invalid, as held by the District Court; but that the *entire* Reissue Patent is invalid, and not infringed.

A. Defendants' contention of invalidity is based on the premise that the statutory requirements of "error" were not met in securing the Reissue Patent Re. 24,731.

B. A sale of containers covered by the Reissue Patent Re. 24,731, made more than one year prior to the application therefor, invalidates the Reissue Patent.

C. There is no infringement of the Reissue Patent Re. 24,731.

ARGUMENT.

The decision of the District Court was based on numerous questions of fact on which a large volume of evidence was received, and on which thirty-four Findings of Fact were rendered.

Plaintiffs list nine (9) specifications of error in their Appeal Brief, and these specifications are based, for the most part, on Findings of Fact by the Trial Court.

It would appear from their Appeal Brief that plaintiffs are attempting to reargue the merits of the case and to quarrel with the Findings by the District Court. Indeed, plaintiffs have seen fit to support their contentions by the introduction in their Appeal Brief of new evidence in the form of Plates II and IIA. Such evidence was not offered at the trial, and it is improper to attempt to introduce it at this late date.

Although defendants welcome the opportunity again to argue the issues of this case on its merits, it should be pointed out that it is not the function of an Appeal Court to re-examine the entire matter as a *de novo* proceeding.

Attention is also invited to Rule 52(a) of the Federal Rules of Civil Procedure:

“. . . Findings of fact shall not be set aside unless clearly erroneous and due regard shall be given for the opportunity of the trial court to judge the credibility of the witnesses . . .”.

As pointed out in the case of *Moon v. Cabot Shops, Inc.*, Court of Appeals, Ninth Circuit, 123 U. S. P. Q. 60, 64, 270 F. 2d 539:

“The factual finding of the trial court that the accused devices are not equivalent to the patent claims, as so construed, is not to be disturbed unless clearly erroneous.”

See also the case of *Hall v. Wright*, Court of Appeals, Ninth Circuit, 112 U. S. P. Q. 210, 212, 240 F. 2d 787:

“A finding of fact that the subject matter of a patent lacks invention over the state of the prior art should, therefore, not be disturbed unless the finding is clearly erroneous.”

There is believed to be no basis for any contention that the Findings of the District Court in the present action are “clearly erroneous”.

Point 1.

Plaintiffs (appellants) contend that no justiciable issue exists as to whether or not Exhibit 9 infringes the Reissue Patent Re. 24,731; and as to whether or not Exhibit O infringes United States Patent 2,931,535, so as to support defendants' counterclaim for Declaratory Judgment.

The question as to whether or not a justiciable issue exists was dealt with at length and in detail by the District Court. Indeed, the District Court ruled on that particular issue in a separate Opinion [R. 466-476], which was read from the bench on November 14, 1961, and which will be referred to in some detail subsequently herein.

As mentioned in appellants' brief (p. 6), on October 18, 1960, Lockwood and Mid-West entered into an agreement with the defendant Banner [Ex. 5] for the disposition of an action then pending in the United States District Court in Cleveland, Ohio. By this agreement [Ex. 5] plaintiffs waived all their rights to assert claims 6 and 7 of the Reissue Patent Re. 24,731 against the Exhibit 9 receptacles made prior to October 18, 1960. However, it should be noted and stressed, that the Exhibit 5 agreement does not inhibit plaintiffs from asserting infringement of the Reissue Patent Re. 24,731 against Exhibit 9 receptacles made *after* October 18, 1960.

Mr. Ryan testified [R. 390-398] that the Exhibit 9 receptacles have been manufactured by the defendant Banner and sold to the defendant Langendorf, and also to Safeway Stores. Mr. Ryan also testified [R. 392] that Safeway Stores had been threatened by Mid-West; and letters evidencing such threats have been introduced in evidence [Ex. C2].

There is no question, therefore, but that customers of the defendant Banner Metals, Inc. have been charged by plaintiffs with infringement of the Reissue Patent Re. 24,731 in their use of the Exhibit 9 receptacles.

The fact that no receptacles were made or sold by the defendant Banner Metals, Inc. after October 18, 1960 is certainly not conclusive as to the existence of a justiciable issue. This stalemate was the natural result of the pending and threatened litigation, and of the previous threats made against customers.

Plaintiffs' waiver in the agreement [Ex. 5] does not protect, from charges of infringement of Re. 24,731,

any subsequent purchases made by the defendant Langendorf of Exhibit 9 receptacles manufactured by the defendant Banner after October 18, 1960. Plaintiffs have formally stated that they believe the receptacles Exhibit 9 infringe the Reissue Patent [Answers to Defendants' Interrogatories 3 and 4, Record, Volume 1, filed July 7, 1961].

Therefore, unless the issue of infringement of the Exhibit 9 receptacles with respect to the Reissue Patent Re. 24,731 is decided now; defendants will not be in a position to manufacture, sell or use the Exhibit 9 receptacles without fear or threat of litigation from the plaintiffs.

The above-mentioned unhappy condition with respect to the Reissue Patent Re. 24,731 would exist, regardless of the outcome of the suit on Patent 2,931,535 originally in suit. It was therefore of paramount importance to the defendants that the entire situation with respect to *both* '535 patent and the Reissue patent '731 be cleared up. For reasons to be discussed in detail herein, there is believed clearly to exist a justiciable controversy between the parties as to *both* these patents. This continued threat to Banner's right to manufacture the Exhibit 9 receptacles, and to Langendorf's right to use them, obviously creates a justiciable controversy.

The other Banner receptacle, Exhibit O, although not yet actually sold, has been shown to prospective customers [R. 405-408], and Banner has constructed machinery specifically for the purpose of making receptacles such as Exhibit O [R. 420-423].

Therefore, the situation with respect to the Exhibit 9 receptacles is that these receptacles have been manu-

factured and sold to the defendant Langendorf, and to others, by the defendant Banner Metals, Inc.; and the Exhibit 9 receptacles have been used by the defendant Langendorf. Also, other customers of the defendant Banner to whom the receptacles Exhibit 9 have been sold, have been charged with infringement and threatened by plaintiffs in their use of the receptacles Exhibit 9.

The agreement Exhibit 5 refers and grants immunity, *only* to Exhibit 9 receptacles made before October 18, 1960. However, in view of the threats by plaintiffs and charges of infringement of the Reissue Patent Re. 24,731, defendants seek a judicial declaration as to the lack of infringement of the Exhibit 9 receptacles so that these receptacles can be made and sold in the future without fear of litigation.

With respect to the receptacles Exhibit O, these have been manufactured by the defendant Banner, and defendant has expended money in production machinery which would be used in the manufacture of such receptacles. Plaintiffs have formally stated that they believe the receptacles Exhibit O infringe both the Patents 2,931,535 and Reissue Re. 24,731 [Record, Volume 1, Answers to Defendants' Interrogatories 1, 2, 5, 6, filed July 7, 1961].

Although, from the existing factual situation, it is clear that a justiciable controversy exists, plaintiffs have seen fit to cite the standard text, *i.e.*, Borchard's "Declaratory Judgments" (2nd Edition), at page 25 of their Brief, to support their contrary contention. However, they have refrained from completing the quoted section.

Borchard continues, as cited in *General Electric Co. v. Refrigeration Patents Corp.*, District Court, Western

District, New York, 68 U. S. P. Q. 324, 326, 65 F. Supp. 75:

“In the (declaratory judgment) cases thus far decided, there have usually been two elements present, actual manufacture, use or sale by the petitioners, and charges of infringement by the patentee . . . but actual manufacture, use or sale ought not to be essential. It ought to suffice that the party charged is about to infringe or take some action which is prejudicial to the interests of the patentee, and that he is then charged or put on notice that his action is attacked as an infringement, present or prospective.”

It must be appreciated, therefore, that the facts of the present case fall squarely within the philosophy of the very Borchard test cited by plaintiffs, and that under Borchard’s philosophy, declaratory judgment *would clearly* lie in the present situation.

The Court in the above-cited *General Electric* case goes on to say:

“What this author (Borchard) has said as respects the right of a patentee is applicable equally respecting the rights of a prospective manufacturer as against a patentee claiming infringement. An actual controversy cannot exist till the patentee has made the claim that his patent was being infringed, but the notice need not be a formal one . . .”.

In the present case, with respect to Exhibit O, we have a “prospective manufacturer”. However, here we go *beyond* the requirements of the *General Electric* case that the notice of infringement “need not be a formal one”; and in the present case we have a formal notice

of infringement by the plaintiffs in their Answers to Interrogatories 1 and 2, 5 and 6 filed July 7, 1961 [Record, Volume 1]. Therefore, no amount of protestation by plaintiffs can gainsay the clear fact that they do believe that Exhibit O infringes the patents in suit, and they have so asserted formally and in writing. That the reply to the interrogatories was by court order, does not alter the ultimate fact situation created. The interrogatories *do* establish that plaintiffs consider the patents infringed by the Exhibit O receptacles.

A situation similar in all respects to the present situation arose in *Salem Engineering Co. v. National Supply Co.*, District Court, Western District, Pennsylvania, February 5, 1948, 76 U. S. P. Q. 255, 260; 75 F. Supp. 993:

“The fact which may be reasonably anticipated of harrasing the purchasers of the manufacturer by claims for damages would be to diminish the manufacturers opportunities for sale. No one wishes to buy anything if with it he must buy a law suit If a manufacturer fears that he will be charged to infringe, he can always inquire of the patentee, and if the answer is unsatisfactory, he can bring an action for declaratory judgment. The time has now passed when a patentee may sit by and refuse to show his hand.”

The clear purpose for defendants' Counterclaim was to obtain a judicial determination as to whether or not defendants and their customers may manufacture, sell and use the Exhibit 9 and Exhibit O receptacles without charges of infringement and threat of subsequent litigation by the plaintiffs.

A determination of non-infringement, based solely on Patent 2,931,535, would be of no aid or help to the defendants or their customers.

This is because defendants' customers had actually been told [Ex. C-2] that the same receptacles Exhibit 9 infringe the related Reissue Patent Re. 24,731. The fact that an agreement [Ex. 5] exists concerning only those receptacles Exhibit 9 made *before* a particular date; does not clarify defendants' right to make, use and sell the receptacles Exhibit 9 after the date specified in the agreement Exhibit 5.

With respect to Exhibit O receptacles, the fact that these receptacles have been manufactured and displayed, and the fact that plaintiffs have formally indicated that such receptacles are considered by them to be an infringement of their Patent 2,931,535, is sufficient to permit a declaratory judgment action.

As noted previously, the issue as to justiciable controversy was ruled on by the District Court in favor of the defendants, and the District Court's opinion may be found in the transcript [R. 466-476]. For convenience, pertinent portions of the District Court's Opinion are set forth herein:

"The further question remains whether the counter claim seeking declaratory judgment presents justiciable issues with respect (1) whether receptacle Exhibit 9, the subject of the original complaint, infringes plaintiff's Reissue Patent '731; and (2) whether receptacle Exhibit O infringes plaintiffs' patent '535 . . .

"As to receptacle Exhibit 9, . . . the evidence shows that on October 18, 1960 plaintiffs and

Banner entered into an agreement under which the plaintiffs agreed not to assert their claim of infringement under Reissue Patent '731 with respect to such receptacles (Exhibit 9) as had been made and sold prior to October 18, 1960; . . .

“Plaintiffs, however, entered into no such waiver with respect to sales of Exhibit 9 taking place after October 18, 1960.

“The evidence shows that Banner has invested \$15,-000.00 at least in machinery for making receptacles Exhibit 9, and about \$15,000.00 for dies.

“It appears further that twenty or thirty of receptacles Exhibit O have been made as production models, and have been demonstrated to customers, but that none have been actually sold and that no orders have yet been received.

“In view of the competition of the parties . . . and in view of the history of the relationship of the parties with respect to past disputes . . . ; in view of the fact that receptacle O has actually been produced and demonstrated to potential customers; and in view of the fact that plaintiffs admittedly asserted that its sale and use would infringe patent '535, the Court considers that the issue presented with respect to receptacle O is such as to present more than a request for an advisory opinion of the Court, and that the controversy with respect to receptacle Exhibit O is sufficiently present and real and substantial as to present a justiciable issue, and that a declaratory judgment thereon would be within the scope of the Declaratory Judgment statute and in accordance with its purpose and in the interests of justice.

“The Court also holds that with respect to receptacle 9 and its possible infringement of patent '535 (Reissue '731), and in that case also the issue presented is more than a request for an advisory opinion and is sufficiently present and real and substantial as to present a justiciable issue, and that declaratory judgment relief is appropriate and suitable in the interests of judgment.”

It is believed clear, therefore, that the existence of a justiciable controversy is amply supported by the facts of this case, and that an action under the Declaratory Judgment Act is proper. It is also pointed out that all the issues were fully adjudicated at the trial, evidence on both sides was presented. Plaintiffs put on a full case through their expert, asserting infringement of one or both patents by both receptacles Exhibits 9 and O, followed by a vigorous argument to the same effect. Yet now plaintiffs would have this Court believe that defendants have no reason to apprehend a threat of infringement action by plaintiffs. Such a position is absurdly untenable. The District Court ruled after a full trial that defendants are free to make Exhibits 9 and O. Defendants should be permitted to market their receptacles under the aegis of that ruling.

Point 2.

Plaintiffs (appellants) contend that the Exhibit 9 receptacle infringes claims 19 and 20 of the '535 patent.

Such a contention creates the burden of showing that Findings of Fact 10, 12, 15, 16, 17, 18, 19, 20, and 23 [Record, Volume 1 Opinion of District Court] are “clearly erroneous”.

Finding of Fact 10 states that the receptacles of the '535 patent are characterized by the fact that, when tiered, the bottom of the upper receptacle lies inside the top of the lower receptacle.

Finding of Fact 12 states that the Banner receptacle Exhibit 9 is an independent invention, conceived by Wilson without any knowledge of the Lockwood receptacles disclosed in patent '535.

Finding of Fact 15 points out that claim 19 of the '535 patent contains the limitation "the dimensions of the lower part of one tray lying inside the dimensions of the upper part of a like tray"; and that this limitation was inserted in the claim during the prosecution of the patent to overcome a rejection on an earlier patent.

Finding of Fact 16 specifies that, contrary to the requirements of claim 19, the receptacles Exhibit 9 are constructed so that when tiered, the lower part of an upper receptacle does *not* lie inside the dimensions of the upper part of a lower receptacle.

Finding of Fact 17 states that the Exhibit 8 exemplar of the receptacles of patent '535 is construed such that the lower part of an upper receptacle *does* and *must* lie inside the dimensions of the upper part of a lower like receptacle.

Finding of Fact 19 states that claim 19 of the '535 patent contains a further limitation there, there be a "generally vertically extending clearway from directly above each lower point of support of an upper receptacle extending upwardly to the upper points of support of a lower receptacle when two like receptacles are nested". This Finding also states that Exhibit 9 does *not* contain the structural features of the generally vertically extending clearway required by claim 19.

Finding of Fact 20 also states that claim 20 of the '535 patent is similarly limited by the relative dimensions between upper and lower receptacles in the requirement that "the dimensions of the upper and lower parts of said receptacles permitting the lower part of an upper receptacle to enter vertically downward into the upper part of a lower like receptacle."

Finding of Fact 23 states that the limitations in claims 19 and 20 of plaintiffs' patent '535 concerning dimensions lying inside, and concerning clearways, are *not* found either *literally*, *substantially*, or *equivalently* in the defendants' Exhibits 9 or O.

As noted above, a contention that, despite the ruling of the District Court, Exhibits 9 and O *do* infringe claims 19 and 20 of the '535 patent, would require a holding by the Appeal Court that the Findings of Fact outlined above are not based on substantial evidence and are "clearly erroneous".

However, these Findings of Fact are based on a detailed examination of the evidence by the District Court, as represented by the exhibits introduced by both parties, including defendants' Exhibits 9 and O; and on a studied and detailed comparison by the District Court of the claims 19 and 20 of the '535 patent with the Exhibits 9 and O; these Findings of Fact are also based upon arguments and briefs submitted by counsel for both parties; and upon the testimony of witnesses, including experts for both sides. It is believed evident that the Findings are clearly based on substantial evidence and are clearly proper.

The Court's attention is particularly invited to the cross-examination of the plaintiff's expert witness

Townsend on this issue [R. 128-141]; and to the testimony of defendants' expert witness Robbins on the same issue [R. 266-268].

In its Opinion, at pages 7-13 [Record, Volume 1], the District Court commented upon the fact that conflicting expert testimony had been introduced by the plaintiffs and the defendants with respect to the infringement by Exhibit 9 and claims 19 and 20 of the Lockwood patent '535. The District Court stated at page 8, line 8 *et seq.* of the Opinion:

“This conflict arose out of different constructions placed by the respective experts upon claim 19 of Lockwood '535 in two principal respects of which the most important is the limitation in claim 19 concerning dimensions of the lower part of an upper tray lying inside the dimensions of the upper part of a like lower tray.”

The Court also stated at page 10, line 13 *et seq.* of the Opinion that:

“A conflict in the testimony of the experts also arose out of different constructions placed by them on another limitation of claim 19 concerning a generally vertically extending clearway from directly above each lower point of support of an upper receptacle extending upwardly to the upper points of support of an upper receptacle when two like trays are nested.”

After weighing the evidence, and after examining the Exhibit 9 receptacles and claims 19 and 20 of the '535 patent, and after a consideration of the briefs and arguments of Counsel; the District Court concluded that the claimed dimensions and clearways did not appear in

the accused article Exhibit 9, and held non-infringement of the patent.

Attention is invited to the following testimony of defendants' expert witness Robbins on the issue [R. 266-268] as constituting a portion of the evidence on which the aforementioned Findings of Fact were based, and which led to the adjudication by the District Court of no infringement:

"Q. Mr. Robbins again referring to claim 19 of Lockwood '535 I will read you a clause from that claim, starting at column 16, line 5. The clause reads as follows: 'there being a generally vertically extending clearway from directly above each lower point of support of an upper receptacle extending upwardly to the upper point of support of a lower receptacle when two like receptacles are nested'. Can you find such a defined clearway in the Banner receptacle Exhibit 9? A. Since this clause, claim 19, calls for the receptacles to be in the nesting position, I will place them in that position. The clause also calls for the vertically extending clearways from directly above each lower point of support of an upper receptacle, which would be in this position. Extending upwardly to the upper point of support of the lower receptacle. Now, this being your lower point of support of the upper receptacle, the clearway is called for extending to the upper point of support of the lower receptacle, and you will find this bar (marked 10) blocking the clearway. So I would say that I cannot find such a clearway in Exhibit 9, and this is true at each of the four corners of Exhibit 9.

Q. I will also read you a second clause, a further clause, from claim 19 of Lockwood '535, starting at column 16, line 9. This clause reads as follows: 'the dimensions of the lower part of one tray lying inside the dimensions of the upper part of a like tray . . .'. A. If we define the dimensions of the lower part of one tray as including this area, (indicating Exhibit 9) including the upper . . . or lower, rather, support members of the lower portion of this tray; and if we define the upper dimensions of the upper part of a like tray as including these loops, you find that the dimensions of the lower part of one tray cannot fit inside the dimensions of the upper part of a lower tray, and in fact they are spaced slightly above as shown here.

Q. I will direct your attention to claim 20 of Lockwood '535, and I will read you a clause of claim 20 starting at column 16, line 43: 'the dimensions of the upper and lower parts of said receptacle permitting the lower part of an upper receptacle to enter vertically downward into the upper part of a lower like receptacle and permitting a shifting movement of said upper receptacle relative to said lower receptacle . . .'. A. You find again, as I just testified a moment ago with respect to the clause in claim 19, that the dimensions of the lower part of an upper receptacle (again referring to Exhibit 9) interfere with the dimensions of the upper part of a lower receptacle, so that the lower part of the upper does not fall within the upper part of the lower container."

As noted above, on the basis of this studied comparison in Robbins' testimony between claim 19 of the '535 patent and Exhibit 9; and upon the basis of an examination of the various Exhibits, and of the Patents in suit; and on the testimony of both expert witnesses, the foregoing Findings of Fact were made; and the Court concluded that Exhibit 9 did not infringe the Lockwood '535 patent. It is believed clear that the aforesaid Findings of Fact are based on substantial evidence, and that it cannot be validly stated that they are "clearly erroneous".

The District Court also pointed out at page 11 of its Memorandum Opinion:

"Even if a claim can be read in terms upon an accused article, infringement does not necessarily follow unless it can be found as an ultimate fact that the article uses the inventor's idea as embodied in the inventor's design and drawings and that there is sameness or equivalence of function and means. See: *Trenton Industries v. Peterson*, 165 F. Supp. 523, 529 (S.D. California 1958); *Grant v. Koppl*, 99 F2d 106 (Ninth Circuit 1938); *McRoskey v. Braun Mattress Co.*, 107 F2d 143, 147 (Ninth Circuit 1939).

"The mere fact that the accused article performs the same function and achieves the same result as the patented article does not necessarily establish infringement unless it can be found that this is accomplished in substantially the same way and where, as in this case, the art is fairly crowded and the main elements of the patent are found or indicated in the prior art, this issue should be determined narrowly rather than liberally. If in fact, not

merely colorably, the accused article departs from the teaching of the patent in the means by which it achieves the result there is no infringement. *Johnson & Johnson v. Carolina Lee Knitting Co.*, 258 F2d 593, 597 (Fourth Circuit 1958). . . .

In a combination patent, such as involved in this case, every element of a particular claim is presumably essential and, therefore, every element of the claim, or its functional equivalent, must ordinarily be found in the accused article. See *Q-Tips, Inc. v. Johnson & Johnson*, 207 F2d 509 (Third Circuit 1953).

“Where, as in this case, no embodiments of the patent asserted by plaintiff have ever been produced for commercial use, that circumstances is one calling for a narrow rather than a liberal construction of its claim. See: *Thompson v. Westinghouse Electric*, 116 F2d 422, 425 (Second Circuit 1940); *Glendenning v. Mack*, 159 F. Supp. 665, 668-669 (D. Minn. 1958).

“Also, as in this case, an applicant has been required to narrow his claim in order to distinguish it, any contention of the applicant that such claim is not essential or that it is infringed by an equivalent in the accused article, should be considered with care and subjected to a narrow rather than a liberal construction. See *IDS Rubber Co. v. Essex Rubber Co.*, 272 US 429, 433 (1926).”

In the light of the evidence received during the trial, and in the light of the legal principles set forth, the District Court concluded [Finding of Fact 23] that the limitations of claims 19 and 20 of the '535 patent concerning dimensions lying inside and concerning clearway

are not found either literally, substantially or equivalent in the receptacles Exhibit 9.

On the basis of the aforesaid evidence and legal principles, the above-mentioned Findings of Fact 10, 12, 15, 16, 17, 19 and 20 were formulated; such Findings *are* based on substantial evidence and cannot validly be considered to be “clearly erroneous”.

Attention is invited to the case of *Becker v. Webcor, Inc.*, Court of Appeals, Seventh Circuit, 289 F. 2d 357, 129 U. S. P. Q. 111, 113 (1961):

“We are faced with a situation on appeal here in which we must give great weight to the findings made by a trial Judge who saw and heard the experts testify. He had personal opportunity to understand the explanation of the tests, the charge and results produced and the effect to be accorded the extended examination of the witnesses before him. After the conclusion of the testimony the trial court had the further benefit of briefs by the parties. The court, after indicating a finding favorable to Webcor on all issues, directed Webcor’s counsel to prepare and submit proposed Findings and Conclusions leading to the judgment for defendants. This was done. The trial court adopted 38 Findings of Fact and 18 Conclusions of Law in the form as submitted. We have carefully examined all of them . . .”.

The Appeal Court in the *Webcor* case affirmed the judgment of the District Court. It is believed that the present situation is analogous to the *Webcor* case.

Instead of attempting to show that the Findings of the District Court are clearly erroneous, plaintiffs, in

their brief, have attempted to open up the entire argument concerning the “dimensions” and “clearways” causes of claims 19 and 20 of the '535 patent.

Plaintiffs' attempt to reopen these issues extends even to the reference to exhibits not in evidence, in the form of Plates II and IIA of their brief, which plates were not offered during the trial.

In their argument concerning the “dimensions” clause, plaintiffs, at page 32 *et seq.* of their brief, raises certain specious references to “structural definitions” and to the meaning of “dimensions”.

As noted, the “dimensions” clause was inserted in claims 19 and 20 of the '535 patent specifically to distinguish the claims from an earlier patent [Finding of Fact 15], and in the face of the refusal by the Patent Office to allow the claims unless such a distinguishing limitation were inserted in them.

It is of no moment that certain illustrations of the '535 patent, as noted in plaintiffs' brief, may show trays which do not extend into one another when stacked. The *claimed* invention of '535, as set forth in claims 19 and 20, requires such a relationship.

As pointed out by the District Court in its Opinion (*supra*) any limitation inserted by an application into a claim in order to distinguish it from the prior art, cannot later be contended to be inessential, citing *IDS Rubber Co. v. Essex Rubber Co.*, 272 U. S. 429, 433.

Not only do plaintiffs attempt on appeal to reopen the arguments concerning the “dimensions clause” limitations of claims 19 and 20, but they also seek to reopen arguments on the “clearways clause” of these claims

(Pltf. Br. p. 36 *et seq.*). Again, in an attempt to bolster their arguments, the plaintiffs rely on the newly submitted evidence, namely Plate II, of their brief.

It should be pointed out, as noted above, that after weighing evidence presented on both sides, the District Court found that the required clearways of claims 19 and 20 do not exist in the receptacles Exhibit 9, because of the interrupting bar 10.

The following is a detailed reply to the plaintiffs' contentions concerning the "dimensions" limitations and the "clearways" limitations.

The Significance of the "Dimensions" Limitation.

The true significance of the "dimensions" limitation in claims 19 and 20 of the '535 patent, as it was intended by the applicant and understood by the Patent Office Examiner during the prosecution of the patent, can best be appreciated by studying the history of these claims as they progressed through the Patent Office. This history is to be found in the file wrapper of patent 2,931,535 [Ex. 10].

Claim 19 in the patent application as filed [pp. 32 and 33 of Ex. 10] originally read as follows:

"19. A receptacle, adapted for tiering and nesting with other like receptacles, having a bottom means and upwardly extending means rigidly connected with said bottom means at spaced points about the periphery of said bottom means, there being a plurality of upper tiering support portions rigid with said upwardly extending means and adjacent the upper end thereof, a plurality of lower tiering support portions rigid with one of said means and adjacent said bottom means, said upper support

portions being vertically above said lower support portions, said support portions being distributed about the periphery of said bottom means and positioned to hold an upper receptacle firmly and evenly when said lower support portions of an upper receptacle engage upon said upper support portions of a lower like receptacle, there being a vertically extending clearway from directly above each lower point of support extending upwardly to the uppermost position of the upper points of support of a lower receptacle when two like receptacles are nested, there being a vertically extending clearway from a point to one side of and adjacent each upper point of support extending downwardly near to the lowermost portion of the lower points of support of an upper receptacle when two like receptacles are nested, said upwardly extending means being so constructed and arranged as to nest with like parts of a like receptacle, said second named vertically extending clearways all being positioned at that side of the associated upper points of support so that a shifting of an upper receptacle relative to a lower receptacle from a tiering position, in a direction so that all parts of the shifted receptacle move generally in horizontal planes only, will place all of said lower points of support of an upper receptacle vertically over said second named vertically extending clearways of a lower like receptacle, after which the upper receptacle may be moved downwardly in a second like receptacle to nested position, the above named parts of a receptacle permitting nesting and tiering of two like receptacles with their like parts in vertical registration one above the other.”

In his first Action on the application [p. 52 of Ex. 10], the Patent Office Examiner rejected the claims, including claim 19, "as unpatentable over the patent to Lockwood ('936)". (The '936 patent is the early Lockwood patent which subsequently was reissued as Reissue 24,731 also involved in the present law suit). In this rejection the Examiner stated:

"In Lockwood, attention is called to Figures 9 to 11 on which these claims read in all material respects. Insofar as the structure positively set forth in the claim is concerned, it is a matter of indifference whether the device is rotated slightly on a horizontal or a vertical axis."

In response, the applicant tacitly acquiesced in this determination by the Examiner, and inserted the following limitation in claim 19:

"the dimensions of the lower part of one tray lying inside the dimensions of the upper part of a like tray". [P. 54 of Ex. 10].

In commenting on this added limitation, the applicant noted [P. 55 of Ex. 10]:

"These claims now clearly distinguish structurally over the Lockwood patent by reciting that the bottom of one tray has dimensions which fit inside the upper portion of a like tray. This is obviously impossible in Lockwood's Figures 9 to 11 cited by the Examiner."

This obvious impossibility noted by Lockwood's attorney is due entirely to the lugs 48 of an upper tray (Figure 10 of '936) which form the lower tiering support portions, and which engage upper tiering support

portions 53 of a lower tray, when two like trays are tiered. *However, this identical relationship is also found when the Banner Exhibit 9 trays are tiered.* Therefore, if the added “dimensions” limitation of claim 19 is to distinguish over the prior art trays of Figure 10 of Lockwood '936, this limitation must equally distinguish the claim from the Banner trays Exhibit 9, so that infringement by the trays Exhibit 9 of claim 19 is manifestly impossible.

At the trial, plaintiffs took the position that in defendants' Exhibits 9 and O, once the upper tray has been manipulated to institute the nesting action, the dimensions of the lower part of an upper tray do, of course, lie inside the dimensions of the upper part of a lower tray, because this is obviously a requirement for the nesting. If such a meaning is ascribed to the added limiting clause in claim 19, however, the necessary distinction over the trays shown in Figures 9 to 11 of the prior art '936 patent would be entirely lost. Therefore, this could not possibly have been the meaning intended by either the Examiner or the applicant during the prosecution of the application.

The clear meaning of this limiting “dimensions” clause must have been to distinguish the partial pre-nesting capabilities illustrated in Figures 37 and 41 of the '535 patent, and of the tiered trays exemplified three dimensionally in Appellants' Exhibit 8, from the trays shown in Figure 10 of the '936 prior art patent. This clause distinguishes with identical cogency over defendants' Exhibits 9 and O.

The law is well settled that an applicant may not insert a limitation under the aegis of one connotation to

secure an allowance over a reference patent ('936), and then urge a different meaning in order to expand his claim so as to capture an alleged infringer [*e.g.* Exs. 9 and O]. Note *I.D.S. v. Essex*, 272 U. S. 429.

Here the plaintiff is in effect attempting to ignore the "dimensions" limitation, which was deliberately added [P. 54 of Ex. 10], by so construing claim 19 to cover defendants' Exhibit 9 that it must of necessity cover the trays of Figure 10 of the '936 prior art reference patent, the very prior art over which it was supposed to distinguish.

The record thus shows beyond question the significance and meaning which the Examiner and the applicant ascribed to this "dimensions" limitation during the prosecution of claim 19. Then, when claim 20 was added, the inference is inescapable that the same significance for the "dimensions" limitation was understood by both the Examiner and the applicant. In addition, further language in claim 20 offered emphasis to this understanding. Claim 20 contains this limitation:

"the dimensions of the upper and lower parts of said receptacle permitting the lower part of an upper receptacle to enter vertically downward into the upper part of a lower receptacle".

This latter clause points up the distinction between the partial nesting feature of the tiered trays of Figure 37 ('535) on the one hand, and the tiered trays of Figure 10 of the Lockwood patent '936, and of defendants' Exhibits 9 and O, on the other hand.

Claim 20 still further specifies:

“. . . and permitting a shifting movement of an upper receptacle relative to said lower receptacle involving moving said bottom portion of said upper receptacle and generally in a horizontal plane”.

Logical meaning can be ascribed to the above limitation only when the receptacles are first considered in the tiered position shown in Figure 37 of the '535 patent. It is only in this attitude that the “dimensions” limitation distinguishes over the prior art Lockwood patent '936. Not only had the Examiner been previously conditioned to this meaning of the “dimensions” language by virtue of the prosecution of claim 19, but there is the added explanation in claim 20 that this dimensional relationship is one which permits:

“. . . a shifting movement of the upper receptacle relative to the lower receptacle involving moving said bottom portion of said upper receptacle generally in a horizontal plane”.

This shifting movement obviously refers to the preparations for nesting, wherein the receptacles are taken from the tiered position shown in Figure 7 of the '535 patent (where the dimensions are as recited in claim 20) to a position where the upper receptacle is ready to be dropped into nested position in the lower receptacle.

The Significance of the “Clearway” Limitation.

In addition to the “dimensions” limitation, discussed above, claim 19 of '535 also contains a specific limitation concerning the extent of the “clearway”, a feature not present in either of the Banner receptacles Exhibits 9 or 0. The “clearway” limitation is also present in claim 7 of the Reissue Patent Re. 24,731.

Referring first to claim 7 of the Reissue Patent, this limitation reads as follows:

“there being a clearway provided between said bottom load supporting part and upper edge parts and side parts downwardly from each of said upper support members”.

This “clearway” is substantially the same in all of the examples illustrated in the reissue patent. For example, in Figure 1 of the reissue patent, the “upper support member” is the bar 20 shown in Figure 1, while the “bottom load supporting part” is obviously that portion of the tray 19 immediately below the bar 20. It is clear in Figure 1 of the Reissue Patent Re. 24,731, as well as all the other figures of the reissue patent, that this space between these two parts is completely free. And it must be free to achieve the close nesting taught in the drawings and specification of the patent.

This structural “clearway” is not found in the Banner receptacles, and specifically Exhibit 9, which is the one charged to infringe claim 7 of the reissue patent. Assuming *arguendo* that there is a “clearway” in the Banner basket, in the sense intended by claim 7 of the Reissue Patent Re. 24,731, there can be no question that this “clearway” does *not* meet the structural description set forth in the claim, which requires that the clearway extend between the bottom load supporting part and the upper support member. In Banner, the “clearway” instead of extending to the lower support member, is frustrated by a special nesting member 10 which prevents the close nesting taught by the reissue patent.

In claim 19 of '535 this "clearway" is defined as follows:

“. . . there being a generally vertically extending clearway from directly above each lower point of support of an upper receptacle extending upwardly to the upper point of support of a lower receptacle when two like receptacles are nested”.

The "clearway" in the Banner receptacle, Exhibit 9 (assuming again that there is a "clearway" in the meaning intended in claim 19 of '535) does not extend "from directly above each lower point of support", but on the contrary does not start until well above the lower point of support, by virtue of the special nesting stop 10 referred to above.

The "clearway" recited in claim 19 of patent '535 is viewed when one receptacle is nested in another, and the limits of the "clearway" are defined in terms of two nested receptacles, rather than a single receptacle, as was the case in claim 7 of the reissue patent. Again, the special nesting stop 10 of the Banner receptacles, Exhibit 9, serves to terminate and frustrate the "clearway" whether the "clearway" be defined in terms of two nesting baskets, as in claim 19 of Lockwood patent '535, or in terms of a single basket (as in claim 7 of the Lockwood Reissue Patent Re. 24,731).

In addition, as evidenced by plaintiffs' responses [filed July 28, 1961, Record Volume 1] to defendants' interrogatories 28-35 [filed July 10, 1961, Record Volume 1][Ex. M] the invention of Lockwood patent '535

as represented by the numerous embodiments disclosed in the patent, has never enjoyed any commercial sale, and that none of the embodiments have been produced commercially, and that most of the embodiments have never been built at all. Therefore, the patent '535 is, under the law, a "paper patent" so that its claims must be given a most narrow and limited construction. This is illustrated by the following decisions: *Thompson v. Westinghouse Electric & Mfg. Co.*, Court of Appeals, Second Circuit, 116 F. 2d 422, 425; 48 U. S. P. Q. 49:

"As no commercial use has been made of the patent in suit it should, though good for what it clearly does cover, not be expanded beyond that . . . and the claim must be read not to discover merely whether it verbally covers what defendants have done, but whether it does when construed in the light of what was actually disclosed."

Glendenning v. Mack, District Court of Minnesota, 159 F. Supp. 665, 668; 116 U. S. P. Q. 249:

"Non-use of a patent does not relate only to novelty, but to the question of infringement. The underlying basis for the application of a paper patent theory as applied to infringement is that an inventor is not entitled to restrain progress of his art by failing to use his invention. His invention is given narrow range of equivalents when he fails to utilize his invention so that progress in the art may continue freely despite unused patent. Courts are reluctant to give a patent any broader scope than is clearly required to be given when the patent alleged to have been infringed has never been used."

Point 3.

That appellants contend that the '535 Patent is not anticipated by the prior Faulkner Patent 2,252,964.

If this assertion by the appellants is to be sustained, the following Findings must be found to be erroneous:

“24. The idea of tierable, nestable receptacles or baskets having no moving parts, which may be changed from tiered to nested position by a lateral shift into nesting clearways was not new with Lockwood, nor was the idea of receptacles which both tier and nest in vertical alignment.

25. The prior art Faulkner patent 2,252,964 teaches tierable, nestable receptacles without moving parts in which movement from tiered to nested position is effected by a rotational manipulation, without tilting, of the upper receptacle above the lower receptacle to align it with clearways that make nesting possible. In Faulkner, tiering as well as nesting produces exact vertical stacking or alignment. Faulkner was not cited by the Patent Office Examiner during the prosecution of the '535 patent.”

Appellants' primary objection to the use of the Faulkner structure as a prior art reference appears to reside in the fact that the upper receptacle of the Faulkner patent must be rotated 180° to move it from a tiering position to a nesting position.

The Faulkner patent is, however, a nestable-stackable receptacle which does not require movable parts. The upper receptacle is nested into a lower receptacle by a rotation of 180°. The prior art Faulkner receptacles are capable of tiering and nesting in a vertical stack

which has no tendency to digress from “exact vertical registration of one receptacle to the other”. The features of the Faulkner receptacles are expressly stated in the Finding of Fact 25. Appellants have not attempted to assert any error in this Finding.

The manner in which the prior art Faulkner receptacles are nested into one another is, admittedly, different from the non-rotational shift of the latter two embodiments of the Lockwood '535 patent. Moreover, it may be granted that the amount of rotational shift required to nest the Faulkner receptacle is greater than that required to nest certain embodiments of Lockwood patent '535.

However, Lockwood's attorney himself stated in describing the rotational shift receptacles of Lockwood patent '535 in the file wrapper [Ex. 10] at page 12 (first full sentence):

“Also, the limitation in claims 19 and 20 that the shifting of the upper tray relative to the lower tray is a ‘short distance’ (for nesting) it is believed unnecessary that the invention does not relate to the distance that shifting takes place.”

Therefore, appellants' counsel in attempting to obtain the claims of patent '535 expressly stated that the invention does not relate to the distance that the shifting takes place. However, in their brief, and in attempting to distinguish the claims of '535 from the prior art Faulkner patent (which, presumably was not known at the time of the prosecution of '535) plaintiffs assert that there *is* significance to the fact that Faulkner shifts 180° in order to nest an upper receptacle into a lower receptacle.

In any event, the important and paramount factor here is that neither claim 19 nor 20 of the '535 patent are limited in any manner to a *rotational* shift or to a *linear* shift, or to any particular amount of shifting, when the upper receptacle is to be nested into the lower receptacle.

Once it has been found that the claims of a patent are broad enough to read on the prior art, they cannot be saved by adding limitations impliedly, such as the limitation pertaining to the amount of shift or the direction of shift, if such limitations do not expressly appear in the claims. *Briggs and Stratton Corp. v. Clinton Machine Co. Inc.*, Court of Appeals, Eighth Circuit, 114 U. S. P. Q. 438, 440; 247 F. 2d 397 (1957) :

“We find no error in that conclusion and when we turn back to the theory of invention and patentability here contended for, we find it to be made without merit. The claims were made broad enough to cover an engine element produced by either kind of casting which resulted in certain advantages in use, and when it is found as in this case, that such elements in internal combustion engines were old . . . the patent cannot be saved by asserting limits to the claim not contained in them . . .”.

Likewise, the District Court of the Northern District of Illinois stated in the case of *Simmons Co. v. Sealy, Inc.*, December 18, 1957, 116 U. S. P. Q. 312, 314, 157 F. Supp. 1 :

“Simmons cannot be permitted to contract the scope of its claims . . . for the purpose of validity and to expand them for purposes of infringement.”

Appellants' expert witness Townsend testified [R. 303-307] that certain differences, in his opinion, existed between the structure disclosed in the prior art Faulkner patent and the purported invention defined in claims 19 and 20 of Lockwood '535. These differences concern the vertically extending clearways defined in claim 19, for example, and the fact that the upper and lower support portions of Faulkner are not vertically aligned. Mr. Townsend also testified [R. 305] that Faulkner did not show like parts of the two nested receptacles in nested registration.

In this respect, it should be pointed out that in order for a claim of a patent to be held valid, it must be shown that the invention defined in the claim represents a degree of difference which amounts to a patentable invention. As stated in the *Great Atlantic & Pacific Tea Co. v. Supermarket Equipment Corp.* case in the Supreme Court 340 U. S. 147 (1950); 87 U. S. P. Q. 303, 307:

"It was never the object of those laws to grant a monopoly to every trifling device, every shadow of a shade of an idea, which would naturally and spontaneously occur to any skilled mechanic or operator in the ordinary progress of manufacture . . . It embarrasses the honest pursuit of business with fear and apprehensions of concealed means and unknown' liabilities to law suits and vexatious accountings for profit made in good faith. (Citing with favor Mr. Justice Bradley in *Atlantic Works v. Brady*, 107 US 192, 200.

The standard of patentability is a constitutional standard; and the question of validity of a patent is a question of law . . . The court now

recognizes what has long been apparent in our cases: that it is the 'standard of invention' that controls, and is present in every case where the validity of a patent is in issue. It is that question which the court must decide . . . The attempts through the years to get a broader, looser conception of patents than the Constitution contemplates have been persistent. The Patent Office, like most administrative agencies, has looked with favor upon the opportunity which the exercise of discretion affords to expand its own jurisdiction . . .”.

This point was also raised in *Borkland v. Pedersen et al.*, C. A. 7 (1957), 244 F. 2d 501, 113 U. S. P. Q. 401, 402:

“We have examined all the prior art submitted, including documentary and oral evidence . . . From a consideration of all this prior art we think it clear that each element . . . (claimed) . . . was within the teachings of the art . . . Therefore, he did not achieve invention unless in combining these old elements, he produced a new result . . . We think, after examining the record, that to upset the finding of no invention is unjustified in view of the provisions of Rule 52(a) of the Rules of Federal Procedure. It is clear, we think, from the record, that plaintiff fell short of proof of a patentable invention . . . We agree with the trial court that no patentable invention exists . . . that any proved increased facility of operation does not rise to the statute of invention, and that no new and surprising result over the earlier art shown,—at most of such character as to impel a conclusion of patentable invention.”

The fact remains, therefore, that Lockwood in patent '535 was not the first to invent a receptacle which is capable of nesting or stacking without movable parts, or which may be stacked and nested in a manner such that each receptacle is in exact vertical registration with the next lower, or next upper, receptacle; all these features being shown in the prior Faulkner Patent. The mere fact that claim 19 of Lockwood patent '535 may specify upper support points vertically above lower support points, or like elements in vertical registration, is believed non-essential to the functioning of the claimed combination. The required end result, that is, vertical registration between stacked and nested baskets, is achieved in both Faulkner and in the latter Lockwood patent '535.

Moreover, an examination of the structure of the prior art Faulkner receptacles reveals that the "clearways" recited in claims 19 and 20 of Lockwood '535 *do* exist in the Faulkner structure, because such clearway are *essential* if the Faulkner receptacles are to nest, as they do.

As noted, any differences between the claimed combination of claims 19 and 20 of Lockwood Patent '535 and the Faulkner receptacle, asserted to exist by plaintiff's expert Mr. Townsend in his rebuttal testimony, are minor in nature, if they exist at all, and certainly do not fulfill the legal requirements that the claimed structure of Lockwood '535 must represent a patentable invention over the prior art Faulkner structure.

Point 4.

Plaintiffs contend that the Lockwood '535 Patent is not anticipated by the prior Blom Patent 2,684,766,

Defendants' witness Wilson testified that the receptacles marked Exhibit J were construed in accordance with the teachings of the prior art Blom Patent 2,684,766 [R. 210, 211]. Wilson also testified that the receptacles Exhibit K were also construed in accordance with the teachings of the Blom patent, with the exception that the "clearways" in Blom were slanted, rather than being straight up and down [R. 222, 223]. This position was not challenged by plaintiffs. The introduction of Exhibit K was objected to by plaintiffs [R. 220, 521], but was admitted [R. 221, 521] for purposes of illustrating the testimony of defendants' expert witness Robbins. Robbins testified that, in his opinion, the mere slanting of the clearways of the Blom structure would not amount to invention. The following testimony appears at [R. 240, 241]:

"Q. Based on your knowledge of the Blom patent, what differences do you find in Exhibit K?

A. The Exhibit K differs from the structure shown in the Blom patent on sheet 1 only in that the slots are slanted.

Q. In your opinion, as a patent solicitor, would such a change represent a patentable improvement over the receptacles shown in the Blom patent?

A. No, it would not. I would advise a client under those circumstances that it would be impossible to obtain a patent for such a deviation over the Blom structure as shown in the Blom patent on the first page."

Therefore, the reading by Robbins of claim 19 on the structure of Exhibit K [R. 240-246], and his reading of claim 20 of Lockwood '535 on Exhibit K [R. 252-256] carries the conclusion that claims 19 and 20 likewise did not distinguish patentably over the prior art Blom patent, and are therefore invalid.

It should be pointed out that the District Court did not actually hold the claims 19 and 20 of the Lockwood patent '535 invalid. The Court discussed the validity of the Lockwood '535 patent at pages 13-16A of the Memorandum Opinion [Record, Volume 1]. After discussing the question of validity in detail, the Court came to the conclusion that:

“In any event, the most that can be said is that any ‘invention’ in '535 must reside in the specific structure of its particular receptacles and not in the art or the article itself. In other words, '535 may be invalid as an ‘improvement’ patent, assuming it possesses the requirements of patentability, by its new, useful combination of the several parts of which it is composed, or by a modification of the devices which enter into its construction . . .”

The Court concludes at page 16A, however, that:

“In view of this conclusion, already applied to the infringement issue, it is not necessary to decide, whether, thus construed, '535 is, nevertheless invalid in view of the prior art shown in Faulkner and Blom.”

Point 5.

Appellees in this cross-appeal urge error in the above conclusion of the District Court, and assert that the mere fact the Court found non-infringement of the '535 patent by defendants, does not relieve it from the duty of finding invalidity with respect to claims 19 and 20. See, for example, *Hawley Products Co. v. U. S. Truck Co., Inc.* (C. A. 1), 259 F. 2d 69, 118 U. S. P. Q. 424, 429:

“ . . . in *Altvater v. Freeman*, 319 US 359 (1949), the Court held that although a decision of non-infringement finally disposed of a bill and answer, it did not dispose of a counterclaim which raised the question of the validity of the patent in suit . . . the law since the *Altvater* case is settled that a court retains jurisdiction to hold a patent invalid even after it had been found not infringed . . . of the two questions of validity and infringement ‘validity has the greater public importance’ *Sinclair Co. v. Interchemical Corp.* 325 US 327, 330 (1945), for it is of greater interest to the public that an invalid patent should not remain in the art as a scarecrow . . .”.

For the reasons discussed above in conjunction with Points 3 and 4, and as amply demonstrated during the trial, it is believed that claims 19 and 20 of the Lockwood patent are invalid as failing to define patentable novelty over the prior art Faulkner patent and over the prior art Blom patent.

Point 6.

Plaintiffs contend that Exhibit 9 infringes claims 21-28 of the '535 Lockwood patent.

As stated in Finding of Fact 21:

“Claims 21 through 28, inclusive, being dependent upon claim 20, contain by reference all the limitations of claim 20.”

It follows, therefore, that since claim 20 is not infringed by the Exhibit 9, the dependent claims 21-28, likewise, cannot possibly be infringed.

In addition to the above considerations, claims 21-28, as brought out by the testimony of plaintiff's expert Mr. Townsend [R. 142-151], as well as the statements contained in the file history of patent '535 [Ex. 10] all clearly indicate that these dependent claims are directed to embodiments disclosed in the Lockwood patent '535 which are nested by a rotational shifting movement and which are dissimilar in structure and in mode of operation from the receptacle Exhibit 9.

It is also pointed out that claim 20 was added to the application which resulted in the '535 patent by an Amendment dated May 26, 1949 [pp. 60-62 of Ex. 10]; and that claims 21-28 were added by an Amendment dated November 3, 1959 [pp. 66-73 of Ex. 10]. These amendments are added *after* photographs of Exhibit 9, and the charged receptacle Exhibit 9 itself, were actually in the possession of appellants' attorney, and in a specific attempt to cover Exhibit 9 [See Mr. Lockwood's testimony R. 95-97]. As evident by the file history of patent '535 [Ex. 10] the claims 20-28 were added after the receptacles Exhibit 9 were in posses-

sion of Lockwood's attorney. It is obvious that claims 20-28 were drawn, *not* "to particularly point out and distinctly claim" the *Lockwood* invention as required by the United States Code (35 U. S. C. 112); but to attempt to depart from the Lockwood invention and cover the subsequently appearing independent Wilson invention Exhibit 9.

A similar situation was considered by the District Court of Western Pennsylvania in the case of *Galion Iron Works & Mfg. Co. v. Beckwith Machinery Co.*, 25 F. Supp. 73, 74, 38 U. S. P. Q. 90 (affirmed on appeal 105 F. 2d 941, 42 U. S. P. Q. 209). In that case, the Court quoting with favor Mr. Justice Adley in *Chicago Northwestern Railway v. Sales*, 97 U. S. 554, 563, 24 L. Ed. 1053, stated:

"As we consider this patent we note that all the claims sued upon were added by amendment long after the application for patent was filed If in the meantime, other inventors have entered the same field, we have a case of possible intervening rights which cannot be appropriated by the patentee, merely by amending his claim

"The law does not permit such an enlargement of the original specification, which would interfere with other inventors who have entered the field in the meantime, anymore than it does in the case of reissue of patents Courts should regard jealousy and disfavor any attempts to enlarge the scope of an application once filed The effect of which would be to enable the patentee to appropriate other inventions made prior to such alterations"

Point 7.

The plaintiffs (appellants) assert that Exhibit O infringes claims 20-23 and 25 of the '535 patent. This assertion controverts Findings of Fact 22 and 23; and Conclusions of Law 7-9.

For the reasons discussed above with respect to Exhibit 9, Exhibit O likewise clearly does not infringe the '535 patent. As conceded in plaintiffs' brief (page 46), even their witness Mr. Townsend had difficulty in bringing Exhibit O under the definition of the claims of patent '535. He found it necessary to give a broader reading to the "clearway" clause of claim 20 [R. 216]. He also suggested that the "doctrine of mechanical equivalents" should be applied [R. 612, 614]. He also found a lengthwise dimension for Exhibit O [R. 629], even though the Exhibit does not have any ends, and asserts that the dimension is, therefore, "infinite"! But such considerations would require a broad interpretation of claims 20-23, 25 of the '535 patent, to say the least. However, as pointed out in the above cited cases, the conditions are such that the claims of the '535 patent are *not* entitled to a broad interpretation.

Reissue Patent Re. 24,731.

It should be noted, at this point, that the District Court held that claim 7 of the Reissue Patent Re. 24,731 is invalid [p. 21 of the Memorandum Decision, Record Volume 1], on the basis that "not only that no error was shown as a basis for the reissue, but also that the original patent '936, containing exclusively embodiment so designed and constructed that nesting could be accomplished by tilting manipulation only, did not show an intention to include a manipulation by horizontal,

lateral shift manipulation that could be accomplished only by a different means of design and structure than those actually shown in the drawings and specifications.”

Point 8.

It is defendants' contention that not only is claim 7 of the Reissue Patent '731 invalid, but that the *entire* reissue patent is invalid, and not infringed.

A. Invalid for Lack of "Error".

The entire Reissue Patent '731 is invalid in that it does not fulfill the requirements of the Reissue Statute 35 U. S. C. 251 (January 2, 1953).

The wording of the statute is clear :

“When any patent is, through error without any deceptive intention, deemed wholly or partly inoperative or invalid, by reason of defective specification or drawings, or by reason of the patentee claiming more or less than he had a right to claim in the patent, the Commissioner shall . . .”

The inventor Lockwood, as is apparent in the Oath on file in the file history of the Reissue Patent '731 [Ex. C-7] did not even aver error. Indeed, plaintiffs' counsel admitted in open court that there was no error, and made the surprising assertion that the law does not require error.

Plaintiffs' counsel Mr. Baldwin stated [R. 485-485A]:

“I should like to read a little farther. I am quoting from Section 251 under which reissue patents are granted. ‘Whenever any patent is, through error, without any deceptive intention, deemed wholly or

partly inoperative or invalid, by reason of a defective specification or drawing' and I will hesitate for just a moment to indicate that there has been no change in the specification or drawing. Quoting again: 'or by reason of the patentee claiming more or less than he had a right to claim in the patent, the Commissioner shall, under surrender of such a patent,' and so forth 'grant the reissue patent' and the last clause of that paragraph is: 'No new matter shall be introduced into the application for reissue.' Now, note that language, 'by reason of the patentee claiming more or less than he had a right to claim in the patent.' *That doesn't call for any error, your Honor, merely that he has found out that he claimed more or less than he had a right to claim through inadvertence, accident or mistake.*" (Italics added.)

As to counsel's admission that there was no error in the original patent; as to his contention that error is not required, and that a reissue patent may be secured merely to broaden claims and to embrace different inventions *even where there is no error*; this is not the law. See, for example, *Gearhardt v. Kinnaird* (District Court Kentucky), 162 F. Supp. 858, 864 in which the court stated:

"The rights to a reissue is exceptional and is given only to those who come clearly within the exception . . . The creation of a monopoly should be with caution . . . it must affirmatively appear in the case on a reissue patent, not only that the state of the art permitted a broader claim, but that failure to get it was solely due to inadvertence . . . When

the patentee has once declared himself he is bound by the claims and drawings set forth in the application unless he can bring himself within the provisions of 35 USCA Section 251 which provides for the reissue of defective patents. In order for the patentee to be entitled to a reissue it must appear that the application for reissue contains no new matter and is made only because of *error* (the underscoring appears in the original citation) in the original application and is without any deceptive intention . . . A reissue can be granted only where there is evidence that the new claims were made or brought about by accident, inadvertence, or mistake . . . in the light of the whole record it is not an unreasonable deduction that the application (for reissue) 'was not so much to correct an error' in the original application but to inject an item which was wholly absent in the original patent; an item which set forth an invention otherwise lacking."

In this Circuit there is the case of *Riley v. Broadway-Hale* (C. A. 9, 1954), 217 F. 2d 530:

"It must appear on the face of the original patent that the matter covered by the reissue was intended to have been covered and secured by the original (citing cases), the broader claims of the reissue must be more than merely suggested or indicated in the original patent (citing *U. S. v. Carbide*, 315 U. S. 668) as observed in that case 'It is not enough that an invention might have been claimed in the original patent because it was suggested or indicated in the specification.'"

Another Ninth Circuit case, *Kalich et al. v. Paterson Pacific Parchment Co.* (C. A. 9, July 3, 1943), 137 F. 2d 649, 652:

“In regard to the reissue patent, irrespective of the matter of invention, the question is whether in the light of the disclosures contained in both patents, the reissue covers the same invention. It must be apparent from the face of the instrument that what was embraced in the reissue was intended to have been taught and secured by the original. The invention must have been shown in the original patent. A reissue patent that broadens the claims to cover a new and different combination is void even though the result attained is the same as that brought about by following the process claimed in the original patent (citing cases).”

It is defendant's contention, and plaintiff's free admission, that there was no error in the original patent. Error must be shown to warrant the issuance of a valid reissue patent. Furthermore, the claims of the Reissue Patent '731 attempt to cover a different invention than that claimed in the original patent. This leads to the inescapable result that the *entire* reissue patent is invalid, not merely a particular claim therein. It is to be noted that the courts in the decisions cited above found, not that any particular claim of the reissue patent was invalid, but that the entire reissue patent was invalid.

B. Invalid Due to Prior Sale.

Furthermore, in the request for admissions (Nos. 1 and 2) [Ex. C5] defendants have admitted that in excess of 80,000 containers covered by claim 7 of the Lockwood Reissue Patent Re. 24,731 have been sold by

the plaintiffs prior to January 12, 1958. The application for Reissue Patent Re. 24,731 was filed January 12, 1959.

Therefore, the receptacles coming under the coverage of claim 7 of Reissue Patent '731 were on sale more than one year prior to the filing of the reissue application. This, under the authority of the *Crane Packing Co. v. Spitefire* decision, Court of Appeals, Seventh Circuit, 276 F. 2d 271, 274 (certiorari denied) invalidates the Reissue Patent '731. In that case the claims of a reissue patent were held invalid under 35 U. S. C. A. Section 102 (b) because the device was on sale and in use more than one year prior to the filing of the reissue application.

C. No Infringement.

The District Court found that, not only is claim 7 of the Reissue Patent '731 invalid [Conclusion 7], but the claim 7 is not infringed by the receptacle Exhibit 9 [Conclusion 13].

Preliminarily, note that none of the embodiments disclosed in the Reissue Patent '731 were ever used commercially; the commercial sales noted above were a different type of container not disclosed in the Reissue Patent '731, but covered by claim 7 thereof. The fact of no commercial use was brought out by defendants' interrogatories to plaintiffs (Nos. 16-19) [Ex. M]. Plaintiffs stated in their response filed July 28, 1961 [Record Volume 1], that none of the embodiments illustrated in the Reissue Patent '731 have ever been made or sold.

For the above reason, the Reissue Patent '731 is a mere paper patent, and claim 7 must be given a limited application, and the claim must be construed in a most restricted manner. This was brought out in the *Thompson v. Westinghouse* case (*supra*) and also in the *Glen-denning v. Mack* case (*supra*). It has been established by Mr. Robbins' testimony [R. 505-508], and it may be further established by an examination of the Reissue Patent Re. 24,731, that all the embodiments shown and described in the reissue patent rest by means of a "rocking" or "tilting" action. This was also pointed out on page 17 of the Opinion of the District Court [Record Volume 1]. This operation is distinctly different from the lateral shifting operation of Exhibit 9. There is, therefore, no identity of invention between Exhibit 9 and the claim 7 of the Reissue Patent, and therefore no infringement of claim 7. See, for example, *Simmons Co. v. A. Brandwein Co.*, 256 F.2d 440, 448:

"To constitute identity of invention and therefore infringement, not only must the results attained be the same, but in the case the means used for its attainment is a combination of known elements, the elements combined in both cases must be the same and combined in the same way so that each element shall perform the same function . . . Where a device is so changed in principle from a patented article that it performs the same or similar function in a substantially different way . . . the doctrine of equivalents may be used to restrict the claim and defeat patentee's action for infringement."

See also the following Ninth Circuit cases:

Keymart v. Printing Arts Research (C. A. 9),
201 F. 2d 624;

Grant v. Kopppl (C. A. 9), 99 F. 2d 106, 110;

McRoskey v. Braun Mattress Co. (C. A. 9), 107
F. 2d 143, 147.

The claimed elements of claim 7 of the Reissue Patent Re. 24,731 are not to be found in Exhibit 9 [R. 515-518]. Claim 7 recites at column 5, line 40 *et seq.*, for example:

“said bottom load supporting part and upper edge parts and side parts include upper tiering support members rigidly connected with said upper edge and side parts”.

As pointed out by Mr. Robbins [R. 516], in Exhibit 9, the upper tiering support members are formed by an endless wire which extends around the periphery of the receptacle, and these members are not included in “said bottom load supporting part” as specified in claim 7 of the reissue patent. Furthermore, as Mr. Robbins pointed out [R. 516], claim 7 of the reissue patent specified (column 7, line 3 *et seq.*):

“said bottom load supporting bar and upper edge parts and side parts including lower tiering support members rigidly connected with said side parts and said bottom part”.

In Exhibit 9, on the other hand, the lower tiering support members are formed by individual wire loops [R. 516] which extend across the bottom of the receptacle. These lower tiering support members of Exhibit 9 are not “rigidly connected with said side parts” as required by claim 7 of the reissue patent. In addition, and as

also pointed out by Mr. Robbins [R. 516], the lower tiering support members of Exhibit 9 are not included in “said . . . upper edge parts and side parts” as also required by claim 7.

In addition, claim 7 of the reissue patent recites at column 7, line 14 *et seq.*:

“there being a clearway provided between said bottom load supporting part and upper edge parts and side parts downwardly from each of said upper support members . . .”.

As brought out in Mr. Robbins’ testimony [R. 516, 517], and as is evident from an examination of Exhibit 9, the only “clearway” in Exhibit 9 extends down from the upper tiering support members, and such “clearway” stops before it reaches the lower tiering support members. This, as mentioned previously, is because bars 10 of Exhibit 9 are inserted in the spaces to interfere with normally interfering parts and to stop the downward movement of an upper receptacle as it is nested into a lower receptacle.

There is, therefore, no “clearway provided between said bottom load supporting part . . . from either of said upper support members” in Exhibit 9, as required by claim 7.

In addition, there is no “clearway” in Exhibit 9 “provided between said bottom load supporting part and upper edge parts and side parts . . .” as required in claim 7 of the reissue patent. Claim 7 of the reissue patent also specifies in column 6, line 17, with reference to the above discussed clearways, that the clearways are “enterable by the corresponding lower support member of an upper like receptacle in like orientation only after

manipulation . . .”. The specification in the Reissue Patent Re. 24,731 forces the recitation in claim 7 “only by manipulation” to be construed as a rocking or tilting motion.

“Claims may not cover more than the patentee’s invention and cannot be given a construction broader than the actual teachings of the patent as shown by the specification and drawings.” *Minneapolis-Honeywell Co. v. Midwestern Instruments*, District Court N.D. Illinois; E. Div., 188 F. Supp. 248; 127 U. S. P. Q. 149, 151 (1960).

On the issue of infringement of claim 7 of Reissue Patent '731, the District Court stated as follows [Opinion pp. 17-19 Transcript Volume 1]:

“Plaintiffs contend that Banner’s receptacle, Ex. 9, the accused article, infringes Claim 7 of the reissue and produced expert testimony to the effect that the Claim reads on Ex. 9.

“Defendants, on the other hand, introduced expert testimony to the effect that Claim 7 does not read on Ex. 9 in three main particulars.

“First, according to defendants’ expert testimony there is not found in Ex. 9 the limitation of Claim 7 (Col. 5 line 40) concerning bottom load supporting part and upper edge parts and side parts including upper tiering support members rigidly connected with said upper edge and side parts, nor the limitation (Col. 6 line 3) concerning bottom load supporting part and upper edge supporting parts and side parts including lower tiering support members rigidly connected with side parts and bottom.

“Defendants’ testimony was to the effect that these limitations are not found in Ex. 9 because its upper tiering support members are formed by an endless wire extending around the periphery of the receptacle, the upper tiering support members *not* being included in the bottom load supporting part as required by Claim 7 and, further, because its lower tiering support members are formed by individual wire loops extending across the bottom of the receptacle not being rigidly connected with side parts and not being included in the upper edge parts and side parts as required by Claim 7.

“Next, according to defendants’ expert testimony, there is absent in Ex. 9 the ‘clearway’ required by Claim 7, in much the same manner as required by Claim 19 of Lockwood ’535 already discussed.

“Thirdly, according to defendants’ expert testimony, there is not to be found in Ex. 9, the limitation implied in Claim 7 for upper and lower tiering support members of the type shown in all drawings and specifications nor is there found in Ex. 9 the tilting manipulation implicit in those drawings and specifications.

“The Court, applying narrow, rather than liberal construction, for reasons hereafter to be set forth, concludes that the testimony of defendants’ expert should be accepted on all three issues, and there is, therefore, no infringement of the reissue patent by Ex. 9.”

Therefore, claim 7 of the Reissue Patent ’731 does not cover Exhibit 9, and that Exhibit 9 does not infringe that claim.

Conclusion.

The Reissue Patent Re. 24,731 relates to receptacles so constructed that they may be either nested one within the other, or alternatively, may be tiered one atop the other, the construction being such that to move from a tiered to a nested position, the top receptacle is raised and moved laterally; then, by a tilting and rocking manipulation, the lower support portions of the upper receptacle are swung underneath the upper support portions of the lower receptacle, whereupon the upper receptacle may be dropped into nested position.

Like the reissue patent, the Patent '535 also relates to receptacles which may be nested one within the other, or which may be alternatively tiered one atop the other. The receptacles of patent '535 are characterized by the fact that, when tiered, the bottom of the upper receptacle lies inside the top of the lower receptacle. The receptacles of patent '535 are brought from tiered to nested position by raising the upper receptacle, and shifting it slightly horizontally and laterally beyond and around the support points, and into a clearway for nesting within the lower receptacle.

None of the receptacles or baskets disclosed in either the reissue patent or in patent '535 have ever been produced for commercial use. For this reason, the claims of both these patents must be given a limited interpretation.

Exhibit 9 was conceived and constructed by Banner's engineer Wilson without any knowledge of the Lockwood receptacles disclosed in patent '535 which, at the time of Wilson's invention [Ex. 9] was still pending in the Patent Office.

In April 1959 while the patent application which matured into patent '535 was still pending, Lockwood obtained a sample of Banner's newly conceived receptacle, Exhibit 9, and forwarded the same to Cleveland, Ohio, where it was placed in the hands of his Patent Attorney. Thereafter, there were added to the patent application, the claims which ultimately matured as patent claims 20-28 of the patent '535.

Claims 19 of '535 contains the limitation "the dimensions of the lower part of one tray lying inside the dimensions of the upper part of a like tray". The receptacle Exhibit 9 is constructed so that, when tiered, the lower part of an upper receptacle does *not* lie inside the dimensions of the upper part of a lower receptacle.

Claim 19 of '535 contains the further limitation that there is a "generally vertically extending clearway from directly above each lower point of support of an upper receptacle extending upwardly to the upper points of support of a lower receptacle when two like receptacles are nested." In Exhibit 9, when the two receptacles are nested, the space between the lower point of support of an upper receptacle and the upper point of support of a lower receptacle is interrupted by a bar [marked point 10 on Ex. 9]

Like claim 19, claim 20 of patent '535 is also limited by the relative dimensions between upper and lower receptacles by reciting that "the dimensions of the upper and lower parts of said receptacles permitting the lower part of an upper receptacle to enter vertically downward into the upper part of a lower like receptacle". The receptacles Ex. 9 do not meet this structural limitation, because the lower part of an upper receptacle does not

enter vertically downward into the upper part of a lower like receptacle, but instead rests fully atop the lower receptacle.

It follows, therefore, that claims 19 and 20 of patent '535 are not infringed by either Ex. 9 or Ex. O, because the express requirement in the "dimensions" clause of these claims, and the express requirement in the "clearways" clauses, are not to be found in either Ex. 9 or in Ex. O. Claims 21-28, inclusive, being dependent upon claim 20, contain by reference all the limitations of claim 20, and likewise, are not infringed.

The idea of tierable-nestable receptacles or baskets having no moving parts, which may be changed from tiered to nested position by a lateral shift into nesting clearways, was not new with Lockwood, this being shown, for example, in the prior art Blom patent; nor was the idea of receptacles which both tier and nest in vertical alignment, this being shown, for example, in the prior art Faulkner patent.

Neither in the reissue Oath, nor in the reissue prosecution of the Reissue Patent Re. 24,731, nor in the showing made in this case, was there any averment or showing of error as a basis for the reissue patent. There was, in fact, no error in the filing, prosecution or issue of the original patent 2,782,936, which was reissued as the Reissue Patent Re. 24,731 here in suit.

The original patent '936 disclosed and claimed exclusively receptacles or baskets so designed and constructed that nesting could be accomplished only by a

tilting manipulation. There was no intention on the part of the patentee to include horizontal or lateral shift, for such could be accomplished only by a different means, design, and structure than those shown in the drawing and specification of the original patent '936.

The subject matter claimed in the reissue patent was in public use and on sale in the United States more than one year prior to the filing of the reissue application.

Claim 7 of the reissue patent requires that the bottom load supporting part and upper edge parts and side parts include upper tiering support members rigidly connected with said upper edge and side parts. The claim further requires that the bottom load supporting part and upper edge supporting parts and side parts include lower tiering support members rigidly connected with said side parts and bottom. This definition is not to be found in the receptacle Ex. 9, for the reasons discussed above. Moreover, the clearway requirements of claim 7 of the reissue patent are not to be found in Ex. 9, as noted above. In addition, the "manipulation" requirements of claim 7 should be interpreted as referring to the tilting or rocking motion taught by the patent, and not to other motions which were not contemplated or described in the patent.

For the above recited reasons, it is submitted that there is no error in the holding of the District Court that the patent '535 is not infringed by the receptacles Ex. 9 and O; and that there is no infringement of the Reissue Patent Re. 24,731.

As to the Declaratory Judgment action, a justiciable controversy existed and does exist between the parties and defendants' Counterclaim was well taken.

In addition, as cross-appellants, defendants respectfully urge that:

A. The claims 19 and 20 of the patent '535 are invalid; and

B. The entire reissue patent Re. 24,731 is invalid.

Respectfully submitted,

KEITH D. BEECHER,

Attorney for Appellees.

Certificate of Counsel.

I certify that, in connection with the preparation of this brief, I have examined Rules 18 and 19 of the United States Court of Appeals for the Ninth Circuit, and that, in my opinion, the foregoing brief is in full compliance with those rules.

KEITH D. BEECHER.

*See also
Vol. 3191*

No. 18160 ✓

**United States Court of Appeals
FOR THE NINTH CIRCUIT**

FRANK STRANGWAY,

Appellant,

vs.

UNITED STATES OF AMERICA,

Appellee.

On Appeal from United States District Court
Southern District of California
Southern Division

PETITION FOR REHEARING

RICHARD E. ADAMS
474 Spreckels Bldg.
San Diego 1, California

Attorney for Appellant

FILED

7-5 1963

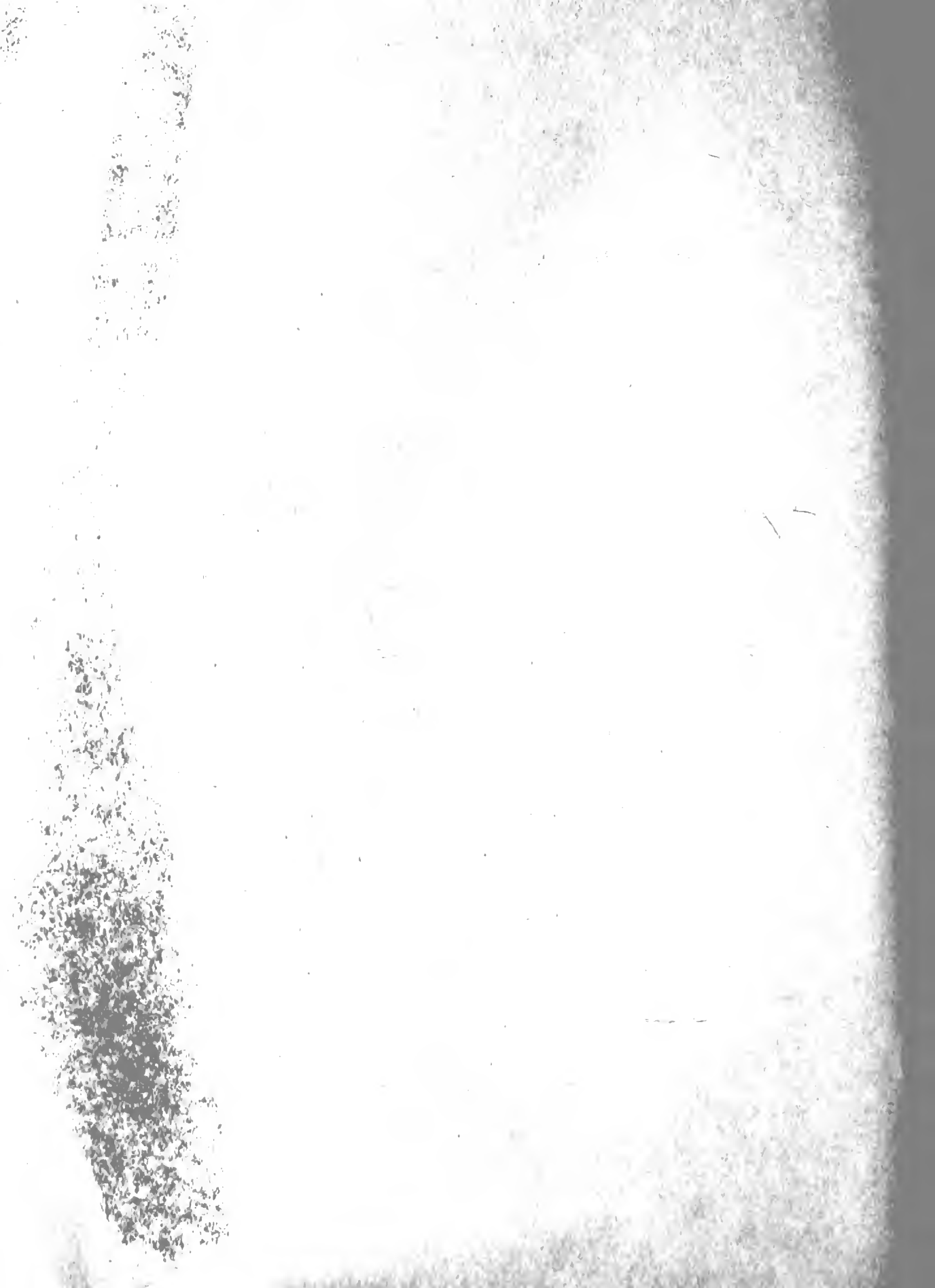

TABLE OF AUTHORITIES CITED

CASES

| | Page |
|--|------|
| Donaldson vs. US, 9 Cir. , 248 F. 2d 364, 367 | 1 |
| US vs. Kawakits, S. D. Cal. , 96 F. Supp. 824, 855-856 | 2 |



IN THE UNITED STATES COURT OF APPEALS

FOR THE NINTH CIRCUIT

No. 18160

FRANK STRANGWAY,

Appellant,

vs.

UNITED STATES OF AMERICA,

Appellee.

PETITION FOR REHEARING

Appellant, FRANK STRANGWAY, hereby petitions the Honorable United States Court of Appeals for the Ninth Circuit, for a rehearing in the above entitled matter and bases his petition on the following grounds and circumstances:

Appellant earnestly contends that the court should evaluate the evidence in this case in order to determine whether there was sufficient evidence to support the verdict.

It is appellant's belief that the case of Donaldson vs. US, 9 Cir. , 248 F. 2d 364, 367 is not in point in that in the Donaldson case evidence adduced to support the convictions was not transcribed and made a part of the record on appeal, whereas in the instant matter, appellant was convicted on only one count, and all of the evidence offered in support of that count was transcribed and made a part of the record.

Appellant also respectfully requests the court to reconsider its ruling in respect to appellant's contention that the verdict was coerced.

The record discloses that no opportunity was given appellant to object to the instruction in question until after the jury had retired. (Rep. Tr., p. 418, ll. 3-25, p. 420, ll. 1-12).

The trial court gave the instruction without discussing it with appellant prior to the commencement of the reading of the instructions and immediately upon the conclusion of the instruction the jury was asked to once more retire.

However, on the merits, appellant would ask this court to review its opinion on the grounds that US vs. Kawakits, S. D. Cal., 96 F. Supp. 824, 855-856, is not identical with the instruction that appellant here questions in that, in the instant case the jury was asked to consider matters outside the evidence in arriving at a verdict and such instructions have been disapproved as shown by cases set forth in appellant's opening brief.

WHEREFORE, Appellant respectfully prays that a rehearing be granted in the above entitled matter.

RICHARD E. ADAMS

Attorney for Appellant

CERTIFICATE IN SUPPORT OF
PETITION FOR REHEARING

STATE OF CALIFORNIA)
COUNTY OF SAN DIEGO) ^{SS}

RICHARD E. ADAMS, being first duly sworn, deposes and says: That he is the attorney for the appellant, Frank Strangway, and that in his judgment the matters set forth in appellant's petition for rehearing are well founded and present a substantial question of law and that the petition for rehearing is not interposed for delay.

/s/ RICHARD E. ADAMS

Subscribed and sworn to before me
this 5th day of January, 1963.

HELEN JEAN TAFF
My commission expires March 21, 1964.

Notary Public in and for the
County of San Diego, State of
California



No. 18,172. ✓

*See also
Vol. 3191*

United States Court of Appeals
For the Ninth Circuit.

ROBERT S. GAYNOR and JANET STONE,
Appellants,

vs.

JAMES L. BUCKLEY, JULIAN N. CHEATHAM, ROBERT B. PAMPLIN, JOHN S. BRANDIS and GEORGIA-PACIFIC CORPORATION,

Appellees.

APPEAL FROM THE UNITED STATES DISTRICT COURT
FOR THE DISTRICT OF OREGON.

APPELLANTS' REPLY BRIEF.

SIDNEY L. GARWIN,
1501 Broadway,
New York 36, N. Y.

PETERSON, LENT & PAULSON,
300 S. W. Madison Street,
Portland 4, Ore.,
Attorneys for Appellants.

FILED

DEC 11 1932

FRANK H. SCHMID, CLERK



INDEX

| | PAGE |
|--|------|
| Statement | 1 |
| The requirement of stockholder consent | 1 |
| The scope of stockholder approval | 3 |

ARGUMENT

| | |
|--|----|
| I. Modification by the directors of the option agreement with Brandis was invalid for lack of stockholder approval | 6 |
| II. The ratification by the stockholders extended to the entire agreement | 14 |
| Conclusion | 16 |
| Certificate | 16 |

TABLE OF CITATIONS

Cases

| | |
|--|----------|
| Amdur v. Meyer, 15 A. D. 2d 425, 225 N.Y.S. 2d 440 (1962) | 8, 9, 10 |
| Beveridge v. N.Y.E.R. Co., 112 N. Y. 1, 19 N. E. 489 (1899) | 7, 8, 9 |
| Dudley v. Perkins, 235 N. Y. 448, 139 N. E. 570 (1923) | 7 |
| Gottlieb v. Heyden Chemical Corp., 33 Del. Ch. 82, 90 A. 2d 660 (Sup., 1952) | 12 |
| Gottlieb v. Heyden Chemical Corp., 33 Del. Ch. 377, 91 A. 2d 57 (Sup., 1952) | 12 |

| | PAGE |
|--|------|
| Petrishen v. Westmoreland Finance Corp., 394 Pa. 552, 147 A. 2d 392 (1959) | 11 |
| Texas Co. v. Z. & M. Independent Oil Co., 66 F. Supp. 957 (N.D.N.Y. 1945), aff'd 156 F. 2d 862 (2nd Cir. 1946) | 6 |
| Winkelman v. General Motors Corp., 44 F. Supp. 960 (E.D.N.Y. 1942) | 13 |
| Witherell v. Murphy, 147 Mass. 417, 18 N. E. 215 (1888) | 15 |

STATUTES

| | |
|-----------------------------|----|
| Cal. Civ. Code § 2310 | 15 |
|-----------------------------|----|

OTHER AUTHORITIES

| | |
|---|----|
| 1 A.L.I. Restatement of Agency 2d (1958) § 58 | 15 |
| 1959 Annual Survey of American Law-Business Organization, 35 N.Y.U.L. Rev. 613 (1960) | 12 |
| 2 Loss, Securities Regulations (2d ed., 1961) | 2 |

United States Court of Appeals For the Ninth Circuit.

ROBERT S. GAYNOR and JANET STONE,

Appellants,

vs.

JAMES L. BUCKLEY, JULIAN N. CHEATHAM, ROBERT B. PAMPLIN, JOHN S. BRANDIS and GEORGIA-PACIFIC CORPORATION,

Appellees.

APPEAL FROM THE UNITED STATES DISTRICT COURT
FOR THE DISTRICT OF OREGON.

APPELLANTS' REPLY BRIEF.

Statement

Two misconceptions permeate the factual narrative of both briefs submitted by the appellees and becloud the essentially simple issue of the case. These misconceptions are 1) that G-P's charter and the law of Georgia made stockholder consent here really unnecessary, and 2) that the stockholders did not ratify all the terms and conditions of the option. We address ourselves to these.

1. The requirement of stockholder consent.

Our main brief indicated our awareness that, under given circumstances, and as a question of the directors' power under those circumstances, the G-P board might have conferred the option without stockholder approval (PB 14, 34-35)*. We pointed out that the approval of G-P's stock-

* The following abbreviations will be used herein, in addition to those employed in our main brief:

PB —Brief of plaintiffs-appellants.

GPB—Brief of Georgia-Pacific Corporation, appellee.

IDB —Brief of individual defendants-appellees.

holders was necessary for the option here for only one reason, i.e., that the stock with which G-P intended to satisfy the option was to be listed on the New York Stock Exchange. This view is borne out by the proxy statement of G-P and by the testimony of both G-P's counsel and president (PB 7).

The appellees point to various other methods of satisfying the option without securing stockholder approval (GPB 12-16, IDB 6-8, 14-16). The stubborn fact, however, as we pointed out, is that, the G-P management utilized none of the asserted alternatives. Specifically—

a) G-P in fact did not utilize existing treasury stock to satisfy the option. It had none (PB 33).

b) G-P in fact did not proceed to acquire stock in the open market to satisfy the option (*id.*).

c) G-P in fact did not cancel the conditioned option and replace it with a new one (*ibid.*, 33-34).

d) G-P in fact did not seek a waiver from the Exchange of the requirement of stockholder approval.*

* Furthermore, under the terms of the Exchange Manual, G-P could not have received a waiver. According to the Manual it may be possible to obtain a waiver—

“ . . . where options are issued to an individual, not previously employed by the company, as an inducement essential to his entering into a contract of employment with the company.”
(R 19, lines 8-10)

The conditions were not met because 1) Brandis had been “previously employed by the company” (PB 3, 4); and 2) the option was not “an inducement essential to his entering into a contract of employment with the company”. This is clear from Brandis' deposition testimony (pp. 14-15) concerning the circumstances of the conferral of the option.

Because of its compactness, the paraphrase of the Exchange's requirements for a waiver set forth in 2 Loss, Securities Regulation (1961), quoted at GPB 15, does not fully reflect the conditions to a waiver as set forth in the Exchange Manual and quoted above.

G-P wanted to and did list the optioned stock. Given this objective, stockholder consent was a mandatory necessity, as mandatory as if it had been prescribed by statute or charter.

Furthermore, the requirement of consent supervened any statutory or charter provisions dispensing with consent. The Exchange Manual prescribes stockholder authorization "*regardless of whether or not such authorization is required by law, or by the company's charter*" (R. 18, lines 9-11, PB 8).

2. The scope of stockholder approval.

We pointed out in our brief that the stockholders had ratified the option agreement of February 7, 1956 with Brandis. The appellees assert (GPB 27, IDB 17-18) that the matter submitted to a vote of the stockholders was only the question of ratifying the action of the directors in conferring the option. This hairsplitting confuses the mechanics of the ratification with the substantive action that G-P A) was required to take, B) that it did take, and C) that it asserted it had taken. This substantive action was the approval of the February 7, 1956, option agreement with Brandis which had been authorized by the directors. This agreement contained the conditions which were later extended and thereafter waived.

A. The ratification, it is agreed, stems from the requirement of the New York Stock Exchange. With respect to the substantive action, the Exchange Manual states (R. 18, lines 5-11):

"The Exchange is of the view that issuance of options to directors, officers or key employees, entitling them to acquire securities of the company, should be authorized by stockholders. Accordingly, stockholders' authorization in respect of options issued to directors, officers or key employees will be a condition prerequisite to authorization of the listing of the optioned

securities, regardless of whether or not such authorization is required by law, or by the company's charter.

The Exchange's view is thus that the stockholders' authorization must be of the "issuance of options" or "in respect of options", rather than of the action of the directors in conferring them.

With respect to the mechanics of securing approval, the Manual states (R. 18, lines 12-16):

"Nature of Stockholders' Authorization Required: It will be acceptable, under Exchange policy, if stockholders give specific authorization for issuance of options to directors, officers or key employees; or if they approve a plan for issuance of options, or if they authorize issuance or reservation of securities for the satisfaction of such options; or take any other affirmative action implementing, or relating to, such options or plan; . . ."

This paragraph enumerates various *methods* by which stockholder authorization may be effected. But, as the Manual makes clear, these are only means to the end. The end at all times is the authorization of the option by the stockholders. This is the substantive requirement of the Exchange with which G-P here had to comply.

B) With respect to the substance of what was actually done by G-P's stockholders, it was conceded by G-P that the stockholders ratified the agreement of February 7, 1956. This was acknowledged by Mr. Pamplin, president and a director of G-P (PB 9):

"Q. When you sought the ratification of the stockholders, you sought the ratification of the terms of the option, didn't you, that was entered into, the terms of the option agreement that was entered into?

"A. I would say that's right." (T. 40)

That no stockholder may have availed himself of the opportunity to examine the option agreement at the meeting (GPB 29-30) is of less moment than the fact, as Mr. Pamplin testified, that on request a stockholder would have been afforded the opportunity (T. 40, PB 9), for it shows what it is that G-P conceived that the stockholders were passing upon.

C. With respect to what G-P itself asserted it had done, we noted in our main brief that subsequent to the stockholders' meeting, G-P filed with the S.E.C. and the Exchange, in a "current report" on Form 8-K, the full text of the option agreement, in response to an instruction that there be filed a copy of the text of the proposal submitted to a vote of the stockholders (PB 9-10). If, as the appellees now earnestly profess, the matter submitted to a vote of the stockholders was merely the grant of the option, without reference to the conditions of its continuing in force, there was no reason for filing the full text of the agreement.

G-P's brief here is utterly silent concerning the officially prescribed filing of the full text of the option agreement, and the significance of such filing for the appellees' contentions. The brief of the individual appellees (IDB 17-18), however, lists the 8-K Report among the documents which, the appellees contend,

" . . . establish that the option agreement was not submitted, that no reference was made to the conditions in paragraph 15, and that the submission was made for the purpose of securing ratification of the Board's action in granting the option *as described in the proxy statement.*" (Emphasis in original.)

Since the full text of the option agreement was filed in the 8-K Report, this statement is incomprehensible.

ARGUMENT

POINT I

Modification by the directors of the option agreement with Brandis was invalid for lack of stockholder approval.

In our main brief (pp. 20, *et seq.*) we cited various authorities, in the field of executive compensation and elsewhere, showing the paramount power of the stockholders with respect to corporate action authorized by them, and the lack of power of the directors thereafter to deviate from authorization thus conferred.

Corroboration of this view is further afforded by *Texas Co. v. Z. & M. Independent Oil Co., Inc.*, 66 F. Supp. 957 (N.D.N.Y. 1945). There, by an agreement of September 20, 1929, Z & M granted an option under which Texas could acquire all of its property. One of the methods of determining the price was to be an appraised fair value, the agreement setting forth standards of appraisal for the realty and for the personalties. On September 18, 1929 the Z & M directors had authorized the execution of the option agreement. By law stockholder approval was required, and on September 23, 1929, it was obtained.

In February, 1930, Z & M, without stockholder approval, agreed to a change in the prescribed method of appraising the personalties (66 F. Supp. at 961).

In 1944 Texas sought to exercise the purchase option, and Z & M asserted that the option agreement was invalid on various grounds. Concerning the February, 1930 change in the method of appraisal, Texas advanced a contention echoing that of the appellees here (66 F. Supp. 966):

“Plaintiff [Texas] urges that inasmuch as the resolution of the stockholders did not prescribe the manner

in which the properties were to be appraised or the standard of valuation to be used therein, such change was merely a change in detail which the stockholders left to the discretion of the officers of the company, and that such change was fully within the stockholders' authorization."

The court rejected this contention. Holding the modification invalid, the court stated (*id.*),

"Having exercised their authority under the stockholders' resolution, the officers had no further power. Their authority was exhausted. The power to execute and deliver a contract does not imply authority to modify it. The attempted modification of the option agreement of February, 1930 is ineffective. *Dudley v. Perkins*, 235 N. Y. 448, 139 N. E. 570 [1923]."

Neither side challenged this ruling on appeal, 156 F. 2d 362 (2d Cir., 1946), at 864, note 1, where the ruling of the district court was in other respects affirmed.

The case thus holds, in accord with our position, that where stockholder consent to an agreement is required and secured, the agreement may not thereafter be changed without their consent. No residual authority to change the agreement remains.

We may add that the ruling, especially in view of its reliance on *Dudley v. Perkins*, corroborates the position, advanced in Point III of our main brief (PB 38-42), that the law of agency prohibited G-P's directors from departing from the terms of the option agreement. The casual dismissal of this contention by the appellees (GPB 31, IDB 27) obviously is in error.

Appellees' principal reliance for their proposition that the extension and waiver here could be validly authorized by the directors without stockholder approval is on two cases, *Beveridge v. N.Y.E.R. Co.*, 112 N. Y. 1, 19 N. E.

489 (1899), and *Amdur v. Meyer*, 15 A. D. 2d 425, 225 N.Y.S. 2d 440 (1962). *But in both these cases, the directors' modifications were approved by the stockholders.* Despite extensive analysis of and quotation from the cases, both briefs of appellees overlook this fact.

Appellees' reliance on *Beveridge*, furthermore, is made possible only by their perpetuating the misapprehension which pervades their briefs throughout. They persist in ignoring the fact that the G-P board here, deliberately and with full awareness, followed a course of conduct which made resort to stockholder authorization essential "whether or not such authorization is required by law, or by the company's charter", as the Exchange Manual prescribes.

In *Beveridge*, there was no requirement of any sort that stockholder authorization be obtained for the tripartite agreement of May, 1879, under which New York's properties were leased to Manhattan. Legislation of 1839, the court held, had been construed to dispense with stockholder concurrence, 112 N. Y. 21-22, 19 N. E. 493-4. While the securing of such concurrence by the directors was held to be "a very proper and reasonable precaution to take," 112 N. Y. 24, 19 N. E. 495, it was not a condition to the validity of the method chosen to effectuate the directors' objective. Since the stockholder's initial concurrence there was thus legally gratuitous, the court after discussion concluded that stockholder concurrence in the later lease modification of October and November, 1881, was not necessary. 112 N. Y. 27, 19 N. E. 497. In view of the actual ratification there, however, the discussion was obviously not necessary to its decision.

While the *Beveridge* case thus proceeds in a factual and legal setting different in a basic respect from the present one, we may note a further factor rendering the language of the Court inapplicable to the present situation. A principal ground of the decision was that the obliga-

tion in suit did not run to the plaintiff individually, and that he therefore lacked standing to bring the action at all. 112 N. Y. 24-27, 19 N. E. 496.

Finally, as has been noted, even the 1881 modifications which the plaintiff challenged also received stockholder approval, at a meeting in January, 1882. 112 N. Y. 17, 19 N. E. 492. In the present case, the lack of stockholder approval for the modifications is precisely the gravamen of the suit.

It is of significance that while appellees seek to read into the *Beveridge* case a ruling that stockholder-approved action may be modified by directors without further stockholder action, the case has never been cited as authority for this proposition.

Amdur v. Meyer, 15 A. D. 2d 425, 224 N.Y.S. 2d 440 (1962), is made to support the appellees' position only by means of an utterly unwarranted interpolation by them into the court's opinion.

As was earlier noted, the directors' alteration of the terms of an option agreement was confirmed "by an overwhelming vote" of the stockholders. 224 N.Y.S. 2d 442. Since stockholder ratification had been given, there was no need for the Court to consider any contention that the modification was ineffective without stockholder ratification, and the court did not in fact pass upon it. The contentions of the complainants on which the court did pass were set forth in the opinion. The opinion said (224 N.Y.S. 2d 442-443):

"Respondents contend that the directors by the adjustment made a gift to the optionees which was not contemplated by the provisions of the original agreement. They submit that the directors under the guise of interpreting the agreement in fact amended the document. They argue that the action taken was a subterfuge because amendment of the agreement would

have presented tax problems and would have required revelation in proxy and annual statements.”

This was the sum total of the complainants’ contentions to which the Appellate Division addressed itself. It immediately proceeded to state (224 N.Y.S. 2d 443),

“We find no merit to respondents’ contentions in the light of the facts presented. Neither do we find it necessary to determine whether the 1958 action was an ‘interpretation’, ‘construction’ or ‘modification’ of the basic agreements . . .”

In our case, the individual appellees do not set forth the above-quoted contentions in their brief. Instead, they seek to give their own connotation to the conclusion of the Appellate Division by inserting a question raised by the *Amdur* complainants, but one to which the court did not address itself (IDB 22). The question put by the *Amdur* complainants was: After stockholder approval was obtained for the initial option plan,

“Could the directors thereafter, without action on the part of the stockholders or notification to them, amend the option agreements to provide additional benefits?” (Quoted at IDB 22).

After quoting this question, the brief of the individual appellees here proceeds to state (IDB 22),

“The Appellate Division reversed the lower court, directed judgment for the defendant and dismissed the complaint, saying (224 N.Y.S. 2d at 443):

“‘We find no merit to respondents’ contentions in the light of the facts presented. . . .’”

By interpolating the *Amdur* complainants’ question immediately before it recites the Appellate Division’s reversal and the quotation beginning “We find no merit to re-

spondents' contentions . . ." the individual appellees' brief makes it appear that the Appellate Division was rejecting the contention, posed by the quoted question, that the directors could not amend the option agreement without stockholder approval. But the Appellate Division passed on no such contention. The fact that the stockholders had approved the modifications rendered the question totally moot.

Indeed, the consent of the stockholders to the modification made the Amdur complainants resort to the extreme position that the plan amendment constituted "a gift to the optionees" (224 N.Y.S. 2d 442, quoted above, p. 9), which not even majority stockholder ratification could confirm (224 N.Y.S. 2d 444). The Appellate Division, holding that it was within the directors' competence to determine that in the light of the dilution of the optionees' stock interests, "the basic agreement did not convey the benefits the directors had originally intended to confer," (224 N.Y.S. 2d 443), concluded that there was no showing that the defendant-director was acting other than according to his best judgment, "which was subsequently confirmed by the stockholders" 224 N.Y.S. 2d 443. It held therefore that the action did not constitute a gift (224 N.Y.S. 2d 444). This is a far cry from the present case.

G-P (GPB 18) cites also *Petrishen v. Westmoreland Finance Corp.*, 394 Pa. 552, 147 A. 2d 392 (1959), but its relevance to the present situation is not evident. The case involved a departure by the board of directors from the terms of an agreement previously approved by the board of directors. It did not involve a departure by the board of directors from the terms of a corporate step ratified by stockholders, and certainly not from the terms of a corporate step for which stockholder ratification was required. According to the opinion, 147 A. 2d 394,

"This agreement was approved and ratified by *all* of the directors, who at that time also constituted *all*

of the corporation's stockholders." (Emphasis in original.)

The directors thereafter issued stock on terms not conforming to those in the agreement, and this action was sustained by the court.

Independent corroboration of this reading of the case appears in "1959 Annual Survey of American Law—Business Organization", 35 N.Y.U.L. Rev. 613 (1960), at 634:

"Another familiar statutory provision that no stock shall be issued 'except for money, labor done, or money or property actually received' has been interpreted by the Supreme Court of Pennsylvania not to invalidate the *directors'* promise at the time of employment, to issue stock in the future to a key employee, and later to waive a condition that the stock shall be issued only when the earnings of the corporation reach a certain level." (Emphasis added.)

It was a condition of "the directors' promise" that was waived, not the stockholders'. The case does not reach the problem with which we are here concerned, the power of directors to modify and waive stockholder-authorized action.

The attempts of the appellees to distinguish *Gottlieb v. Heyden Chemical Corp.*, 33 Del. Ch. 82, 90 A. 2d 660 (Sup., 1952), on reargument, 33 Del. Ch. 377, 91 A. 2d 57 (Sup., 1952), are without merit. Their effort is based upon the language of the opinion stating that at the time of the stockholders' meeting the option contracts had already been executed, and that as of that date

" . . . neither party alone could alter rights under the contracts . . ." 90 A. 2d 665.

This passage, the appellees claim, holds that, as to executed bilateral contracts, amendments could be made

only by agreement of both parties thereto, and they deny that the case holds that amendments by the directors and the optionees required stockholder approval (IDB 25, GPB 23).

That changes in executed option contracts require the consent of the optionees is elementary. But this was not the question before the court. The question, as we stated in our brief, was whether the stockholders' ratification was illusory because the directors had the power to amend, and it assumed the optionees' consent.

This question the court twice answered in the negative. See the discussion in appellants' brief (PB pp. 22-23). Appellees' error stems from their view that it was the directors who were one of the contracting parties, instead of recognizing that it was the corporation that is the party. Once this fact is recognized, the discussion in our brief shows that the directors could not amend on behalf of the corporation (even with the consent of an optionee) unless the amendment was approved by the stockholders. Any other construction of the court's opinion renders it meaningless.

In *Winkelman v. General Motors Corp.*, 44 F. Supp. 960 (S. D. N. Y., 1942), with respect to the stockholder-approved Managers Securities plan, the court did not say that the change in date, agreed to on behalf of General Motors by Mr. Sloan, would have been valid if the change had been approved by the board of directors. It specifically stated, as our brief pointed out (PB 25):

“If a change in date was desirable an amendment of the plan should have been submitted to the stockholders for their approval.” 44 F. Supp. 977.

The requirement of stockholder approval for bonus plan amendments in the *Winkelman* case, notwithstanding the reserved power of the directors to amend, was discussed in our main brief (PB 25).

On an analysis of all the cases, the appellees' as well as the appellants', it is clear that when stockholder ratification is a prerequisite to corporate action and is obtained, ratification is likewise required for any alteration or modification of such action.

POINT II

The ratification by the stockholders extended to the entire agreement.

Our main brief expressed the view that the stockholders' ratification of the option agreement was entire and included the ratification of the conditions under which the option would be extinguished (PB 37-38).

In response, the appellees first take the position that the ratification extended only to that portion of the agreement which conferred the option (IDB 18, GPB 26). They cite no authority for such partial ratification.

Apparently realizing the weakness of this position, they appear also to contend that the stockholders could not ratify a contract containing undisclosed conditions, and that consequently there was no ratification (IDB 18, GPB 30).

This position essentially asserts that the management was free to withhold terms of the agreement from the stockholders in seeking ratification; proceed to use the ratification for the purpose of obtaining a listing of the stock; attest to the S.E.C. in an 8-K report that the ratification covered the entire agreement; and then, in this case and for the purpose of justifying the modification of the terms of the agreement without stockholder approval, assert the management's own non-disclosure to demonstrate that there had been no initial ratification. They conclude from all this that no ratification of the later extension and waiver was necessary. They thus assert their own deliberate non-disclosure as conferring upon themselves greater powers than if they had fully disclosed.

This argument puts a premium on deliberate concealments by the management in order to enhance its own power vis-a-vis the stockholders. It should not be countenanced by a court of equity.

Appellees, in addition, ignore a familiar tenet of what constitutes the scope of authorization and ratification, both of which, as we have seen (PB 38), are governed by the same principles of law. Cf. Cal. Civ. Code, § 2310.

According to 1 A.L.I. Restatement of Agency 2d (1958) § 58:

“AUTHORITY TO MAKE UNSPECIFIED TERMS. Unless otherwise agreed, the specification of particular terms in an authorization to buy or to sell does not exclude authority to make additional terms not inconsistent with those prescribed, *nor terms which diminish the duties or increase the rights of the principal* beyond those specified.” (Emphasis supplied.)

See also:

Witherell v. Murphy, 147 Mass. 417, 18 N. E. 215, 216 (1888).

Thus, in the present case, the ratification of the 8-year option also ratified the conditions under which the option could be terminated sooner and G-P could supply less stock than the full option required. These conditions diminished the obligations of G-P and increased its rights, and the conditions were therefore embraced within the scope of the ratification. Thus the contentions of the appellees fall, because they are based upon the incorrect premise that in the absence of disclosure, the conditions were not ratified.

Conclusion

This is a case of first impression in this Court. We do not believe the Court should let stand a ruling which violates a fundamental right of corporate stockholders, and which sanctions a management device for increasing management power by means of non-disclosure to the true owners of a corporation.

The judgment below should be reversed.

December, 1962.

Respectfully submitted,

SIDNEY L. GARWIN,
1501 Broadway,
New York 36, N. Y.

PETERSON, LENT & PAULSON,
300 S. W. Madison Street,
Portland 4, Ore.,
Attorneys for Appellants.

SIDNEY L. GARWIN
Attorney

Certificate

I certify that, in connection with the preparation of this brief, I have examined Rules 18 and 19 of the United States Court of Appeals for the Ninth Circuit, and that, in my opinion, the foregoing brief is in full compliance with those rules.

Sidney L. Garwin

See also Vol. 3191

No. 18173 ✓

IN THE

United States Court of Appeals

FOR THE NINTH CIRCUIT

COAST METALS, Inc., a corporation,

Appellant,

vs.

WALL COLMONOY CORPORATION, a corporation,

Appellee.

REPLY BRIEF FOR PLAINTIFF- APPELLANT.

FILED

CHRISTIE, PARKER and HALE,

By ROBERT L. PARKER,

ANDREW J. BELANSKY,

595 East Colorado Street,

Pasadena, California,

Attorneys for Coast Metals, Inc.,

Plaintiff-Appellant.

JAN 14 1963

FRANK H. SCHMID, CLERK

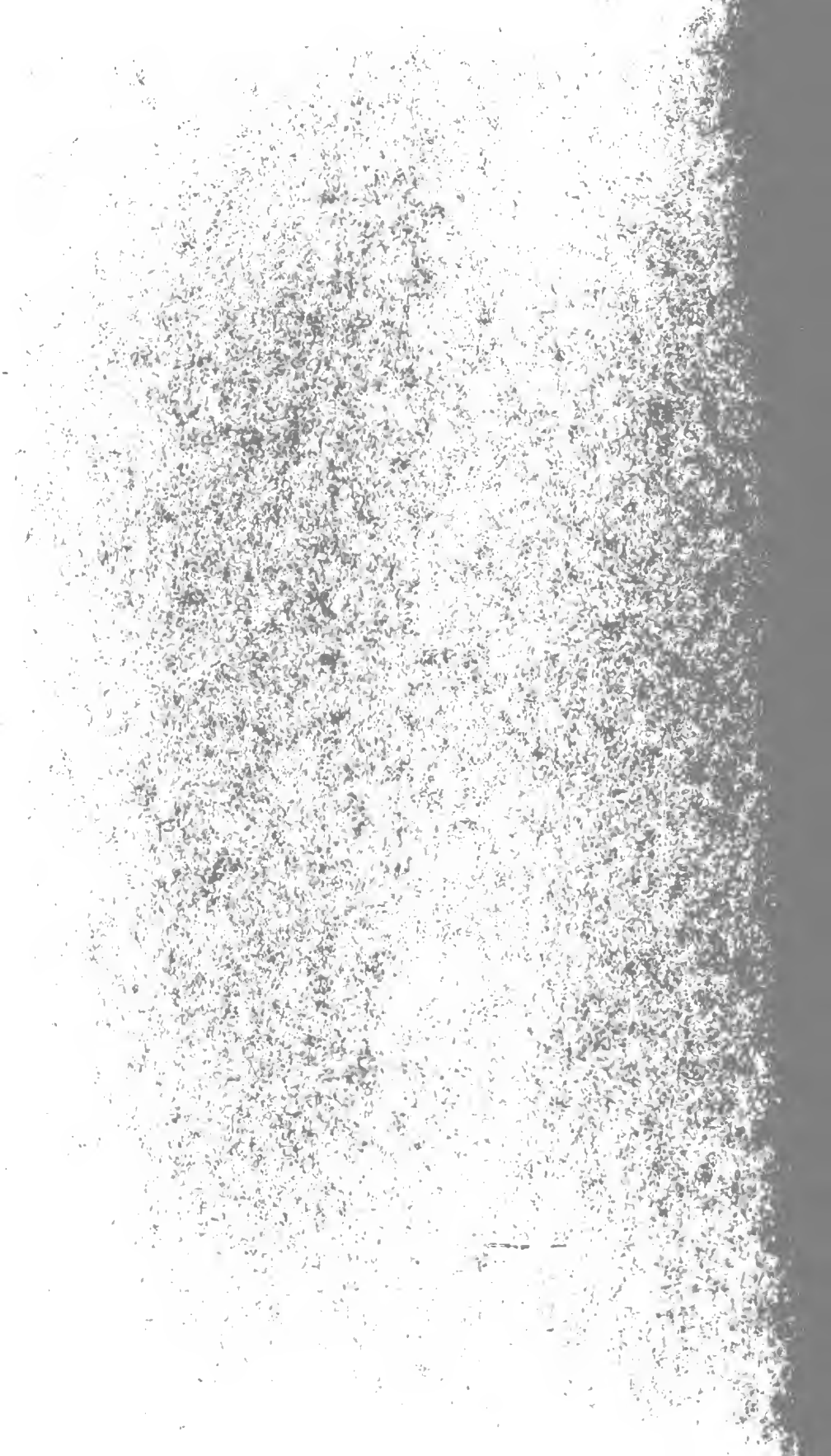

TOPICAL INDEX

| | PAGE |
|---|------|
| Wall Colmonoy fails to refer to any substantial evidence showing that the discovery of the patented alloys did not constitute invention | 2 |
| There is no basis either in fact or law for Wall Colmonoy's assertion that the patent office was misled into granting patent No. 2,743,177..... | 10 |
| There is no basis for Wall Colmonoy's assertion that claims 1, 3 and 4 of patent No. 2,743,177 are indefinite..... | 15 |
| Conclusion | 17 |

TABLE OF AUTHORITIES CITED

| CASES | PAGE |
|--|------|
| Baldwin-Lima-Hamilton Corporation v. Tatnall Measuring Systems Company, 169 Fed. Supp. 1..... | 14 |
| Carson v. American Smelting & Refining Co., 4 F. 2d 463..... | 13 |
| Cavallito, Application of, 282 F. 2d 357..... | 15 |
| Georgia-Pacific Corp. v. United States Plywood Corp., 258 F. 2d 124..... | 16 |
| Martin v. Ford Alexander Corporation, 160 Fed. Supp. 670.... | 12 |
| Pointer v. Six Wheel Corporation, 177 F. 2d 153..... | 4, 5 |
| Research Products Co. v. Tretolite Co., 106 F. 2d 530..... | 17 |
| S. D. Warren Co. v. Nashua Gummed & Coated Paper Co., 205 F. 2d 602..... | 16 |
| Toledo Rex Spray Co. v. California Spray Chemical Co., 268 Fed. 201..... | 4 |

STATUTES

| | |
|--|----|
| United States Code Annotated, Title 35, Sec. 102(a)..... | 1 |
| United States Code Annotated, Title 35, Sec. 102(b)..... | 1 |
| United States Code Annotated, Title 35, Sec. 112..... | 17 |

No. 18173

IN THE

United States Court of Appeals

FOR THE NINTH CIRCUIT

COAST METALS, INC., a corporation,

Appellant,

vs.

WALL COLMONOY CORPORATION, a corporation,

Appellee.

REPLY BRIEF FOR PLAINTIFF- APPELLANT.

The brief for defendant-appellee, Wall Colmonoy Corporation, fails to provide any support for the conclusions of the District Court that claims 1, 3, and 4 of Cape Patent No. 2,743,177, the patent in issue on appeal, are invalid by reason of prior invention and prior use, not for experimental purposes, within the meaning of 35 U. S. C. A., Sections 102(a) and 102(b). These conclusions must be taken as wholly unsupported either by the findings of fact made by the District Court or by any evidence in the record.

The gist of the contentions advanced by Wall Colmonoy in its brief appears to be that claims 1, 3, and 4 of the patent in issue are invalid by reason of want of invention. Wall Colmonoy fails to show any substantial evidence to support its contentions of want of invention, and fails almost completely to meet the

factual matters supporting validity of these claims as presented in the Opening Brief for Plaintiff-Appellant, Coast Metals, Inc.

This brief endeavors to deal as summarily as possible with those matters asserted by Wall Colmonoy relating to want of invention that are in most urgent need of correction, as well as with those new issues raised by Wall Colmonoy as to which there are neither findings of fact nor conclusions, namely, the issues of misleading the Patent Office and indefiniteness of the claims of Patent No. 2,743,177.

Wall Colmonoy Fails to Refer to Any Substantial Evidence Showing That the Discovery of the Patented Alloys Did Not Constitute Invention.

In Patent No. 2,743,177, Cape described his discovery, made prior to May 2, 1952, that nickel, silicon, and boron in the proportions specified in the patent produced alloys having a substantially enhanced combination of characteristics for brazing and hard facing. The disclosure of the patent leaves no doubt that the alloying constituents of the invention were nickel, silicon, and boron. In its brief, Wall Colmonoy does not refer to any evidence in the record to show that anyone prior to Cape had combined only nickel, boron, and silicon in the proportions specified in the claims of the patent. Even further, Wall Colmonoy does not refer to any evidence to show that anyone previous to Cape had combined nickel, boron, and silicon as the only alloying constituents of a metallic alloy. It therefore stands established that the alloy compositions claimed in claims 1, 3, and 4 were new and useful. This remains true even with due allowance for the statement in the patent to the effect that the al-

loys consisting of nickel, silicon, and boron could tolerate, whenever present in the alloy, small amounts of iron, manganese, and chromium, in a total amount of less than 5%. Certainly, the inventor could not be expected to limit his invention to a completely pure alloy, for impurities are inherent in the raw materials from which alloys are made [R. T. 73-74; 315].

Since there is no evidence to refute the fact that the patented alloys were new and useful, Wall Colmonoy in its brief attacks the validity of claims 1, 3, and 4 on the basis that the discovery of the claimed alloys did not constitute invention. Coast Metals has in its Opening Brief (pp. 42-58) set forth the evidence in the record that establishes the lack of obviousness of the alloys of claims 1, 3, and 4 considered at the time of the invention. Wall Colmonoy in its brief does not meet this evidence but argues at length the properties of its prior art Colmonoy alloys, Colmonoy Nos. 4, 5, 6, and 20, and attempts to blur the differences between these alloys and the patented alloys by interwoven references to alloys that are not a part of the prior art, namely, Coast Metals No. 53 and No. 56 and the alloys of Patent No. 2,755,183, the other patent in the suit below.

Significantly, Wall Colmonoy does not discuss the properties of its prior art Colmonoy alloys by reference to the specific compositions of these alloys. These prior art Colmonoy alloys were nickel-base alloys which contained varying amounts of boron and silicon combined with substantial quantities of chromium and iron. Of the alloys of this group, the least amount of chromium and iron was in Colmonoy No. 20 (from about 9% upward); the greatest amount of chromium and

iron was in Colmonoy No. 6 (from about 17% upward). Given that there were present in the prior art Colmonoy alloys both silicon and boron, what evidence or what finding shows that the properties or composition of the prior art Colmonoy alloys brought it within the skill of the art to strip away the large quantities of chromium and iron in the prior art Colmonoy alloys and to discover the boron-silicon relationship claimed in Patent No. 2,743,177? Wall Colmonoy points to no such evidence or finding because there is none.

Even though silicon and boron were present in some amounts in both Colmonoy No. 20 and Colmonoy No. 6, the latter had a melting point of 1925°F and chromium and iron in an amount from 17% upward, and Colmonoy No. 20 had a melting point of 2225°F and chromium and iron in an amount from 9% upward. The mere fact that these prior art Colmonoy nickel-base alloys included silicon and boron together with the large quantities of chromium and iron of itself shows nothing. As said in *Pointer v. Six Wheel Corporation*, 177 F. 2d 153, 160 (9th Cir. 1949):

“. . . invention cannot be defeated merely by showing that, in one form or another, each element was known or used before. . . .”

This statement, made with respect to the field of mechanics, is equally, if not more, applicable to the fields of chemistry and metallurgy. A chemical element in a different combination may achieve a new quality or function which is not predictable from its use in another combination. See *Toledo Rex Spray Co. v. California Spray Chemical Co.*, 268 Fed. 201, 204 (6th Cir. 1920).

In *Pointer v. Six Wheel Corporation, supra*, 177 F. 2d 153, 160, 161, the Court said:

“At times, the result is accomplished by means which seem simple afterwards. But, although the improvement be slight, there is invention, unless the means were plainly indicated by the prior art. . . .”

Wall Colmonoy points to no evidence or finding showing that the prior art Colmonoy alloys in any way indicated the silicon-boron relationship of the patented nickel-silicon-boron alloys or the properties obtained by this relationship. In the present case, the improvement obtained was more than slight. Appellant's Opening Brief has already fully set forth at pages 32-36 the evidence in the record affirmatively showing that alloys having compositions within the claims of Patent No. 2,743,177 provided significant advantages over the prior art Colmonoy alloys and it is not considered necessary to repeat it here.

In its brief (pp. 24-25), Wall Colmonoy seeks to minimize the significance of Wall Colmonoy's search for a low-melting alloy as to the issue of obviousness on the basis that the alloy LM Microbraz is “an alloy clearly outside of this patent.” namely, Patent No. 2,743,177 here in issue. It is fully agreed that LM Microbraz, which is not an alloy of the prior art as to Patent No. 2,743,177, is clearly outside the patent. Since, however, LM Microbraz contains a total amount of chromium and iron [Ex. AN at C. R. 347; 355] that is about the same as that found in the prior art Colmonoy No. 20 and is substantially less than that found in the prior art alloys Colmonoy Nos. 4, 5, 6, the

argument is singular when viewed in the light of Wall Colmonoy's efforts to bring its prior art alloys, Colmonoy Nos. 4, 5, 6, and 20 within the scope of the patent.

As to the significance of its search for a low-melting alloy, fully discussed in appellant's Opening Brief, pages 43-46, Wall Colmonoy has in its brief missed the point. The significance is that the prior art Colmonoy alloys were not low-melting alloys, as demonstrated by the fact that Wall Colmonoy, recognizing in 1952 the need for a low-melting nickel-base alloy [R. T. 341-342], sought to meet this need by the approach of isolating a low-melting alloy from its Colmonoy alloys [R. T. 342]. That this procedure resulted in an alloy, LM Nicrobraz, clearly outside the scope of the patent, forcefully demonstrates Cape's contribution to the advancement of the art and the lack of obviousness of the alloys of his invention.

In its brief, Wall Colmonoy refers to another alloy of Coast Metals, Coast Metals No. 53, covered by Patent No. 2,755,183, the single claim of which was held invalid by the District Court. While it makes comparisons between the properties and composition of Coast Metals No. 53 and the alloys covered by Patent No. 2,743,177, here in issue, Wall Colmonoy fails to point out that neither Coast Metals No. 53 nor Patent No. 2,755,183 were part of the prior art as to the patent here in issue.

The composition of Coast Metals No. 53 [Ex. DK at C. R. 434] compares to the composition of Wall Colmonoy's LM Nicrobraz [Ex. AN at C. R. 347; 355] as follows:

| | Coast Metals No. 53—% | LM Nicrobraz—% |
|----------|--------------------------|-------------------|
| Boron | 2.90 | 3.00 |
| Silicon | 4.50 | 4.50 |
| Chromium | 7.00 | 6.50 |
| Iron | 3.00 | 2.50 |
| Nickel | 82.10 | Balance |

It is fully apparent these compositions do not have the relationship of chromium to boron controlled by the chromium boride crystals which in all cases were a part of the prior art Colmonoy alloys. If this relationship were present, the amounts of chromium in Coast Metals No. 53 and LM Nicrobraz would have been between 12.5% and 13%.

LM Nicrobraz was the name given to the low-melting alloy [Find. 17, C. R. 50] first separated the prior art alloy, Colmonoy No. 6, subsequent to the filing of the application on which Patent No. 2, 743,177 issued. It was this low-melting constituent that was described by Mr. LaRou of Wall Colmonoy as having the unusual characteristic of a melting point of 1800°F [R. T. 396] which departed substantially from that of other alloys previously made and sold by Wall Colmonoy [R. T. 395]. The testimony of Wall Colmonoy's own Vice-President in charge of en-

gineering unequivocally shows that LM Nicrobraz was not a part of the same family of alloys as were the prior art alloys, Colmonoy No. 4, No. 5, No. 6, and No. 20. Equally so, Coast Metals No. 53, as is apparent from its composition in comparison with that of LM Nicrobraz, is not a part of the same family of alloys as were the prior art Colmonoy alloys.

Neither Wall Colmonoy's LM Nicrobraz nor Coast Metals No. 53 are a part of the prior art as to Patent No. 2,743,177. The testimony of Wall Colmonoy's Vice-President shows that the properties of these two alloys were significantly different and substantially departed from the properties of the prior art Colmonoy alloys, Nos. 4, 5, 6, and 20.

Equally, the alloys claimed in Patent No. 2,743,177 are separate and distinct from the group of prior art Colmonoy alloys both as to properties and composition. Whether LM Nicrobraz, Coast Metals No. 53, and the alloys described in Patent No. 2,755,183 are improvements based upon the alloys of Patent No. 2,743,177 is not material to the issue here presented since the former are not a part of the prior art as to the '177 patent.

Wall Colmonoy states in its brief, at page 6, that Patent No. 2,755,183, not here in issue, was held invalid because of the prior use and sale of Colmonoy alloys Nos. 4, 5, 6, and 20 by Wall Colmonoy. The findings do not support this unqualified erroneous assertion. While the District Court found that two of the prior art Colmonoy alloys, Colmonoy No. 4 and

Colmonoy No. 20, contained constituents in amounts within the compositional range set forth in the single claim of the '183 patent [Finds. 11 and 12, C. R. 48], it specifically found that LM Nicrobraz, an alloy not part of the prior art as to Patent No. 2,743,177, was first sold on September 16, 1952 and that this alloy was on sale more than one year prior to the effective filing date (January 25, 1955) of the application on which the '183 patent issued [Finds. 17 and 18, C. R. 50].

The record as a whole and the findings themselves are more reasonably susceptible to the conclusion that, as to the '183 patent, the prior sale referred to in the conclusion of the District Court is that of LM Nicrobraz. Wall Colmonoy's efforts to intertwine into one family all of the alloys in this record is simply not supported by the evidence.

In summary, Wall Colmonoy refers to no substantial evidence showing that the discovery of the alloys claimed in claims 1, 3, and 4 of Patent No. 2,743,177 did not constitute invention. It has not met the requirement of this Court that only clear and convincing proof which establishes lack of invention beyond a reasonable doubt can overcome the presumption of validity arising from the issuance of a patent.

There Is No Basis Either in Fact or Law for Wall Colmonoy's Assertion That the Patent Office Was Misled Into Granting Patent No. 2,743,177.

Wall Colmonoy asserts in its brief that Coast Metals' attorney made to the Patent Office false representations which induced it to issue Patent No. 2,743,177, and that resultantly the presumption of validity of the patent is destroyed. There is no finding of fact as to this assertion. There is no indication whatsoever that the District Court in any way considered such an issue in reaching its conclusions. Further, the assertion as to false representations is not supported by the evidence, and the conclusion is contrary to the law applicable to the facts in the record.

In the first instance, the evidence does not establish that the statements made in arguments by Coast Metals' attorney to the Patent Office were false. With respect to the statements to the Patent Office regarding the detrimental effect upon alloys of the presence of aluminum in amounts of 0.1% and above, Mr. Foerster, Technical Director for Coast Metals, testified as to braze samples of alloys containing substantially no aluminum [Ex. 64 at C. R. 137; Orig. Ex. 65, 66] and braze samples of alloys containing aluminum of about 0.1% and above [Ex. 64 at C. R. 137; Orig. Exs. 67, 68, 69, 70]. He testified that the samples were brazed in a tube furnace with a hydrogen atmosphere in the absence of a flux [R. T. 634]. He stated that the alloys from which the samples were prepared, Coast Metals No. 50 and No. 52, each within the claims of Patent No. 2,743,177, are used for fluxless brazing and that there are many uses of brazing alloys where

flux cannot be used [R. T. 635]. From the condition of the samples in evidence, Mr. Foerster stated that the presence of aluminum would be very detrimental where the brazing is done in furnaces without flux [R. T. 634-635].

Mr. Cape testified on cross-examination that in welding of an alloy made with an aluminum content of 0.1%, the alloy will boil and will flow very sluggishly, and that the joint will be a poor one [R. T. 66]. He stated that, while the alloy will adhere, it will not flow consistently over the surface of the base metal [R. T. 66].

In the tests as to which Mr. Miller, Wall Colmonoy's expert, testified, flux was applied and the samples were prepared in a furnace in a hydrogen atmosphere [R. T. 563]. He admitted that he did not know from direct experience whether or not an alloy containing aluminum would boil when it was applied to a surface by means of an oxy-acetylene torch [R. T. 566] and that his testimony as to lack of a detrimental effect of aluminum was only as to coating of samples by furnace fusing [R. T. 566-567]. Mr. Miller further admitted that the presence of aluminum in a brazing alloy would require for a particular base metal, such as Inconel X, a different brazing technique than would be required in the case of a brazing alloy that does not contain aluminum [R. T. 565]. He further conceded that the presence of aluminum in an alloy might require some type of remedial measure such as the applying of flux [R. T. 570].

The evidence, therefore, contrary to the assertions of Wall Colmonoy, shows that the presence of aluminum does have a detrimental effect upon the patented al-

loys. Clearly the evidence falls far short of establishing that any misrepresentation whatsoever had been made to the Patent Office.

As to the statements regarding the effect of titanium, Mr. Cape testified that the presence of titanium would be deleterious depending upon the use of the alloy [R. T. 87], as in the case of welding and brazing with torches [R. T. 88]. The fact that, since the time of the statement to the Patent Office in an amendment dated September 28, 1953, it has been found that titanium can be used for some specific jobs of brazing [R. T. 88] does not make the statement to the Patent Office untrue at the time it was made. The admission to which Wall Colmonoy refers in its brief is entirely consistent with the foregoing, for it states that a Coast Metals alloy containing titanium has special uses in conjunction with a stainless steel base metal [Ex. B at C. R. 152].

In *Martin v. Ford Alexander Corporation*, 160 Fed. Supp. 670, 685 (D. C. S. D. Cal. 1958), in denying the defense that certain statements in affidavits constituted a fraud practiced on the Patent Office, the Court said:

“. . . In a matter of this character, as in all matters relating to fraud, there must be *scienter, i.e.*, knowledge on the part of the person that what he is stating is false.

imply willfulness. Here we do not have even a showing of that type of irresponsible utterance which is, at times, identified with willfulness.”

“The frauds which call for denial of enforceability in patent law must be of the type which

In the second instance, the file wrapper of Patent No. 2,743,177 shows that the statements in the prosecution which Wall Colmonoy attacks were not “essentially material” to the issuance of the patent. In other words, entirely apart from the statements attacked by Wall Colmonoy, other grounds were presented which required that the Patent Office withdraw British Patent No. 580,686 as a basis for rejection.

In the amendment filed July 26, 1955 [Ex. E at C. R. 198-201], following which a notice of allowance issued, it was pointed out by Coast Metals’ attorney that the British Patent [Ex. F at C. R. 207] was not a proper basis for rejection of the claims in the application because [C. R. 199] “an indeterminable amount of experimentation would be necessary if applicant’s alloy was to be arrived at, and there is no assurance that even after such experimentation, the applicant would recognize the benefits derived by the present alloy.” This was an eminently correct statement of the effect to be given to a foreign patent. *Carson v. American Smelting & Refining Co.*, 4 F. 2d 463, 465 (9th Cir. 1925). The British patent made reference to boron only as one of twelve elements of a group. It was with regard to testimony as to this patent on this very point that the District Court, in overruling an objection by Wall Colmonoy’s counsel on cross-examination of defendant’s expert, said [R. T. 562]:

“The Court: I think the inquiry is correct. If one takes one of ten elements that a man says if combined with others will give you something, and says this is within the teaching of the patent, that is absurd. If a patent teaches nine ways of doing

a thing, and then somebody else selects one of those, there is no infringement, there is no anticipation.”

Since the amendment of July 26, 1955 set forth the foregoing as well as other grounds as to why the British patent did not constitute a proper basis for rejection of applicant's claims, Wall Colmonoy cannot validly assert that the patent issued because of the statements as to titanium and aluminum.

As stated in *Baldwin-Lima-Hamilton Corporation v. Tatnall Measuring Systems Company*, 169 Fed. Supp. 1, 24 (D. C. E. D. Pa. 1958):

“Furthermore, even if the statements in the November 19, 1941 amendment which have been dealt with meant to Simmons and the Patent Office what defendants say they must have meant, defendants still must prove that the statements were material in the sense that but for them the patent would not have issued. A false statement which has been recklessly made will not serve to destroy the presumption of the validity of a patent unless the statement was ‘essentially material’ to its issuance. *Corona Cord Tire Company v. Dovon Chemical Corp.*, 1928, 276 U. S. 358, 373-374, 48 S. Ct. 380, 72 L. Ed. 610. . . .”

The evidence in the record does not support Wall Colmonoy's assertion that false statements were made to the Patent Office during the prosecution of the application on which Patent No. 2,743,177 issued. Further, the law applicable to the facts here presented does not deny to that patent its presumption of validity.

**There Is No Basis for Wall Colmonoy's Assertion
That Claims 1, 3, and 4 of Patent No. 2,743,177
Are Indefinite.**

While Wall Colmonoy asserts in its brief that claims 1, 3, and 4 are indefinite and therefore invalid, it fails completely to show in what respect the claims do not particularly point out and distinctly claim the alloys of Cape's invention. Each of the three claims in issue specifically claims the alloying constituents, nickel, silicon, and boron. Each of the claims specifies defined proportions for silicon and boron and concludes "the balance of the alloy being essentially nickel." These claims fully meet the requirements of 35 U. S. C. A., Section 112.

Finding 5 [C. R. 47] simply states that the claims cover a large number of specific nickel-base hard-facing alloys in which the proportions of each of the ingredients or constituents can be varied within the compositional ranges set forth therein. Obviously, whenever a compositional range is claimed, a number of products may be produced within the range. As said in *Application of Cavallito*, 282 F. 2d 357, 361 (C. C. P. A. 1960):

"The mere fact that a claim covers a large, or even an unlimited number of products, does not necessarily establish that it is too broad. Claims are commonly allowed for alloys or mixtures which permit substantial variations in the proportions of two or more ingredients. Theoretically an indefinite number of products may be produced falling within the scope of such a claim. In the case of alloys or mixtures, however, it is generally apparent how a product of any desired proportions

may be produced, and, since the properties of the aggregate ordinarily vary in accordance with the proportions of the ingredients, the characteristics of any aggregate covered by the claim can generally be predicted with reasonable certainty if the properties of typical aggregates are known. In such cases an applicant, by fixing the ranges of proportions and describing a few examples throughout the range, may enable anyone skilled in the art to make any product covered by the claim, and may inform him as to what properties such a product will have.”

Cape specifically set forth in his patent a number of examples of the proportions of silicon and boron which together with nickel produced the substantially enhanced combination of properties found in the alloys of his invention [Ex. 1 at C. R. 72, col. 2, lines 38-54]. The claims and specification of Patent No. 2,743,177 fully meet the requirements laid down by the courts as to definiteness. In *Georgia-Pacific Corp. v. United States Plywood Corp.*, 258 F. 2d 124, 136 (2nd Cir. 1958), the Court said:

“ . . . If the claims, read in the light of the specifications, reasonably apprise those skilled in the art both of the utilization and scope of the invention, and if the language is as precise as the subject matter permits, the courts can demand no more. . . . ”

See *S. D. Warren Co. v. Nashua Gummed & Coated Paper Co.*, 205 F. 2d 602, 606 (1st Cir. 1953).

Wall Colmonoy refers to no evidence that suggests that the claims and specification of Patent No. 2,743,-

177 do not demark the invention so as to inform someone skilled in the art of the nature of the invention. It adverts only, at page 26 of its brief, to some testimony of Mr. Cape with respect to the limits of the constituents set forth in the single claim of the '183 patent, the other patent in the suit. What bearing this has on claims 1, 3, and 4 of Patent No. 2,743,177 is in no way indicated.

No issue of boundary areas to determine infringement is presented here. The infringing alloy, Nicrobraz 130, is squarely within claims 1, 3, and 4 of the patent. This Court in *Research Products Co. v. Tretolite Co.*, 106 F. 2d 530 (9th Cir. 1939), stated at page 534:

“ . . . If it is indefinite in some respects due to the comprehensive character of the invention and of the claims therefor, it is not uncertain in the area of description involved in this action. Any vagueness in these outlying boundaries of the description does not invalidate the patent as to that which is clearly defined. . . . ”

Claims 1, 3, and 4 meet the requirements of particularity of 35 U. S. C. A., Section 112, and the standards of definiteness approved by the courts.

Conclusion.

In its briefs, Coast Metals has shown that the District Court erroneously concluded that claims 1, 3, and 4 of Cape Patent No. 2,743,177 were invalid. It has demonstrated that there is not any substantial evidence showing that the discovery of the claimed alloys did not constitute invention. To the contrary, the evidence in the record showed the lack of obviousness of the

patented alloys to those skilled in the art at the time of the invention. The judgment below as to invalidity of claims 1, 3, and 4 of Cape Patent No. 2,743,177 should be reversed.

The alloy, Nicrobraz 130, sold by Wall Colmonoy should be found to infringe claims 1, 3, and 4 of Patent No. 2,743,177 as a matter of law.

Respectfully submitted,

CHRISTIE, PARKER & HALE,

By ROBERT L. PARKER,

ANDREW J. BELANSKY,

Attorneys for Coast Metals, Inc.,

Plaintiff-Appellant.

Certificate.

I certify that, in connection with the preparation of this brief, I have examined Rules 18 and 19 of the United States Court of Appeals for the Ninth Circuit, and that, in my opinion, the foregoing brief is in full compliance with those rules.

ANDREW J. BELANSKY.



No. 18173

IN THE

**United States Court of Appeals
for the Ninth Circuit**

**COAST METALS, INC., a corporation,
Plaintiff-Appellant,**

vs.

**WALL COLMONOY CORPORATION, a corporation,
Defendant-Appellee**

BRIEF FOR DEFENDANT-APPELLEE

**LYON & LYON,
CHARLES G. LYON,**

**Attorneys for Wall Colmonoy Cor-
poration, Defendant-Appellee,
811 West Seventh Street,
Los Angeles 17, California.**

Of Counsel:

**DON K. HARNESS,
NEAL A. WALDROP,
HARNESS, DICKEY & PIERCE,
7-141 General Motors Building,
Detroit 2, Michigan.**

FILED

DEC 20 1962

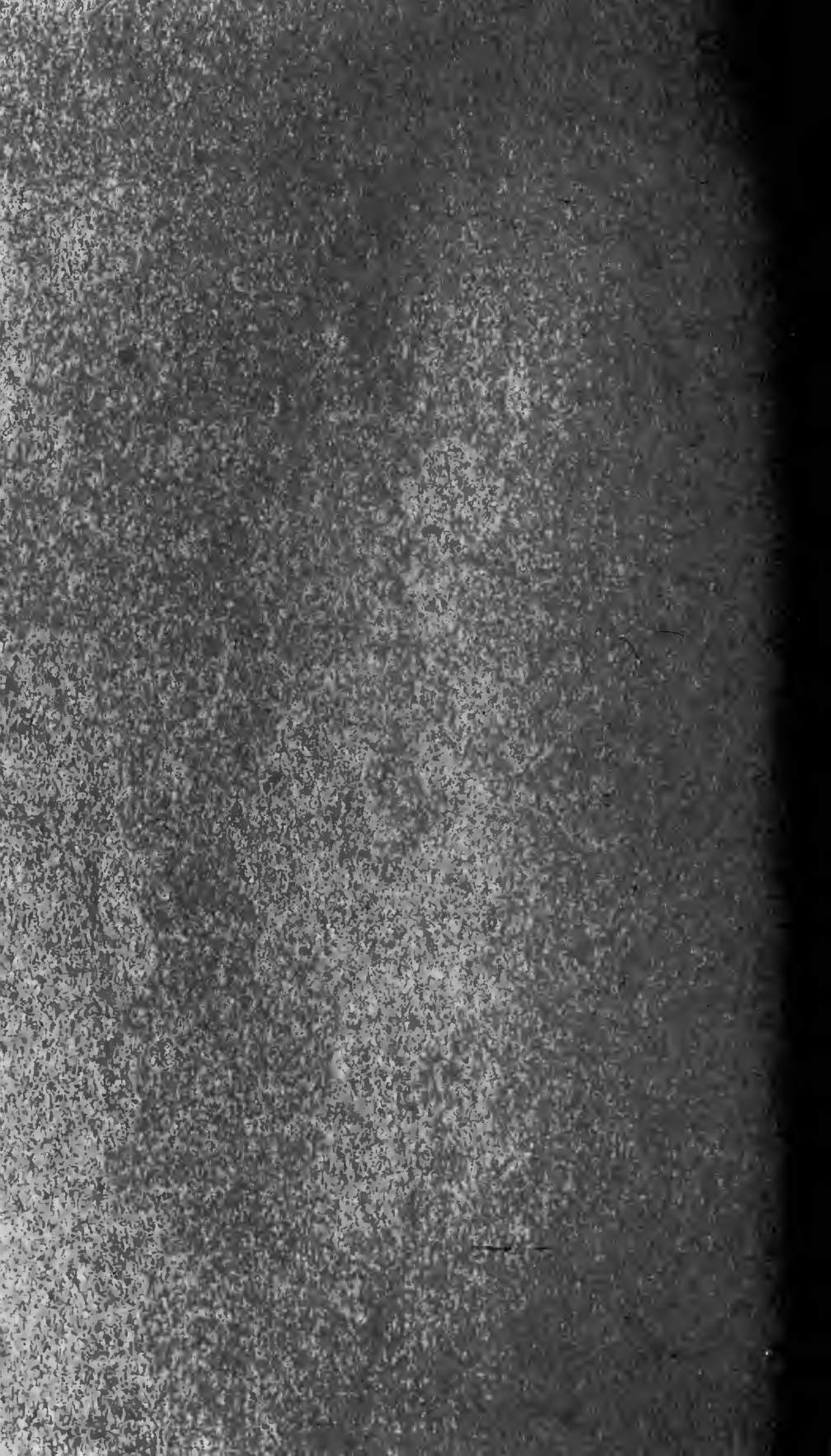

TOPICAL INDEX

| | Page |
|---|------|
| Jurisdictional statement | 1 |
| Statement of the case..... | 1 |
| A. The Issues | 1 |
| B. Wall Colmonoy Prior Art Alloys..... | 3 |
| C. The Alloys of Coast Metals and Cape '177 Patent in Suit..... | 3 |
| D. The Patent Office Was Mislead Into Issuing the '177 Patent in Suit..... | 7 |
| Summary of Argument..... | 8 |
| Argument | 10 |

I.

| | |
|--|----|
| Claims 1, 3 and 4 of the '177 Patent Cover Not Only Alloys Containing Nickel, Silicon and Boron But Also Alloys Containing Up to 5% of Chromium and Iron..... | 10 |
|--|----|

II.

| | |
|---|----|
| Claims 1, 3 and 4 of the '177 Patent Do Not Cover a Single Alloy But Cover a Wide Range of Alloys | 14 |
|---|----|

III.

| | |
|-------------------------------------|----|
| Wall Colmonoy Prior Art Alloys..... | 16 |
|-------------------------------------|----|

IV.

| | |
|---|----|
| Comparison of Properties of Alloys Disclosed and Claimed in '177 Patent With Properties of Prior Art Colmonoy Alloys..... | 19 |
|---|----|

| | Page |
|---|------|
| V. | |
| Evidence With Respect to Findings of Fact Nos. 8 and 10 and 13..... | 26 |
| VI. | |
| Claims 1, 3 and 4 of the '177 Patent Do Not Meet the Conditions for Patentability Required by the Patent Laws..... | 29 |
| VII. | |
| Comments re Appellant's Argument Relative to the Problems Overcome by the Patented Alloy and Commercial Acceptance of the Same..... | 33 |
| VIII. | |
| The Patent Office Was Misled Into Granting the '177 Patent | 35 |
| Conclusion | 39 |

TABLE OF AUTHORITIES CITED

Cases

| | |
|--|--------|
| Aller, C.C.P.A., 220 F. 2d 454..... | 31 |
| Belais, David Inc. v. Goldsmith Brothers Smelting and Refining Co., 10 F. 2d 673..... | 31 |
| Bethlehem Steel Co. v. Churchward International Steel Co., CA 3, 268 Fed. 361..... | 30 |
| Burroughs Adding Mach. v. Felt & Tarrant Mfg. Co., 243 Fed. 861..... | 32 |
| Darwin and Milner v. Kinite Corp., 72 F. 2d 437.. | 30 |
| Dow Chemical Co. v. Halliburton Oil Well Cementing Co., 324 U. S. 320; 89 L. Ed 973..... | 32, 35 |
| General Electric Company v. Wabash Appliance Corporation, 304 U. S. 364; 82 L. Ed. 1402.. | 32 |

| | Page |
|--|--------|
| Graver Tank & Manufacturing Company, Inc. v. Linde Air Products Company, 336 U. S. 271; 93 L. Ed. 672..... | 32 |
| Great Atlantic & Pacific Tea Co. v. Supermarket Equipment Corp., 340 U. S. 147, 95 L. Ed. 162 | 33 |
| Hall v. Wright, 240 F. 2d 787..... | 14 |
| Lempco Products v. Timken Axle Co., 110 F. 2d 307 | 35 |
| Minnesota Mining & Manufacturing Co. v. Coe, 99 F. 2d 986..... | 30, 31 |
| Oriental Foods, Inc. v. Chun King Sales, Inc., 244 F. 2d 909..... | 14 |
| Railroad Supply Co. v. Elyria Iron & Steel Co., 244 U. S. 285; 61 L. Ed. 1136..... | 30 |
| Schmeiser v. Thomasian, 227 F. 2d 875..... | 14 |
| Sherwin-Williams v. Margall, CA D.C. 190, F. 2d 606 | 31 |
| Stauffer v. Slenderella Systems of California, 254 F. 2d 127..... | 14 |
| United Carbon Company v. Binney & Smith Company, 317 U. S. 228; 87 L. Ed. 232..... | 32 |
| VanBrodie Milling Co. v. Cox Air Gauge System, 161 F.S. 437 (affirmed CA 9 at 279 F. 2d 313).. | 30 |
| Wayne et al. v. Humble Oil & Refining Co., 175 F. 2d 230 | 32 |

Statutes

| | |
|--------------------------------|--------|
| 35 U.S.C., Section 102(a)..... | 2, 29 |
| 35 U.S.C. Section 102(b)..... | 2, 29 |
| 35 U.S.C., Section 103..... | 29 |
| 35 U.S.C. Section 112..... | 31, 32 |

IN THE
**United States Court of Appeals
for the Ninth Circuit**

—◆—
No. 18173
—◆—

**COAST METALS, INC., a corporation,
Plaintiff-Appellant,
vs.
WALL COLMONOY CORPORATION, a corporation,
Defendant-Appellee**

—◆—
BRIEF FOR DEFENDANT-APPELLEE
—◆—

JURISDICTIONAL STATEMENT

Defendant-Appellee concurs in the jurisdictional statement appearing in Plaintiff-Appellant's Brief and does not challenge the jurisdiction of this court.

STATEMENT OF THE CASE

A. The Issues.

Plaintiff-Appellant, Coast Metals, Inc. (hereinafter referred to as "Coast Metals") brought suit against Defendant-Appellee, Wall Colmonoy Corporation, hereinafter re-

ferred to as "Wall Colmonoy") for infringement of United States patent No. 2,743,177 (hereinafter referred to as "'177 patent") and United States patent No. 2,755,183 (hereinafter referred to as "'183 patent") both of which are entitled "Nickel-Silicon-Boron Alloys" and all of the claims of which refer to "An alloy which is especially adapted for hard facing at relatively low temperatures * * *". Coast Metals charged that Wall Colmonoy's nickel base alloy designated as its "LM Microbraz" infringed the '183 patent and that its nickel base alloy designated as "Microbraz 130", which is not sold for hard facing, but only for brazing or joining parts together, infringed the '177 patent.

After full trial on the issues the District Court found both of the patents in suit invalid and not infringed by Wall Colmonoy by reason of prior invention, prior use, not for experimental purposes, by Plaintiff, Defendant and others beyond the statutory period, citing 35 USCA, Section 102(a) and Section 102(b). The District Court entered Findings of Fact, Conclusions of Law and Judgment on June 28, 1962.

Coast Metals did not appeal from the District Court's decision and judgment holding the '183 patent invalid and not infringed by Wall Colmonoy. Coast Metals has appealed from the judgment of the District Court holding claims 1, 3 and 4 of the '177 patent invalid and not infringed. The judgment of the District Court of invalidity and non-infringement with respect to the '183 patent is thus final and binding upon Appellant, Coast Metals.

The patent application which resulted in the '177 patent was filed in the United States Patent Office on May 2, 1952 and the patent application which resulted in the invalid '183 patent was filed in the United States Patent

Office on January 25, 1955. Both the '177 patent and the '183 patent relate to nickel, silicon, boron alloys which, according to the patent claims, are especially adapted for hard facing. Hard facing refers to the coating of a surface with an alloy that will provide improved resistance against wear, corrosion, oxidation and abrasion.

B. Wall Colmonoy Prior Art Alloys.

Wall Colmonoy, prior to 1951 and more than one year prior to the filing of the patent application which resulted in the '177 patent, originated and commercially sold a family of nickel base, hard facing alloys for protecting metal surfaces including alloys designated as Colmonoy No. 4, Colmonoy No. 5, Colmonoy No. 6 and Colmonoy No. 20. These alloys contained varying proportions of nickel, silicon, boron, chromium and iron and demonstrated that variations in the proportions of the elements while affecting some properties of the alloys such as melting points, hardness and the like did not produce entirely new alloys or non-analogous results (Finding of Fact No. 6 at C. R. 47). Wall Colmonoy's alloys had been extensively sold and used since the early 1940's and Coast Metals had no alloys comparable thereto until after the filing of the patent application which resulted in the '177 patent in suit.

C. The Alloys of Coast Metals and Cape '177 in Suit.

Coast Metals corporate director, A. T. Cape, assignor of the patents in suit to Coast Metals, developed for Coast Metals the alloys referred to in the patents in suit to provide Coast Metals with alloys which would compete with the alloys then being commercially sold and used by Wall Colmonoy (R. T. 88).

The alloys disclosed in the '177 patent and the '183 patent both contain nickel and like amounts of silicon and boron. The alloys of the '177 patent may contain up to 5% chromium and iron combined while the alloys disclosed in the invalid '183 patent contain 5% to 12% chromium and iron combined. The alloys coming within the scope of the '177 patent in suit contain silicon in amounts from about 2.5% to about 5.5%, boron in an amount from about 0.75% to about 5.25%, with the balance or remainder of the alloy being substantially all nickel, but as stated in the '177 patent (Exhibit 1 at C.R. 72), Column 1, lines 61-66:

“It being understood, however, that wherever the expression ‘remainder substantially all nickel’ is used in the present specification and claims, said expression is to be construed as including, whenever present in the alloy, small amounts of iron, manganese and chromium, in a total amount of less than 5%.”

The '177 patent states in Column 1, lines 15-24, that the alloys disclosed therein have certain unusual properties or uses such as the ability to adhere to stainless steel and to pure molybdenum, the ability to braze or join strips or plates of stainless steel and hard face molybdenum, the ability to be used for hard facing at relatively low temperatures where resistance to wear, impact, corrosion and oxidation are vital factors, the ability to resist oxidation at temperatures up to their melting points, the ability to be applied as facings to poppet valves with more ease than other commonly known facing metals, the ability to be bonded with a variety of base metals, the ability of being plastically formable over a wide range of temperatures as great as 150° to 350°F and the ability to be “sweated” to surfaces at temperatures below 2100°F. The '177 patent

(Column 2, lines 15-19) defines the low melting points referred to in the patent to be between 1750°F and 2100°F.

The '183 patent (Plaintiff's Exhibit 2 at C.R. 74) which has been adjudicated to be invalid, relates to a series of alloys containing the same range of silicon and boron as the '177 patent but containing more chromium and iron than the alloys referred to in the '177 patent. The '183 patent refers to the previously issued '177 patent and the alloys disclosed therein and states at lines 32-37:

“* * * I have discovered as the result of further research in connection with alloys of this type that the properties of the aforesaid alloys in certain directions can be marked improved by incorporating in the alloy chromium and iron in definite combined amounts greater than used in the alloys of said copending application.”

The “aforesaid alloys” referred to in the '183 patent are the alloys disclosed in the '177 patent and “said copending application” referred to in the '183 patent is the patent application which issued into the '177 patent in suit.

The '183 patent further states that the use of chromium and iron in the improved alloys disclosed therein is mandatory instead of optional as in the alloys covered in the '177 patent. The '183 patent further states (Column 1, lines 46-49) that the alloys referred to in the '183 patent have “in addition to the other advantageous properties obtained in the alloys of the copending application”, which resulted in the '177 patent, further advantages such as reducing the tendency of the boron and silicon of the alloys to become oxidized, more accurately maintaining the properties of the alloys and increasing the microconstituent hardness of the alloys ('183 patent, Column 1, lines 46-61).

It is, therefore, clear that the invalid '183 patent covers alloys which have all the advantages and properties of the alloys disclosed in the '177 patent as well as certain additional advantages and improved properties. The litigation, therefore, stands in the unusual position that the '183 patent, which covers improved alloys having all of the properties of the alloys disclosed in the '177 patent, has been finally adjudicated invalid because of the prior use and sale of Colmonoy alloys Nos. 4, 5, 6 and 20 by Wall Colmonoy while Coast Metals is appealing the judgment of the District Court holding invalid the '177 patent, because of the prior use and sale of Colmonoy alloys Nos. 4, 5, 6 and 20.

As is clear from reading the '177 patent and the '183 patent the claims of these patents do not cover a single alloy or a single alloy composition but as stated by the District Court's unchallenged Findings of Fact No. 5 (C.R. 47):

“The patent claims in suit do not relate to any one alloy but rather cover a large number of specific nickel base, hard facing alloys in which the proportions of each of the ingredients or constituents can be varied within the compositional ranges set forth therein.”

By varying the percentages or proportions of the ingredients in the alloys coming within the wide ranges set forth in the patent claims certain of the properties of alloys, such as melting point, hardness, etc. will change or vary slightly, as would be expected, and Coast Metals has admitted that it sells two different alloys, its No. 50 and its No. 52, both within the scope of the '177 patent, which have different melting points, different hardnesses, different resistance to wear and are used for different purposes (No. 24 at C.R. 190).

It has always been the position of Wall Colmonoy, which is supported by the Findings of Fact and Conclusions of Law of the District Court, that the alloys covered by the claims of the '177 patent and Wall Colmonoy's prior used and sold alloys so overlap and are so interrelated in their properties that the broad range of chemical compositions called for in the patent claims do not define invention and do not define new and substantially different alloys as required for patentability. The evidence in the record clearly establishes that claims 1, 3 and 4 of the '177 patent are invalid and do not define patentable invention over the prior knowledge, use and sale by Wall Colmonoy and others in the nickel base alloy field.

D. The Patent Office Was Misled Into Issuing the '177 Patent in Suit.

The evidence in the record clearly shows that the United States Patent Office Examiner would not have allowed claims 1, 3 and 4 of the '177 patent in suit in view of prior art British patent No. 580,686 (Exhibit F at C. R. 207) if he had not been misled by the attorney for Coast Metals. Coast Metals' attorney argued that the British patent required the presence of aluminum in the alloy and that the presence of any aluminum in the alloys of the '177 patent would be deleterious and destroy their ability to adhere to stainless steel and molybdenum. This evidence shows this is not true. Coast Metals' attorney made other allegations which the Patent Officer Examiner accepted as true which were not true. The misleading of the Patent Office destroyed the presumption of validity of the '177 patent because it never would have issued if the Patent Office had not been misled.

SUMMARY OF ARGUMENT

The District Court properly held claims 1, 3 and 4 invalid and not infringed by Wall Colmonoy Microbraz 130 alloy. All of its Findings of Fact are supported by the evidence in the record and based on these Findings the conclusions of law that the patent is invalid are sound under the patent laws and the courts' interpretations of these laws.

The judgment of the District Court should be affirmed because:

1. Claims 1, 3 and 4 of the '177 patent in suit cover not only alloys containing nickel, silicon and boron, but also alloys containing up to 5% chromium and iron and are, therefore, so broad in their scope as not to distinguish from other alloys sold by Coast Metals and Wall Colmonoy, including prior art alloys sold by Wall Colmonoy more than one year prior to the filing of the patent application which resulted in the issuance of the '177 patent in suit.
2. Claims 1, 3 and 4 of the '177 patent do not cover a single alloy, but cover a wide range of alloys having physical, service and use properties which vary and which overlap and are not distinguishable from other alloys outside the scope of the '177 patent including alloys sold by Coast Metals and alloys in public use and on sale by Wall Colmonoy more than one year prior to the filing of the patent application which resulted in the issuance of the '177 patent.
3. Wall Colmonoy had for many years prior to the filing of the patent application which resulted in the

'177 patent in suit sold and publicly used alloys designated as Colmonoy No. 4, No. 5, No. 6 and No. 20 which contain varying proportions of nickel, silicon, boron, chromium and iron and these alloys had varying physical, service and use properties from which the alloys covered by the '177 patent in suit either did not differ or differed only in degree so that no new, unobvious or patentable alloys are defined or distinctly claimed in claims 1, 3 and 4 of the '177 patent.

4. The alloys disclosed and claimed in the '177 patent in suit do not differ to any significant degree or extent from alloys disclosed and claimed in the Coast Metals '183 patent in suit which was held invalid by the District Court and from which judgment no appeal has been taken by Coast Metals. The alloys disclosed and claimed in the invalid '183 patent had all of the advantages and properties of the alloys covered by the '177 patent in suit and the '183 patent was finally adjudicated to be invalid because of the use and sale of the same prior art Wall Colmonoy alloys which the District Court held anticipated and invalidated claims 1, 3 and 4 of the '177 patent in suit.

5. Claims 1, 3 and 4 of the '177 patent in suit do not clearly point out and distinctly claim any invention and are indefinite and, therefore, invalid under the patent laws.

6. All of the Findings of Fact of the District Court which have been challenged by Coast Metals are supported by evidence in the record, are not erroneous and should not be disturbed or overruled by this Court.

7. Any differences which might exist between the physical service or use properties of alloys covered by the claims of the '177 patent over publicly known and

used alloys are differences in degree only and no startling or unexpected new or non-analogous results are obtained and, therefore, the claims do not define patentable invention and are invalid.

8. The Patent Office was misled into issuing the '177 patent in suit and would not have issued this patent had it not been misled by improper and untrue statements made by the Coast Metals attorney during the prosecution of the patent application which resulted in the '177 patent.

ARGUMENT

I.

CLAIMS 1, 3 AND 4 OF THE '177 PATENT COVER NOT ONLY ALLOYS CONTAINING NICKEL, SILICON AND BORON BUT ALSO ALLOYS CONTAINING UP TO 5% OF CHROMIUM AND IRON.

Appellant's specification of error No. 8 appearing at page 13 of its Brief alleges that the District Court erred in holding that claims 1, 3 and 4 of the '177 patent cover alloys containing not only nickel, silicon and boron but also alloys containing in addition up to 5% chromium and iron combined or chromium, iron and manganese combined. Appellant has argued in its Brief at pages 62-64 that Finding of Fact No. 7 made by the District Court is erroneous in this connection. Findings of Fact No. 7 C. R. 47-48) reads as follows:

“The evidence, including the specification of the '177 patent (Column 1, lines 61-66) and Plaintiff's Answers to Defendant's Interrogatories No. 10 and 11 (Defendant's Exhibit C) makes it clear that

claims 1, 3 and 4 of the '177 patent cover alloys containing not only nickel, silicon and boron but also alloys containing in addition up to 5% of chromium and iron combined or chromium, iron and manganese combined."

This Finding of Fact No. 7 is based upon clear evidence including the '177 patent itself (C.R. 72), Plaintiff's Answers to Defendant's Interrogatories No. 10 and 11 (Exhibit C at C.R. 159 and 160) and the testimony of the alleged inventor, A. T. Cape (R.T. 73 and 76-79). The '177 patent states in Column 1, lines 61-66:

"* * * it being understood, however, that whenever the expression 'remainder substantially all nickel' is used in the present specification and claims said expression is to be construed as including, whenever present in the alloy, small amounts of iron, manganese and chromium, in a total amount of less than 5%."

In the '183 patent (Exhibit 2 at C.R. 74), which has been adjudicated to be invalid and from which adjudication no appeal has been taken by Coast Metals, is stated at lines 32-37:

"I have discovered, as the result of further research in connection with alloys of this type, that the properties of the aforesaid alloys in certain directions can be markedly improved by incorporating in the alloy chromium and iron in definite combined amounts greater than used in the alloys of said copending application."

The "copending application" referred to in the aforesaid quotation from the '183 patent is the patent application which resulted in the '177 patent in suit and the "aforesaid alloys" referred to in the aforesaid quotation are the alloys referred to in the '177 patent in suit.

It is thus clear from the aforementioned quotations from the '177 patent and the '183 patent that the alloys referred to in the '177 patent in suit may contain up to 5% of chromium, iron and manganese and that the alloys of the '183 patent, which constitute an improvement over the alloys disclosed in the '177 patent, contain an even greater amount of chromium and iron than the alloys of the '177 patent. In view of these two statements above, there is no basis for Coast Metals' statements and arguments that appear at pages 3, 19, 23, 25, 29, 42, 45 and 62 of its Brief that claims 1, 3 and 4 cover alloys containing only three elements, namely, nickel, silicon and boron, and not alloys containing significant amounts of chromium and iron. Coast Metals' position is further contradicted by its Answers to Wall Colmonoy's Interrogatories No. 10 and 11 (Exhibit C at C.R. 159 and 160) wherein Coast Metals contended that alloys made by Wall Colmonoy and containing chromium and iron as well as nickel, silicon and boron infringed claims of the '177 patent in suit. During the trial Coast Metals corporate director, A. T. Cape, who assigned the patents in suit to Coast Metals testified positively that there could be up to 5% of chromium, iron and manganese in alloys covered by the '177 patent and that all alloys disclosed in the '177 patent, including those containing up to 5% chromium and iron would have substantially the same properties (R.T. 64, 65 and 73). There is no evidence in the record to the contrary.

Appellant, at pages 62 through 64 of its Brief, while arguing to the contrary, has in reality confirmed the finding of the District Court, although it argues that the '177 patent only recognizes that chromium and iron may be in the alloys as residual elements or impurities introduced into the alloy through raw materials used in their preparation. The patent makes no such statement but simply says

that there may be up to 5% of chromium, iron and manganese in the alloys covered by the specification and claims. The permissible presence of such substantial proportions of these elements certainly cannot be considered as only a tolerance in the alloys of "small amounts of impurities or residual materials" as Coast Metals now likes to call them in an effort to save its patent. It is obvious from the evidence in the record, referred to above, that claims 1, 3 and 4 of the '177 patent cover alloys which may contain not only nickel, silicon and boron as constituents but also substantial proportions of chromium, iron and /or manganese, up to 5%. Now, because it is adverse to its position Coast Metals is arguing that these patent claims cover only alloys containing three constituents, namely, nickel, silicon and boron plus some impurities that may unavoidably creep into the alloy during manufacture of the same. This is sheer argument which is contrary to the evidence in the case. Finding of Fact No. 7 (C.R. 47-48) does not say that there must be chromium, iron or manganese in the alloys covered by claims 1, 3 and 4 of the '177 patent, but simply says that the claim is broad enough to cover alloys containing up to 5% of these constituents. In view of the fact that claims 3 and 4 of the '177 patent are dependent upon claim 1 and, therefore, include all of the constituents of claim 1, they cover alloys containing up to 5% chromium, iron and manganese in the same manner as claim 1 and cannot be otherwise construed.

When the District Court found that claims 1, 3 and 4 of the '177 patent were broad enough to cover alloys containing not only nickel, silicon and boron, but also containing up to 5% of chromium, iron and manganese or chromium and iron, it had determined the scope or breadth of these patent claims and defined the alloys covered thereby. The District Court then had the right and duty

to determine whether claims 1, 3 and 4 of the '177 patent define or cover alloys that were patently new or different from alloys which had been on public use or sale more than one year prior to the filing in the United States Patent Office of the patent application which resulted in the '177 patent (35 USCA, Section 102(b)). The District Court did this and held claims 1, 3 and 4 of the '177 patent invalid on several grounds which will be hereinafter discussed. This Court has often said:

“This court has consistently held that the question of validity of a claim of a patent is one of fact. The findings of a judge upon novelty, utility and invention are entitled to great weight when made after trial of these issues. The court will respect such findings unless the record shows these to be ‘clearly erroneous.’” *Stauffer v. Slenderella Systems of California*, 254 F 2d 127, CA9.

See also *Oriental Foods, Inc. v. Chun King Sales, Inc.*, 244 F. 2d 909, CA 9; *Hall v. Wright*, 240 F. 2d 787, CA 9; *Schmeiser v. Thomasian*, 227 F. 2d 875, CA 9.

II.

CLAIMS 1, 3 AND FOUR OF THE '177 PATENT DO NOT COVER A SINGLE ALLOY BUT COVER A WIDE RANGE OF ALLOYS.

None of claims 1, 3 and 4 of the '177 patent (Exhibit 1 at C. R. 72) cover a single alloy containing definite, fixed amounts or proportions of each constituent but rather the patent claims cover a large number of specific nickel base, hard facing alloys in which the proportions of each of the ingredients or constituents can be varied within the compositional ranges set forth therein (see unchallenged Finding of Fact No. 5 at C. R. 47). For instance, claim 1

of the '177 patent states that the amount of silicon is between about 2.5% and about 5.5% and that the amount of boron is between about 0.75% and about 5.25%, and, as pointed out above, there can be up to 5% of chromium, iron and manganese, with the balance of the alloy being nickel. There are, therefore, literally hundreds of alloys which can be made within the scope of the claims of the '177 patent.

This is highlighted by Coast Metals' allegations that not only does Wall Colmonoy's Microbraz 130 alloy infringe the claims of the '177 patent, but also the other Wall Colmonoy alloys referred to in Coast Metals' Answers to Wall Colmonoy's Interrogatories Nos. 10 and 11 (Exhibit C at C.R. 159 and 160) infringe one or more of the claims of the '177 patent. The chemical compositions of these three different alloys, all alleged to infringe claims of the '177 patent are set forth below.

| | Nicrobraz 130 (Exhibit 3 at C. R. 75) | Wall Colmonoy Alloy Referred to in Int. 10 (at C. R. 159) | Wall Colmonoy Alloy Referred to in Int. 11 (at C. R. 160) |
|-----------|---|--|--|
| Silicon | 4.0%-5.0% | 2.5%-5.5% | 2.5%-5.5% |
| Boron | 3.0%-3.5% | 0.75%-5.25% | 0.75%-5.25% |
| Carbon | 0.6% max. | 0.10%-0.15% | 0.03%-0.17% |
| Cobalt | 0.3% max. | 0.3% max. | 0.3% max. |
| Chromium | .. | 0.10%-0.40% | 0.10%-0.40% |
| Iron | .. | 0.65%-0.80% | 0.30%-0.75% |
| Manganese | .. | 0.45%-0.60% | |
| Nickel | Balance | Balance | Balance |

Also, Coast Metals has admitted (Exhibit B at C.R. 147) that claim 1 of the '177 patent covers both Coast Metals' alloys No. 50 and No. 52 which, according to Plaintiff's own records and publications (Exhibit D at C.R. 171) have the following compositions:

Coast Metals No. 50 Coast Metals No. 52

| | | |
|---------|--------|--------|
| Nickel | 93.25% | 91.25% |
| Silicon | 3.50% | 4.50% |
| Boron | 1.90% | 2.90% |

These two alloys, Coast Metals No. 50 and No. 52, coming within the scope of the claims of the '177 patent, have different physical, service and use properties. For instance, according to Plaintiff's own publication (Exhibit D at C.R. 171) Coast Metals No. 50 alloy has a melting point of 1900°F-1910°F, while Coast Metals No. 52 alloy has a melting point of 1790°F-1800°F. There is thus a difference of at least 100°F in the melting points of the two alloys made by Coast Metals and covered by the '177 patent (R.T. 82 and 83). Coast Metals has furthermore admitted in its response to Wall Colmonoy's Request for Admission No. 24 (Exhibit B at C.R. 150) that Coast Metals alloys No. 50 and No. 52 are used for different purposes, have different melting points, different hardnesses and different resistance to wear.

It is, therefore, clear that claims 1, 3 and 4 of the '177 patent cover a wide range of alloys which have some different physical, service and use properties and that these patent claims do not just cover Coast Metals No. 52 alloy and Wall Colmonoy's Nicrobraz 130 alloy, as repeatedly implied in Appellant's Brief.

III.

WALL COLMONOY PRIOR ART ALLOYS.

It was well known for many years prior to the filing of the application for patent which resulted in the '177 patent that changes in the proportions of constituents of nickel base alloys would affect or change certain of the physi-

cal, service or use properties of the alloys, but that such changes would not result in a new, unobvious or patentable alloy. Wall Colmonoy had for many years, and more than one year prior to the filing of the patent application which resulted in the '177 patent, manufactured and sold a family of nickel base, hard facing alloys designated as Colmonoy No. 4, No. 5, No. 6 and No. 20 which contained various proportions of nickel, silicon, boron, chromium and iron. There is no dispute about this and in fact it is admitted by Coast Metals in its response to Request for Admissions No. 35 to 38 (Exhibit B at C.R. 153). Wall Colmonoy, at the trial, by a large amount of evidence, proved the compositions of these alloys by analyses, manufacturing specifications and publications referred to in appendices B and C attached to Appellant's Brief and by reference to Wall Colmonoy's published manual (Exhibit AE and particularly pages 4 and 5 thereof at C.R. 327 and 328). The melting temperatures of Colmonoy alloys No. 4, No. 5, No. 6 and No. 20 vary between 1900°F and 2225°F because they contain different proportions of nickel, silicon and boron, chromium and iron. It furthermore will be noted that the Rockwell hardnesses vary from 18 to 61 and that they are designed and recommended for somewhat different purposes and have different service and use properties. All of these alloys, however, as well as the alloys covered by the '177 patent in suit, are alloys in a family having the same general characteristics and properties but with individual properties differing somewhat in accordance with the somewhat different chemical compositions. Appellant, in its Brief, pages 2-11 and 36, points to the fact that the chromium and boron in Wall Colmonoy's prior art alloys come from chromium boride crystals. This is true, but has nothing to do with the issues because the patents involved in this litigation simply refer to the presence of chromium

and boron in the alloys and do not limit or cover the manner or form in which these elements are incorporated in the alloys.

Even Mr. Cape, the alleged inventor and Coast Metals' director, testified (R.T. 73 and 74) that all alloys coming within the wide range and scope of the '177 patent had substantially the same properties and that any differences which did exist would be just a matter of degree. The large amount of evidence submitted by Wall Colmonoy as to the compositions of its prior art alloys and as to their properties, as well as the testimony of several witnesses resulted in the Court's Finding of Fact No. 6 which reads as follows (C.R. 47):

“6. Prior to 1951 defendant originated, and commercially sold a family of nickel base, hard facing alloys having the properties referred to in the patents in suit including alloys designated Colmonoy No. 4, No. 5, No. 6 and No. 20. Defendant's alloys, Colmonoy No. 4, No. 5, No. 6 and No. 20 contained varying proportions of their constituents and demonstrated that such variations while affecting some properties of the alloys such as melting points, hardness and the like, did not produce entirely new alloys or nonanalogous results.”

There is no evidence to the contrary and Appellant's weak arguments about the nature of the evidence are contrary to the facts. Wall Colmonoy's vice president, L. V. LaRou, who has been with Wall Colmonoy since the 1930's testified, with voluminous supporting records and data, as to the composition and properties of these prior art Colmonoy alloys and when counsel for Coast Metals attempted to impeach this witness the District Court commented as follows about his line of attack (R. T. 364):

“* * * in the case of his own client there wasn't a scrap of paper produced, so if this is a ground for impeaching this witness his client should be impeached even more readily, because he didn't produce one scrap of paper even. To my mind the argument wouldn't even be strong. I wouldn't be very much impressed by that type of argument.”

IV.

COMPARISON OF PROPERTIES OF ALLOYS DISCLOSED AND CLAIMED IN '177 PATENT WITH PROPERTIES OF PRIOR ART COLMONOY ALLOYS.

The '177 patent in suit (C.R. 72) sets forth the objects of the invention and the advantages and properties of the alloys disclosed in the patent in Column 1, lines 15-56. In summary the '177 patent relates that the objects of the invention are to provide alloys which :

(a) have unusual adherence properties, particularly the ability to adhere to stainless steel and pure molybdenum,

(b) are useful in the brazing or joining of strips or plates of stainless steel and in the hard facing of molybdenum,

(c) are particularly well adapted for hard facing at relatively low temperatures, where resistance to wear, impact, corrosion and oxidation are vital considerations or factors,

(d) are extremely resistant to oxidation at temperatures even up to their melting points,

(e) have melting points which are so low that they may be applied as facings to poppet valves and the like with considerably more ease than is possible when

using other facing metals commercially used for this purpose (“low melting points” are defined in the '177 patent in Column 2, lines 15-16 as being between 1750°F and 2100°F.),

(f) may be readily bonded with almost any variety of base metal, satisfactory bonds being obtained at temperatures far below those required when using conventional facing metals,

(g) have the curious property of being plastically formable over a relatively wide range of temperatures, i.e. as great as 150°F to 350°F,

(h) have low coefficients of expansion and may be “sweated” at temperatures below 2100°F.

L. V. LaRou, Wall Colmonoy vice president, who has been responsible for the development and production of many of Wall Colmonoy alloys testified that all of Wall Colmonoy's prior art alloys No. 4, No. 5, No. 6 and No. 20 had these characteristics and properties (R.T. 351-356). Coast Metals' expert and the assignor of the '177 patent, A. T. Cape, generally confirmed that Wall Colmonoy's prior art alloy, Colmonoy No. 6, the only one of Wall Colmonoy's prior art alloys which he had analyzed prior to the time he started any of his work on the alloys disclosed in the '177 patent, had these characteristics (R.T. 48-58 and 72). Cape did testify (R.T. 59), without any supporting evidence, that Colmonoy No. 6 did not have as good lead oxide resistance as alloys referred to in the '177 patent and that alloys disclosed in the '177 patent had better flow and impact resistance properties than Colmonoy No. 6 (R.T. 67 and 68). Cape admitted that he had no knowledge other than general familiarity with the other Colmonoy prior art alloys No. 4, No. 5 and No. 20 although he knew

they were on sale before he started his work on these alloys (R.T. 68 and 69). As can be clearly seen from Wall Colmonoy's catalog (Exhibit AE at C.R. 327-328) the prior art Colmonoy alloy No. 4 and No. 5 also have better impact resistance than Colmonoy No. 6 which was the only prior art alloy which Mr. Cape used in the comparison to which he testified.

Insofar as flow properties are concerned again Mr. Cape made no comparison between the flow properties of the alloys described in the '177 patent and Colmonoy prior art alloys No. 4, No. 5 and No. 20. Nor is there any mention in the '177 patent of these so-called flow properties. It is, however, interesting to note that Mr. Cape testified (R. T. 35) that the presence of chromium and iron in alloys of this type increases the fluidity and wetability of the alloys. An increase in fluidity and wetability means that the alloy will flow better. Mr. Cape's aforementioned testimony was to the effect that alloys coming within the scope of the '183 patent which is invalid because of the prior use and sale of the Colmonoy alloys, have better flow properties than alloys coming within the '177 patent. In addition, Coast Metals' expert and consultant R. C. Kopituk testified (R.T. 186 and 187) that Coast Metals alloy No. 53 covered by the invalid '183 patent flowed better than the Coast Metals No. 52 alloy covered by the '177 patent in suit. Furthermore, Kopituk testified (R.T. 187 and 188) that Coast Metals No. 50 alloy, which as pointed out above, is admitted to be an alloy coming within the scope of the '177 patent in suit had about the same flow characteristics as prior art Colmonoy No. 6 alloy. In view of this testimony and evidence, it is clear that no unusual or different flow properties are obtained with all alloys coming within the scope of the '177 patent as compared with the prior art Colmonoy alloys.

With regard to Cape's unsupported testimony that alloys coming within the scope of the '177 patent had excellent lead oxide resistance he admitted (R.T. 76) he did not know whether an alloy coming within the scope of the '177 patent and containing just less than 5% chromium and iron would have good lead oxide resistance and he testified that the alloys referred to in the chart in Column 2 of the '177 patent probably contained less than 1% chromium. He also admitted that Coast Metals never sold any alloys coming within the scope of the '177 patent for use on gasoline engine poppet valves which is the most common application or use where excellent lead oxide resistance is required. He admitted that Coast Metals had sold "Eatonite", a completely different type of alloy for coating gasoline engine poppet valves, but had not sold alloys covered by the patents in suit for that purpose. In addition, Coast Metals' technical director, C. B. Foerster, testified (T.R. 513) that Coast Metals No. 52 alloy had never been sold for the purpose of coating poppet valves but that he had heard that some other alloy having a lower percentage of silicon and boron than Coast Metals No. 52 alloy had been reported to have satisfactory lead oxide resistance, but he never saw the results of any tests. Mr. L. V. LaRou, Wall Colmonoy's vice president, testified (T.R. 356 and 357) that Wall Colmonoy's Microbraz 130 alloy which is charged to infringe the '177 patent was not designed to have lead oxide resistance and that its lead oxide resistance would be far inferior to the lead oxide resistance of completely different commercial materials such as "Eatonite" which was sold by Coast Metals. There is, therefore, no credible evidence in the record that alloys covered by the '177 patent in suit have lead oxide resistance at all comparable to other commercial alloys being sold for applications such as the coating of poppet valves where such resistance is necessary.

Appellant in its Brief has continuously referred to the fact that alloys covered by claims 1, 3 and 4 of the '177 patent in suit have an unusually low melting point, far below that of the prior art Wall Colmonoy alloys (see Appellant's Brief, pages 5, 6, 18, 22, 23, 34, 44, 45, 47, 52, etc.). This argument is simply not in accordance with the evidence, and, in fact, is completely contrary thereto. For instance, the evidence clearly shows that Coast Metals own alloy No. 50, admittedly covered by the '177 patent, had a melting point of 1900°F-1910°F, which is over 100°F higher than the melting point of Coast Metals No. 52 also covered by the '177 patent. The evidence further shows (Exhibit AE at C.R. 327) that prior art Colmonoy No. 6 alloy has a melting point of 1900°F which is substantially identical to the melting point of the Coast Metals No. 50 alloy covered by the '177 patent.

In addition, Coast Metals sells an alloy designated as its No. 56 alloy, which according to Coast Metals catalog (Exhibit D at C.R. 171) and according to Coast Metals' expert and alleged inventor, A. T. Cape, is generally similar to prior art alloy Colmonoy No. 6 and has about the same amount of chromium as Colmonoy No. 6 (R.T. 55-56). It has been admitted by Coast Metals (Exhibit B at C.R. 146) that its No. 56 alloy is outside the scope of even the '183 patent which required the presence of from 5% to 12% of chromium and iron because it contains approximately 15% chromium (C.R. 171) which is about the same amount of chromium as in Colmonoy No. 6. It furthermore has been admitted by Coast Metals that its No. 56 alloy, which is outside the scope of the '177 patent and is generally similar to Colmonoy No. 6 has a lower melting point than Coast Metals No. 50 alloy covered by the '177 patent in suit (Exhibit B at C.R. 151). Thus, the evidence shows that Coast Metals own alloy containing 15% chromium and generally

similar in chemical composition to the prior art Colmonoy No. 6 alloy, has a lower melting point than alloys coming within the scope of the '177 patent and a melting point within 20°-30° of the lowest melting point which Coast Metals can point to for any of its alloys coming within the scope of the '177 patent.

Still further Coast Metals catalog (Exhibit D at C.R. 171) clearly shows that Coast Metals No. 53 alloy covered by the invalid '183 patent, has a melting point of 1790°-1800°F which is identical to that of its No. 52 alloy disclosed in the '177 patent. The lack of criticality of the melting point of these alloys is further demonstrated by the fact that A. T. Cape testified that the presence of 1% carbon in an alloy disclosed in the '177 patent could change its melting point by 50° but that this was not a significant difference which would have any effect on its properties (R.T. 63 and 64).

Still further, the '177 patent in suit (Exhibit 1 at C.R. 72) specifically defines the term "low melting point" as anywhere between 1750°F and 2100°F. Both Wall Colmonoy's prior art alloys Colmonoy No. 4 and Colmonoy No. 5 have melting points below 2100°F (Exhibit AE at C.R. 327) and therefore are low melting alloys of the type referred to in the '177 patent.

Appellant in its Brief at pages 6, 7 and 43-48 spends considerable time discussing Wall Colmonoy's search for a low melting nickel base, brazing alloy and relies on this as demonstrating the lack of obviousness of the alloys referred to in the '177 patent. What Appellant's Brief fails to state, however, is that all of the evidence and testimony referred to in the aforementioned portions of Appellant's Brief is with reference to Wall Colmonoy's alloy designated as its LM Nicrobraz which is not covered by the '177

patent but is within the scope of Coast Metals '183 patent which has been adjudicated invalid. In other words, all of the testimony of Wall Colmonoy's vice president, L. V. LaRou, (R. T. 341-342, 395-396) and the correspondence (Exhibit AP at C.R. 411) referred to at page 45 of Appellant's Brief, refer to an alloy outside the scope of the '177 patent but within the scope of Coast Metals '183 patent, now invalid. It is hard to see how Coast Metals can base or support their arguments as to lack of obviousness of the '177 patent on evidence relating to an alloy clearly outside of this patent and only within the bounds of a patent which has been finally adjudicated to be invalid.

While Appellant argues in its Brief that alloys covered by the '177 patent differ substantially from Wall Colmonoy prior art alloys such argument is refuted by the aforementioned evidence which clearly demonstrates that the '177 patent does not cover only alloys having a melting temperature of the order of 1800°F, but covers alloys having considerably higher melting temperatures and that Wall Colmonoy's prior art alloys had melting temperatures as low as alloys coming within the scope of the '177 patent. The evidence also clearly demonstrates that alloys, such as Coast Metals No. 53 and No. 56, outside the scope of the '177 patent have melting temperatures as low as the melting temperatures of any, and below those of others of the alloys coming within the scope of claims 1, 3 and 4 of the '177 patent. While one particular alloy within the wide range of the '177 patent may have a slightly different characteristic than one or more of the Wall Colmonoy prior art alloys, such as a slightly lower melting point, the same is true of alloys coming within the scope of the '177 patent, such as Coast Metals alloys No. 50 and No. 52, as pointed out above. According to the testimony of Mr. Cape, the alleged inventor (T.R. 64, 65, 73 and 74), such differences

are a matter of degree and all of the alloys covered by the patent claims 1, 3 and 4 have the same properties. Such testimony by the alleged inventor further confirms Wall Colmonoy's position that all of the alloys previously sold by it, the alloys covered by the invalid '183 patent and the alloys covered by the claims of '177 are all part of a family of alloys having the same general properties with only slight changes in degree of the properties as the proportions of constituents in the alloys are varied.

Still further the evidence shows that the proportional or percentage limitations for each ingredient recited in the patent claims are indefinite and not critical. A. T. Cape, during redirect examination, by Coast Metals' attorney testified that the expression "about 6%" for chromium which appeared in the '183 patent, usually meant 6½% or 7% and that it was not possible to precisely state what a percentage limitation is (R.T. 138). The patent claims therefore are not definite and do not distinctly point out and claim invention as required by the patent laws.

V.

EVIDENCE WITH RESPECT TO FINDINGS OF FACT NOS. 8 AND 10 AND 13.

For the reasons pointed out above it is clear that the evidence fully supports the District Court's Finding of Fact No. 10 (C.R. 48) that Wall Colmonoy's publicly used alloy No. 4, No. 5, No. 6 and No. 20 had the characteristics and service or use properties which are referred to in the patents in suit for the alloys disclosed therein. Appellant has argued in its Brief that it is not just the properties referred to in the patent which are important or relevant, but any and all properties of the alloys whether mentioned

in the patent or not. As pointed out above, alloys coming within the scope of the '177 patent have various service and use properties including various melting points, hardnesses, wear resistance, etc. and while some of the specific alloys coming within the broad range of claims 1, 3 and 4 of the '177 patent may have one particular property which differs somewhat from a comparable property in one of the Colmonoy prior art alloys the evidence clearly establishes that the Colmonoy prior art alloys had properties which so overlapped and were interwoven with the properties of the alloys disclosed in both the invalid '183 patent and the '177 patent in suit that no non-analogous or unusual properties are obtained in alloys coming within the broad range of the '177 patent. Therefore, the claims of this patent are invalid as not defining alloys which are sufficiently different in their use or service properties as to constitute invention and arise to the dignity of invention.

The District Court's Findings of Fact No. 8 and 13 (C.R. 48 and 49) found that an alloy coming within the scope of the '177 patent in suit and containing slightly less than 5% chromium and iron did not differ to any significant extent in service or use properties from an alloy coming within the scope of the invalid '183 patent (Finding No. 13) or from Wall Colmonoy's commercial alloy Colmonoy No. 20 (Finding No. 8). These Findings of Fact are based on the evidence and record discussed above as well as additional testimony, test data and evidence.

The invalid '183 patent (C.R. 74) states that the alloys disclosed therein have all of the advantages and properties of the alloys of the '177 patent, but, in addition, have improved oxidation resistance over the alloys of the '177 patent and have a higher microconstituent hardness. In order to disprove this, Wall Colmonoy, through its ex-

pert and assistant director of research, F. M. Miller, put in evidence physical specimens (Exhibit DM, DN and DO) in which surfaces have been coated with alloys coming within the scope of the '177 patent and with alloys coming within the scope of the invalid '183 patent. These specimens were made in accordance with recognized procedures and the specimens were exhibited in Court and they showed that an alloy within the scope of the '177 patent and containing practically no chromium and iron had poorer oxidation resistance than the other two alloys where oxidation resistance was substantially the same (R.T. 526). One of the latter alloys came within the scope of the '177 patent and contained slightly less than 5% chromium and iron and the other alloy contained more than 5% chromium and iron and came within the scope of the invalid '183 patent as well as the manufacturing specification (Exhibit AD at C.R. 323) for Colmonoy No. 20 alloy, as has all Colmonoy No. 20 made since 1940 (R.T. 318 and 319). In addition, Mr. Miller prepared physical specimens using the latter two alloys which were photomicrographed and subjected to a microconstituent hardness testing procedure. The photomicrographs and hardness data (Exhibits DP and DQ at C.R. 442 and 444) made by an independent laboratory were put in evidence and these showed that there was no appreciable difference in the microconstituent hardness of alloys coming within the scope of the '177 patent and the '183 patent. The District Court had the opportunity to examine all of this data and to listen to the testimony of the expert witnesses relative thereto and drew its Findings of Fact in accordance with the evidence presented.

VI.

CLAIMS 1, 3 AND 4 OF THE '177 PATENT DO NOT MEET THE CONDITIONS FOR PATENTABILITY REQUIRED BY THE PATENT LAWS.

Claims 1, 3 and 4 of the '177 patent do not meet the conditions for patentability required by the patent laws. The patent laws of the United States, 35 U.S.C., Section 102(a) and 102(b) provide:

“A person shall be entitled to a patent unless—

(a) the invention was known or used by others in this country, or patented or described in a printed publication in this or a foreign country, before the invention thereof by the applicant for patent, or

(b) the invention was patented or described in a printed publication in this or a foreign country or in public use or on sale in this country, more than one year prior to the date of the application for patent in the United States.”

In addition to the aforementioned provisions the patent laws of the United States, 35 U.S.C., Section 103 provide:

“A patent may not be obtained though the invention is not identifiably disclosed or described as set forth in section 102 of this title, if the differences between the subject matter sought to be patented and the prior art are such that the subject matter as a whole would have been obvious at the time the invention was made to a person having ordinary skill in the art to which said subject matter pertains. Patentability shall not be negated by the manner in which the invention was made.”

The law is clear that while there may be patentable novelty either in the elements of an alloy or the proportions of such elements there cannot be patentable novelty unless

the resultant alloy provides a new material or an old material with new characteristics of structure or performance embodying entirely new or at least substantially enhanced qualities of utility.

In *VanBrodie Milling Co. v. Cox Air Gauge System*, DC S.D., Cal., 161 F.S. 437, 442 (affirmed CA 9 at 279 F. 2d 313) the court said:

“So the courts have recognized, at times, invention to consist of combining certain elements in certain definite proportions, but only when an entirely new and non-analogous result is obtained.”

And quoting from *Bethlehem Steel Co. v. Churchward International Steel Co.*, CA 3, 268 F. 361, 364, the court said:

“But novelty of proportions in the sense of the patent law involves something more than figuring out proportions differing from any that were known before. It involves new results from new proportions, developing a new metal, or, it may be, an old metal with new characteristics of structure or performance, embracing entirely new, or at least substantially enhanced, qualities of utility.”

See also *Darwin and Milner v. Kinite Corp.*, CA 7, 72 F. 2d 437.

While a composition may constitute a more effective combination of familiar ingredients than those previously used, if the composition differs from the prior art only in degree or as to certain properties and no startling, unexpected or radical result is produced such composition is not patentable. See *Minnesota Mining & Manufacturing Co. v. Coe*, 99 F. 2d 986, CA D.C.; *Railroad Supply Co. v. Elyria Iron & Steel Co.*, 244 U. S. 285, 292, 61 L. Ed. 1136;

David Belais, Inc. v. Goldsmith Brothers Smelting and Refining Co., CA 2, 10 F. 2d 673, 675; *Sherwin-Williams v. Margall*, CA D.C. 190, F 2d 606, 607.

In the case of *Minnesota Mining & Manufacturing Co. v. Coe* (*supra*) the Court said at page 989:

“The use of mere skill to produce a desired improvement does not constitute invention. Nor is invention found in every slight advance which is made through the skill of those who, by reason of their employment, are aware of the constant demand of industry for new and improved appliances. The word skill, as used in this case, is equally applicable to a chemist as to a mechanic, and to a laboratory as to a workbench.”

“But a showing of great industry in experimental research is not in itself sufficient to constitute invention, when the product thereof differs from those of the prior art only in degree and the result—no matter how useful it may be—is merely one step forward in a gradual process of experimentation.”

In application of *Aller*, C.C.P.A., 220 F. 2d 454, 456 the Court said:

“More particularly, where the general conditions of a claim are disclosed in the prior art, it is not inventive to discover the optimum or workable range by routine experimentation.”

The law is also clear that where the patent claims do not particularly point out and distinctly claim subject matter regarded as invention and clearly differentiate it from what went before in the art, they foreclose future enterprise with the resources of the prior art and are invalid for failure to comply with the statute, 35 U.S.C., Section 112, which provides:

“* * * The specification shall conclude with one or more claims particularly pointing out and distinctly claiming the subject matter which the applicant regards as his invention.”

This is the law clearly established by the Supreme Court in *United Carbon Company v. Binney & Smith Company*, 317 U.S. 228, 236, 237; 87 L. Ed. 232, 237, 238 in which the court stated:

“The statutory requirement of particularity and distinctness in claims is met only when they clearly distinguish what is claimed from what went before in the art and clearly circumscribe what is foreclosed from future enterprise. * * * Whether the vagueness of the claim has its source in the language employed or in the somewhat indeterminate character of the advance claimed to have been made in the art is not material. An invention must be capable of accurate definition, and it must be accurately defined, to be patentable.”

See also *General Electric Company v. Wabash Appliance Corporation*, 304 U.S. 364, 369; 82 L. Ed. 1402, 1405, 1406; *Graver Tank & Manufacturing Company, Inc. v. Linde Air Products Company*, 336 U. S. 271, 277; 93 L. Ed. 672, 677, 678; *Wayne et al. v. Humble Oil & Refining Co.*, 175 F. 2d 230, 234 (C.A. 5); and *Burroughs Adding Mach. Co. v. Felt & Tarrant Mfg. Co.*, 243 Fed. 861, 869, 870 (C.A. 7).

In *Dow Chemical Co. v. Halliburton Oil Well Cementing Co.*, 324 U. S. 320, 90 L. Ed. 973, 975 the Supreme Court said:

“A patent claim must be based on an invention or discovery. If the invention depends upon the alleged discovery of certain limits or points, then no invention has been made, if such point or limit do not exist in fact.”

The United States Supreme Court has commented with regard to patent claims covering a combination of elements in *Great Atlantic & Pacific Tea Co. v. Supermarket Equipment Corp.*, 340 U. S. 147, 95 L. Ed. 162, 167:

“Court should scrutinize patent claims with a care proportionate to the difficulty and improbability of finding invention in an assembly of old elements.”

It is clear that the alloys defined by claims 1, 3 and 4 of the '177 patent do not distinctly claim an alloy or a plurality of alloys which are sufficiently different from the prior art alloys to arise to the dignity of invention as required by the patent laws and the court's interpretation thereof.

VII.

COMMENTS RE APPELLANT'S ARGUMENT RELATIVE TO THE PROBLEMS OVERCOME BY THE PATENTED ALLOY AND COMMERCIAL ACCEPTANCE OF THE SAME.

Appellant's Brief at pages 12 and 13 discusses how Coast Metals No. 52 alloy allegedly solved a brazing problem in rocket engine thrust chambers and to the testimony of Mr. R. C. Kopituk of Reaction Motors in this connection. Contrary to the argument made by Appellant in its Brief, Mr. Kopituk testified (R.T. 185 and 186) that Coast Metals No. 52 alloy, covered by the '177 patent was not as satisfactory for use in the rocket engine thrust chambers as Coast Metals No. 53 alloy, covered by the invalid '183 patent and outside the scope of the '177 patent. Kopituk furthermore testified that Coast Metals No. 50 alloy, also covered by the '177 patent in suit, could only be used for brazing in thrust chambers with difficulty and was comparable to

prior art alloy Colmonoy No. 6. Kopituk testified that he had no knowledge of the use of Coast Metals No. 52 alloy as a hard facing metal although he had some experience in using Coast Metals No. 53 alloy, covered by the invalid '183 patent, for hard facing. This testimony confirms the testimony of Wall Colmonoy's vice president, L. V. LaRou, that Wall Colmonoy's alloy, Nicrobraz 130, charged to infringe the '177 patent in suit, is used only as a brazing alloy and is not a hard facing alloy.

Appellant's Brief at pages 13 and 14 and 51-57 and 58 points to the fact that an Aeronautical Material Specification No. 4778 (Exhibit 6 at C.R. 78-79) was issued in 1955 which was based on Coast Metals No. 52 alloy and that Wall Colmonoy copied and imitated Coast Metals alloy No. 52. There is no evidence that Wall Colmonoy copied any alloy. Wall Colmonoy does sell an alloy coming within the range of the AMS specification, but this specification does not mention any Coast Metals alloy nor any patent. In fact AMS specification 4778 calls for an alloy having a chemical composition different from the chemical composition of Coast Metals No. 52 alloy (Exhibit 3 at C.R. 75) and a composition outside the range of claim 4 of the '177 patent which Coast Metals contends defines the optimum chemical composition for alloys coming within the scope of this patent. Appellant's Brief furthermore fails to mention that in 1960 the AMS specification 4778 was revised as AMS specification 4778-A (Exhibit 1 at C.R. 259) and that when this specification was revised the proportions of the ingredients such as silicon, nickel, boron, carbon and iron were changed, and the melting point requirements were changed (R.T. 190-193).

AMS specifications have been issued which are based on many commercially used alloys such as Wall Colmonoy's

“Standard Nicrobraz”, Coast Metals No. 50 alloy and Coast Metals No. 53 alloy, covered by the invalid '183 patent. It is to the user's advantage to have AMS specifications issued on alloys that it wants to use so that the alloys can be purchased from different suppliers under the specification numbers and the Government requires that these specifications be made of record so that the alloys can be purchased from the lowest bidder. Even if it is assumed that any of the alloys involved in this litigation have had any significant commercial success, and there is no evidence to this effect, other than that they have been used and sold, the law is clear that commercial success is not proof of invention and will not make patentable that which is not an invention. See *Lempco Products v. Timken Axle Co.*, CA 6, 110 F. 2d 307; *Dow Chemical Co. c. Halliburton Oil Well Cementing Co.*, 324 U. S. 320, 89 L. Ed. 973, 976.

VIII.

THE PATENT OFFICE WAS MISLED INTO GRANTING THE '177 PATENT.

During the prosecution in the United States Patent Office of the patent application which resulted in the '177 patent, the Patent Office Examiner continuously and finally rejected the claims of the '177 patent (Exhibit E at C.R. 181, 187, 193, 194) unless the applicant could indicate why the alloys specified in prior art British patent No. 580,686 (Exhibit F at C.R. 207) did not have the properties of the claimed alloys. In response to the rejections by the Patent Office, Coast Metals attorney stated that the British patent in all cases included aluminum in the alloy in an amount of at least 0.1% and that the presence of aluminum in an alloy of the type disclosed in the '177 patent even in as small an amount as 0.1% would produce a violent gassing

of the alloys which would destroy their ability to adhere to stainless steel and pure molybdenum, which according to Coast Metals attorney was the outstanding characteristics of these alloys (C.R. 183 and 199). Furthermore, applicant's attorney argued that the British patent permitted the presence of certain other elements, including titanium, and that the presence of titanium in the alloy of the '177 patent would be actually deleterious to the alloy (C.R. 191).

The evidence clearly establishes that both of these representations made to the Patent Office Examiner were not true. With regard to the presence of titanium Coast Metals has admitted (No. 33 Exhibit B at C.R. 152) manufacturing and selling a nickel-silicon-boron alloy of the type having generally the same percentage of nickel-silicon-boron as Coast Metals No. 52 alloy which contains titanium. In view of this admission the presence of titanium cannot be deleterious to alloys coming within the scope of the '177 patent, but actually enhances the alloy properties for certain uses.

The evidence furthermore clearly shows that the statements made to the Patent Office Examiner that the presence of aluminum in an alloy of the '177 type, would adversely affect its ability to adhere to stainless steel and molybdenum were false and constituted misrepresentations which the Patent Office Examiner accepted as true in allowing the claims in the '177 patent. This can be seen from an examination of the file history of the '177 patent (at C.R. 205) wherein the Examiner's handwritten note reads as follows: "Interview with Gardiner, July 2 '55, LeRoy okayed cls—proposed amendment along these lines. Note the Brit. ref. (examples) have aluminum whereas applicant stresses the detrimental features of aluminum."

In order to demonstrate to the District Court that the presence of small amounts of aluminum in alloys of the type referred to in the '177 patent would not deleteriously

affect the ability of the alloy to adhere to stainless steel and molybdenum, Wall Colmonoy's assistant director of research, F. M. Miller, had an alloy prepared like the accused alloy Nicrobraz 130 to which was added an aluminum content of over 0.1% (Exhibit DW at C.R. 449) and Mr. Miller supervised brazing and coating tests of this aluminum-containing alloy on stainless steel and molybdenum and made comparisons of the coated and brazed specimens with specimens coated and brazed with an identical alloy which did not contain aluminum (T.R. 543-545). Mr. Miller explained in detail how these tests were conducted and showed the District Court the actual specimens (Exhibit DX) which were brazed and coated with the aluminum containing alloy and the non-aluminum containing alloy. These specimens along with Mr. Miller's testimony clearly showed that the aluminum containing alloy satisfactorily coated the molybdenum and satisfactorily brazed stainless steel parts together and that the joint obtained in the brazed parts was strong, as indicated by a twisting test applied to the brazed specimens (T.R. 546-549). Coast Metals' technical director, C. V. Foerster, also testified regarding some tests he had run on alloys covered by the '177 patent to which even larger amounts of aluminum had been added and that such alloys did adhere to stainless steel and were as satisfactory as non-aluminum containing alloys covered by the '177 patent except for their color or appearance (R.T. 645). These tests, therefore, clearly demonstrated to the District Court that an alloy of the type covered by the '177 patent with .1% aluminum was satisfactory for brazing and coating stainless steel and molybdenum and that the Patent Office Examiner was misled into allowing claims 1, 3 and 4 of the '177 patent. The misleading of the Patent Office Examiner destroys the normal presumption of validity to which a patent is usually entitled.

It furthermore is clear that while the alloy examples set forth in the complete specification of the British patent No. 580,686 (Exhibit F at C.R. 207 and 208) all disclose the presence of aluminum, the provisional specification which appears on the first page of the patent does not require the presence of aluminum in the alloys disclosed. The provisional specification of the British patent discloses an alloy containing silicon in a proportion which may be in the range of the '177 patent, several materials, one of which may be boron, in a proportion within the range of the '177 patent, and the balance being nickel. This is clearly demonstrated by the bar graph (Exhibit DT at C.R. 447) which compares the composition of the alloys described in the British patent No. 580,686 with all of the claims of the '177 patent in suit. The evidence presented to the District Court, therefore, clearly shows that the United States Patent Office would not have allowed the '177 patent over British prior art patent No. 580,686 if the Examiner had not been misled, and for the reasons set forth above, the British patent constitutes a sound prior art reference which invalidates the claims 1, 3 and 4 of the '177 patent.

CONCLUSION

The evidence in the record clearly supports all of the Findings of Fact of the District Court and supports the judgment below that claims 1, 3 and 4 of the '177 patent are invalid and not infringed by Wall Colmonoy.

The judgment of the District Court should be affirmed.

Respectfully submitted,

LYON & LYON,

Attorneys for Wall Colmonoy Corporation, Defendant-Appellee,

By CHARLES G. LYON.

Of Counsel:

HARNESS, DICKEY & PIERCE,

By DON K. HARNESS

NEAL A. WALDROP

CERTIFICATE

I certify that, in connection with the preparation of this Brief, I have examined Rules 18 and 19 of the United States Court of Appeals for the Ninth Circuit, and that in my opinion, the foregoing Brief is in full compliance with those rules.

Don K. Harness

PROOF OF SERVICE

Don K. Harness, counsel for Appellee, Wall Colmonoy Corporation, in the above entitled matter hereby certifies that three (3) copies of the foregoing Brief were placed in the United States mail, air mail, special delivery, with postage fully prepaid, addressed to Christie, Parker & Hale, 595 East Colorado Street, Pasadena 1, California, on this 18th day of December, 1962.

Don K. Harness



No. 18174 ✓

IN THE

State Court of Appeals
FOR THE NINTH CIRCUIT

*The First National City Bank of Los Angeles, as
Successor to the Will of Benjamin Harrison Sheldon,
Deceased, and Honey House,*

Appellants and Cross-Appellees

vs.

*Walter W. Moore, as Administrator of the Estate of Walter
H. Sheldon, Deceased,*

Appellee and Cross-Appellant.

**OPENED BRIEF OF APPELLANT
MAE SHELTON.**

FILED

THOMAS H. HEDGECOCK

614 Wilshire Boulevard,
Los Angeles 5, California.

Attorney for Appellants Mae Sheldon.



TOPICAL INDEX

| | PAGE |
|---|------|
| Statement showing jurisdiction..... | 1 |
| Statement of case..... | 2 |
| Specification of errors..... | 7 |
| Argument | 10 |
| A. In determining the amount of the judgment for conversion the trial court failed to follow the mandate of the United States Court of Appeals and failed to balance the equities | 10 |
| 1. Preliminary statement | 10 |
| 2. The trial court again erred in failing to credit against the judgment for conversion the reasonable value of the services rendered by Ben Sheldon..... | 12 |
| a. The trial court erred in its interpretation of the partnership agreement..... | 12 |
| b. The trial court erred in disallowing as a credit against the judgment for conversion the \$57,-200.00 advanced by Sheldon to the trailer business | 15 |
| c. Summary | 16 |
| B. The judgment against Mae Sheldon in the sum of \$55,000.00 is not sustained by the findings of fact or the evidence | 17 |
| 1. Introductory | 17 |
| 2. The judgment in the sum of \$55,000 is not sustained by the findings of fact relating to alleged secret profits and unjust enrichment..... | 20 |
| (a) The profit on the GSA contract (\$11,161.33).. | 22 |
| (b) Expense allowance \$14,814.00..... | 24 |
| (c) Salaries recorded \$80,352.42..... | 25 |
| (d) Shifting of \$78,571.88 oil losses..... | 27 |

| | PAGE |
|---|------|
| 3. The judgment for \$55,000 is not sustained by the findings of fact relating to the capitalization of profits | 31 |
| 4. Supplemental finding of fact No. 14 is not sustained by the evidence or supported by the pleadings | 32 |
| (a) There is no pleading to support a recovery of the accounting fees, or any portion thereof..... | 33 |
| (b) The accounting fees of Mr. Villee do not constitute a proper item of special damage..... | 34 |
| (c) The record amply demonstrates that the accounting fees of Mr. Villee were expended for the purpose of preparing testimony to be given at the trial, and for purposes entirely unrelated to the provisions of the second paragraph of Section 3336 of the California Civil Code..... | 36 |
| Summary | 38 |
| 1. As to judgment for conversion..... | 38 |
| 2. As to the additional judgment against Mae Sheldon.... | 40 |

INDEX TO APPENDICES

| | |
|-------------------|----|
| Appendix 1 | 1 |
| Appendix 2 | 2 |
| Appendix 3 | 4 |
| Appendix 4 | 9 |
| Appendix 5 | 10 |
| Appendix 6 | 12 |
| Appendix 7 | 13 |
| Appendix 8 | 17 |
| Appendix 9 | 24 |
| Appendix 10 | 27 |

TABLE OF AUTHORITIES CITED

| CASES | PAGE |
|--|--------|
| Alexander v. Nash-Kelvinator Corporation, 261 F. 2d 187, 271 F. 2d 524..... | 39 |
| Jones v. Jones, 254 Ky. 475, 71 S. W. 2d 999..... | 15 |
| Kalez v. Miller, 20 Wash. 2d 362, 147 P. 2d 506..... | 14 |
| Koehler v. Hunter, 166 Ark. 27, 265 S. W. 972..... | 14 |
| Sears v. Munson, 23 Iowa 380..... | 15 |
| Sherman v. Finch, 71 Cal. 68..... | 37 |
| Strattan v. Tabb, 8 Ill. App. 225..... | 15 |
| Ward v. Taggart, 51 Cal. 2d 736..... | 30 |
| STATUTES | |
| Civil Code, Sec. 3336 | 35, 37 |
| United States Code, Title 28, Sec. 1332..... | 1 |
| TEXTBOOK | |
| 53 American Jurisprudence, p. 896..... | 33 |

No. 18174

IN THE

United States Court of Appeals
FOR THE NINTH CIRCUIT

SECURITY-FIRST NATIONAL BANK OF LOS ANGELES, as
Executor of the Will of Benjamin Harrison Sheldon;
MAE SHELDON; and ROBERT HOHLY,

Appellants and Cross-Appellees,

vs.

EVA S. LUTZ, as Administratrix of the Estate of Walter
A. Lutz, Deceased,

Appellees and Cross-Appellants.

**OPENING BRIEF OF APPELLANT
MAE SHELDON.**

Statement Showing Jurisdiction.

This is the second appeal in the above-entitled matter. The opinion of the United States Circuit Court of Appeals upon the first appeal was reported in 297 F. 2d 160. Jurisdiction is founded upon diversity of citizenship. The decedent, Walter A. Lutz, was a citizen of the State of Washington, and defendants are citizens of the State of California. The amount in controversy exceeds the sum of \$10,000.00 exclusive of interest and costs. (28 U. S. C. Sec. 1332.)

The facts involved in the instant case are correctly summarized and stated in the first opinion. (297 F. 2d 160.)

During the pendency of this matter the plaintiff, Walter A. Lutz, died and his wife, Eva S. Lutz, as Administratrix of the Estate of Walter A. Lutz, Deceased, has been substituted as the plaintiff herein.

Statement of Case.

In order to avoid needless repetition, Appellant Mae Sheldon joins in and adopts the Statement Showing Jurisdiction and Summarizing Prior Proceedings and Summary Statement of the Case as set forth in the Opening Brief of Security-First National Bank of Los Angeles, as Executor of the Will of Benjamin Harrison Sheldon. In addition to the foregoing adoption by reference, this Appellant will, at the risk of some repetition, review the facts and proceedings having a direct and pertinent bearing upon the personal judgment rendered against Appellant Mae Sheldon.

Following the trial in 1959 before the court without a jury, the court gave notice of the manner in which it proposed to enter judgment, and directed that proposed Findings of Fact, Conclusions of Law and Judgment be prepared in accordance therewith by Lutz. With respect to the liability of Mae Sheldon the order read:

“That it appearing to the Court that plaintiff has not sustained the burden of establishing, by a preponderance of the evidence, the claims of actual fraud asserted by plaintiff, but that plaintiff has fully established, by a clear preponderance of the evidence, the claims of conversion and constructive fraud and negligence asserted by plaintiff, accordingly findings of fact, conclusions of law and judgment for damages and interest and costs are ordered in favor of plaintiff as follows:

(a) Against all defendants, other than defendant Robert Hohly, for conversion;

(b) Against defendants May Sheldon and Robert Hohly for constructive fraud; and

(c) Against defendant Robert Hohly for negligence.

(6) That the amount of the judgment so awarded plaintiff as against each of the defendants shall be for the sum of damages and interest claimed for conversion in plaintiff's closing memorandum filed August 4, 1959, plus plaintiff's costs.

(7) That plaintiff's attorneys will serve and lodge with the Clerk, within ten days, findings of fact, conclusions of law and judgment as herein ordered, to be settled pursuant to Local Rule 7.

November 6, 1959.

/s/ WM. C. MATHES,
United States District Judge."

[Tr. pp. 179-180.]

The memorandum filed by plaintiff's attorneys pursuant to Local Rule 7 claimed the total value of the shares of stock and debentures converted to be \$25,217.-07 and requested judgment for interest thereon at the rate of 7% per annum from the date of conversion, to wit, May 8, 1956, to December 7, 1959, in the amount of \$5,442.68, resulting in a total judgment of \$31,566.25. Thereafter, Findings of Fact, Conclusions of Law and Judgment were signed and filed herein. Judgment was rendered in favor of the plaintiff against all of the defendants in the sum of \$31,566.25. [Tr. pp. 225-226.]

Thereafter and pursuant to motions filed by the parties to amend or modify the Findings of Fact, Con-

clusions of Law and Judgment, the trial court made an order reading in part as follows:

“That plaintiff’s motion, filed December 21, 1959, to amend and supplement the findings of fact entered December 10, 1959, is hereby granted to the extent that finding of fact numbered 41 now appearing at lines 2-4 on page 20 of the findings of fact, conclusions of law and judgment is hereby amended to read as follows:

‘Plaintiff has been damaged in the sum of \$30,-447.38 to June 8, 1959, with interest at the rate of \$4.90 per day thereafter until the entry of judgment, for the conversion of the stock identified in finding 37 above, and in the additional sum of \$15,000 for his detriment suffered and the benefits and advantages obtained by defendant Mae Sheldon as a result of her constructive fraud.’” [Tr. p. 237.]

and made a new judgment as follows:

“It is Hereby Ordered, Adjudged and Decreed:

That the plaintiff, Walter A. Lutz, do have and recover judgment against defendants Mae Sheldon, Robert Hohly, James G. Thompson and Flamingo Trailer Manufacturing Corporation, a corporation, and against defendant Security-First National Bank of Los Angeles, as Executor of the Will of Ben H. Sheldon, Deceased, payable by said bank in the due course of administration of said estate, for the sum of \$31,566.45; and against defendant Mae Sheldon for the additional sum of \$15,000 compensatory damages; and against defendant Robert Hohly for the additional sum of \$15,000 exemplary damages; and for plaintiff’s costs of suit herein incurred, as taxed.” [Tr. p. 238.]

By this judgment the personal liability of Mae Sheldon was increased in the additional sum of \$15,000.

With respect to this additional judgment, the United States Court of Appeals in its opinion (297 F. 2d 165) stated:

“Judgment against Mae Sheldon in the additional sum of \$15,000.00 must be set aside and this matter remanded for further findings with reference to the reasonable value of services rendered and expenses properly incurred.”

After proceedings on remand, the trial court made its Supplemental Findings of Fact and Amended Conclusions of Law and Judgment Following Remand, which judgment, with respect to the personal liability of Mae Sheldon, reads in part as follows:

“REVISED JUDGMENT

In accordance with the foregoing Findings of Fact and Conclusions of Law, IT IS HEREBY ORDERED, ADJUDGED AND DECREED THAT:

The plaintiff, Walter A. Lutz, do have and recover judgment against the defendants as follows:

(1) As against the Security First National Bank, as Executor of the Will of Ben H. Sheldon, Deceased, for conversion, in the sum of \$31,566.25, together with interest thereon at seven per cent (7%) per annum from December 10, 1959, to the date of payment, to be paid in the due course of administration of such Estate;

(2) As against Mae Sheldon, for conversion and constructive fraud, in the sum of \$55,000, less any *principal* sum actually received by plaintiff pur-

suant to (1) of this judgment, by way of mitigation;

(3) As against Robert Hohly, for constructive fraud and negligence, in the sum of \$55,000, less any *principal* sum actually received by plaintiff pursuant to (1) of this judgment, by way of mitigation;

(4) As against all of such defendants, for plaintiff's costs of suit incurred in this Court, and taxed in the sum of \$.....

April 26, 1962.

/s/ WM. C. MATHES,
United States District Judge"

[Supplemental Transcript of Record after Remand,
p. 609.]

By the foregoing judgment, the additional liability of Mae Sheldon, which had been fixed at \$15,000 in the second judgment entered by the court, was further increased. The record [Tr. p. 181] indicates that the principal amount of the judgment for conversion was \$25,217.07 and if this be the sum referred to by the trial court when it uses the language in the above judgment "less any principal sum actually received by plaintiff pursuant to (1) of this Judgment by way of mitigation", then the additional judgment against Mae Sheldon has been increased from \$15,000 to \$29,782.93 (\$55,000.00 less \$25,217.07).

In summary, the foregoing shows that the trial court has now rendered three separate judgments, each punishing Mae Sheldon by increasing the amount of the personal judgment rendered against her, while the judgment for conversion has remained constant.

From the standpoint of Mae Sheldon, the questions involved are:

1. Contrary to the mandate of the United States Court of Appeals, the trial court, after remand, again failed to give consideration to or make allowances for the advances of \$57,200.00 made by Ben Sheldon to the partnership.

2. The determination of the trial court of the reasonable value of the services of Ben Sheldon to the partnership and to the corporation is not sustained by the evidence.

3. The determination of the trial court that the Sheltons wrongfully obtained in excess of \$170,000 from the corporation and partnership is not sustained by the evidence.

4. The inclusion by the trial court of projected profits of the trailer business in fixing damages is erroneous.

Specification of Errors.

The trial court erred in the following particulars:

1. The finding of the trial court with respect to the reasonable value of the services rendered by Ben Sheldon to the partnership and corporation is not sustained by the evidence.

2. The supplemental finding of the trial court that the defendants have never attempted to substantiate or prove the propriety of the expenses paid by Ben Sheldon by the corporation is not sustained by the evidence.

3. The construction placed by the trial court upon Paragraph 23 of the Partnership Agreement as set forth in Paragraph 2 of the Supplemental Findings of Fact [Supplemental Transcript of Record after Remand, p.

601, lines 15-22] is not supported by the evidence and is contrary to the law of the case established on the first appeal.

4. The additional finding set forth in Paragraph 3 of the Supplemental Findings of Fact [Supplemental Transcript of Record after Remand, p. 601, line 23, to p. 602, line 2] is not sustained by the evidence and is contrary to the law of the case established on the first appeal.

5. The additional finding of fact set forth in Paragraph 4 of the Supplemental Findings of Fact [Supplemental Transcript of Record after Remand, p. 602, lines 3-5] is not sustained by the evidence and is contrary to the law of the case established on the first appeal.

6. The additional finding of fact set forth in Paragraph 5 of the Supplemental Findings of Fact [Supplemental Transcript of Record after Remand, p. 602, lines 6-16] is not sustained by the evidence.

7. The additional finding of fact set forth in Paragraph 6 of the Supplemental Findings of Fact [Supplemental Transcript of Record after Remand, p. 602, lines 17, to p. 603, line 5] is not sustained by the evidence.

8. The additional finding of fact set forth in Paragraph 7 of the Supplemental Findings of Fact [Supplemental Transcript of Record after Remand, p. 603, lines 6-21], is not sustained by the evidence.

9. The additional finding of fact set forth in Paragraph 8 of the Supplemental Findings of Fact [Supplemental Transcript of Record after Remand, p. 603, lines 22-29] is not sustained by the evidence.

10. The additional finding of fact set forth in Paragraph 9 of the Supplemental Findings of Fact [Supplemental Transcript of Record after Remand, p. 603, line 30, to p. 604, line 6] is not sustained by the evidence.

11. The additional finding of fact set forth in Paragraph 10 of the Supplemental Findings of Fact [Supplemental Transcript of Record after Remand, p. 604, lines 7-15] is not sustained by the evidence, and is contrary to the law of the case established on the first appeal.

12. The additional finding of fact set forth in Paragraph 11 of the Supplemental Findings of Fact [Supplemental Transcript of Record after Remand, p. 604, lines 16-28] is not sustained by the evidence, and is contrary to the law of the case established on the first appeal.

13. The additional finding of fact set forth in Paragraph 12 of the Supplemental Findings of Fact [Supplemental Transcript of Record after Remand, p. 604, line 29, to p. 606, line 1] is not sustained by the evidence and is contrary to the law of the case established on the first appeal.

14. The additional finding of fact set forth in Paragraph 14 of the Supplemental Findings of Fact [Supplemental Transcript of Record after Remand, p. 606, lines 2-6] is not sustained by the evidence.

15. The additional finding of fact set forth in Paragraph 15 of the Supplemental Findings of Fact [Supplemental Transcript of Record after Remand, p. 606, lines 7-13] is not sustained by the evidence.

ARGUMENT.

A. In Determining the Amount of the Judgment for Conversion the Trial Court Failed to Follow the Mandate of the United States Court of Appeals and Failed to Balance the Equities.

1. Preliminary Statement.

After the decision upon the first appeal, the parties convened before the trial court on February 19, 1962, for such further proceedings in the trial court as were necessary to carry out the instructions of the United States Court of Appeals as set forth in its opinion.

The Reporter's Transcript of the proceedings on February 19, 1962, amply demonstrates that the trial court failed to understand the plain language in the opinion of the United States Court of Appeals. At least the record shows that the trial court professed to find much that was uncertain in the opinion of the court of appeals. The trial court's uncertainty and confusion might well have been occasioned by the fact that the trial court had not read the briefs which had been filed with the United States Court of Appeals. [See p. 79, Rep. Tr. Feb. 19, 1962, lines 3-5]. It therefore could not know the grounds of the appeal, the specifications of errors set forth in the briefs, and the arguments thereon, to which the opinion of the court of appeals was responsive. Indeed, this same confusion and uncertainty has been carried over into the judgment from which this appeal has been taken, as the trial court makes the Supplemental Finding of Fact in paragraphs 1(a), 1(b) and 1(c) [Supplemental Transcript of Record after Remand, page 600] on one interpretation of the mandate of the court of appeals, and

then makes Supplemental Findings of Fact 2 to 16, inclusive, on another and allegedly different interpretation of the mandate of the court of appeals. The revised judgment then rendered is totally at variance with the Supplemental Findings of Fact in paragraphs 1(a), 1(b) and 1(c).

Thus, the confusion already inherent in plaintiff's amended complaint, the pre-trial conference order (of which the trial court justly complains) is compounded by the Supplemental Findings of Fact and the revised judgment from which this appeal is taken.

We find this elementary statement of law in American Jurisprudence:

“After a case has been determined by the reviewing court and remanded to the trial court, the duty of the latter is to comply with the mandate of the former. The mandate of the reviewing court is binding on the lower court and must be strictly followed and carried into effect according to its true intent and meaning, as determined by the directions given by such reviewing court. Public interest requires that litigation shall come to an end speedily, so that when a cause has been tried to judgment, and the merits of the trial determined upon appeal, the trial court, upon remittitur, has no power but to obey the judgment of the appellate court.” (3 Am. Jur. pp. 730-731.)

We trust that this litigation may finally be disposed of on this appeal notwithstanding the confusion which exists in the record.

2. **The Trial Court Again Erred in Failing to Credit Against the Judgment for Conversion the Reasonable Value of the Services Rendered by Ben Sheldon.**

Upon the first appeal in this matter the opinion of the United States Court of Appeals stated that as to the amount of the judgment for conversion the appellants were entitled to credits in the sum of \$57,200 advanced by Sheldon to the partnership and the reasonable value of the services rendered by Sheldon to the partnership.

Contrary to this opinion the trial court on proceedings after remand again rendered judgment for conversion in exactly the same amount as it had rendered upon the judgment from which the first appeal was taken.

This particular matter is argued at length in the opening briefs of Robert Hohly and of the Security-First National Bank of Los Angeles, as Executor of the Will of Benjamin H. Sheldon, Deceased. Appellant Mae Sheldon joins in and adopts as a part of this brief the arguments and points and authorities set forth and contained in the opening briefs of Robert Hohly and of said bank, and will hereinafter in this brief attempt to supplement their argument and avoid needless repetition.

a. *The Trial Court Erred in Its Interpretation of the Partnership Agreement.*

Without any evidence whatsoever having been taken by the court during the proceedings after remand, the trial court nevertheless made a finding construing paragraph 23 of the partnership agreement and found
“that the partners intended that B. H. Sheldon should not be paid any salary unless and until a

definite agreement had been made to that effect. B. H. Sheldon never asked for such agreement and no agreement was ever made." [Supplemental Transcript of Record after Remand, p. 601.]

Again, without any evidence whatsoever having been introduced during the proceedings after remand, the trial court found that "Sheldon disclaimed and waived any right to salary, July 1, 1954 to March 3, 1956." [Supplemental Transcript of Record after Remand, p. 602.]

Such findings were made notwithstanding the plain language of the opinion of the United States Court of Appeals which specifically held that under the partnership agreement Sheldon was entitled to receive the reasonable value of his services.

With respect to the additional judgment against Mae Sheldon, the provision for remand in the opinion of the United States Court of Appeals was definite and unambiguous. "Judgment against Mae Sheldon in the additional sum of \$15,000.00 must set aside and this matter remanded for further findings with reference to the reasonable value of services rendered and expenses properly incurred." (297 F. 2d 165.)

While we do not think we are again compelled to argue this point, we nevertheless will again point out that Paragraph 23 of the Partnership Agreement [Tr. pp. 65-66] specifically provided that "the General Partners shall be paid such reasonable compensation for services in the operation of the business * * *."

Ben Sheldon died March 3, 1956. From July 1, 1954, to the date of his death he rendered valuable services to the partnership and to the corporation.

Subsequent to his death, Walter A. Lutz filed this action and for relief appealed to the court as a court of equity. The time-honored maxim "He who seeks equity must do equity" is clearly applicable to the circumstances of this case. The construction of the trial court of Paragraph 23 does violence to this maxim. Furthermore, it is contrary to elementary principles of law.

Where a partnership agreement clearly contemplates the payment of salary to one or more partners but no amounts are specified, the courts have held that the contracting partners intended the payment of "reasonable" salaries. Thus in *Koehler v. Hunter*, 166 Ark. 27, 265 S. W. 972, where a written partnership agreement provided that a partner should have full management and control of the business and that he should draw a salary after the actual operation of the plant had begun, and the agreement did not specify the amount of the salary, the court held that such managing partner should have been allowed a reasonable salary for his services after the plant had commenced to operate and remanded the case for further proceedings in order to allow either party to introduce evidence as to the reasonable value of the services rendered.

In *Kalez v. Miller*, 20 Wash. 2d 362, 147 P. 2d 506, the trial court in decreeing the dissolution and adjusting accounts of an association of doctors, which purported to be a corporation but which was treated as a partnership because the purpose of the corporation was not a legitimate corporate enterprise, gave effect to employment contracts between the doctors and the corporation and allowed a member of the association credit

for a reasonable salary for the purpose of determining the profits of the firm. This determination was upheld and approved on appeal even though the reasonable salary allowed was greater than the specific figure provided by the employment contract.

In *Jones v. Jones*, 254 Ky. 475, 71 S. W. 2d 999, the partnership agreement provided that one partner should have the acting management of the business and should be paid a reasonable sum for his services. The court there upheld a determination of the reasonable value of the services rendered by the managing partner.

In *Strattan v. Tabb*, 8 Ill. App. 225, it was held that where an agreement for special compensation to one co-partner did not fix the amount of such compensation that the partner was entitled to the reasonable value of his services to the firm.

In *Sears v. Munson*, 23 Iowa 380, without deciding whether the relationship between the partners was a partnership, the court concluded that there had been a definite understanding or agreement that one member of the association should be paid, and held that in the absence of any agreement on a specific amount, the law would fix the amount at what was reasonable.

b. *The Trial Court Erred in Disallowing as a Credit Against the Judgment for Conversion the \$57,200.00 Advanced by Sheldon to the Trailer Business.*

This point, too, has been argued well and thoroughly in the opening briefs of Robert Hohly and the Security-First National Bank of Los Angeles, as Executor of the Will of Ben H. Sheldon, Deceased, and Appellant Mae

Sheldon joins in and adopts as a part of this brief the argument and points and authorities set forth on this point in the said opening briefs. The additional remarks are intended merely to supplement the argument of Robert Hohly and said bank.

Supplemental Findings of Fact 10 and 11 [Supplemental Transcript of Record after Remand, p. 604] relating to the advance of \$57,200.00 are totally unsupported by the evidence. During the proceedings after remand no further evidence whatsoever was introduced by the parties on this matter. Furthermore, this matter was argued at length on the first appeal in the briefs filed by both Appellants and Appellees, and the opinion of the United States Court of Appeals rightfully decided this matter adverse to the Appellee. This matter was again argued by the Appellees in their petition for rehearing and was again rejected by the court of appeals. The trial court's above mentioned Supplemental Findings 10 and 11 are a re-statement of facts and argument already made by Appellee on the first appeal and are contrary to the law of the case.

c. *Summary.*

It is respectfully submitted that contrary to the express provisions of the opinion of the United States Court of Appeals the trial court again erred in its judgment for conversion by failing to give Sheldon credit for the reasonable value of his personal services rendered to the partnership and by failing to give Sheldon credit for \$57,200.00 loaned to the partnership. These were two of the principal points urged on appeal by the Appellants. These points were thoroughly covered in the briefs of all parties, were argued extensive-

ly by all counsel at the time the matter was orally argued before the United States Court of Appeals, and in our opinion the law of this case as established by the opinion of the United States Court of Appeals upon this first appeal required the trial court to determine the reasonable value of services rendered by Sheldon to the partnership and to diminish the judgment for conversion by allowing a credit for the reasonable value of such services and the \$57,200.00 loaned by Sheldon to the partnership.

Appellant Mae Sheldon approves the computation contained in the argument of Robert Hohly and of the Security-First National Bank of Los Angeles, as Executor of the Will of Ben H. Sheldon, Deceased, and submits that the judgment for conversion should be reduced to the amount computed and set forth in said argument of said bank and Robert Hohly.

B. The Judgment Against Mae Sheldon in the Sum of \$55,000.00 Is Not Sustained by the Findings of Fact or the Evidence.

1. Introductory.

The second judgment rendered by the trial court and from which the first appeal was taken provided as follows:

“It is Hereby Ordered, Adjudged and Decreed:

That the plaintiff, Walter A. Lutz, do have and recover judgment against defendants Mae Sheldon, Robert Hohly, James G. Thompson and Flamingo Trailer Manufacturing Corporation, a corporation, and against defendant Security-First National Bank of Los Angeles, as Executor of the Will of Ben H. Sheldon, Deceased, payable by said bank in the due course of administration of said

estate, for the sum of \$31,566.45; and against defendant Mae Sheldon for the additional sum of \$15,000 compensatory damages; * * *.”

The judgment now appealed from, being the third judgment rendered by the trial court, adjudges:

“The plaintiff, Walter A. Lutz, do have and recover judgment against the defendants as follows:

(1) As against the Security First National Bank, as Executor of the Will of Ben H. Sheldon, Deceased, for conversion, in the sum of \$31,566.25, together with interest thereon at seven per cent (7%) per annum from December 10, 1959, to the date of payment, to be paid in the due course of administration of such Estate;

(2) As against Mae Sheldon, for conversion and constructive fraud, in the sum of \$55,000, less any principal sum actually received by plaintiff pursuant to (1) of this judgment, by way of mitigation * * *.” [Supplemental Transcript of Record after Remand, p. 609.]

The manner in which the trial court reached its last judgment against Mae Sheldon is not entirely clear. No evidence whatsoever was introduced during the proceedings before the trial court after remand following the decision of the United States Court of Appeals which would in the slightest degree increase the additional liability of Mae Sheldon for \$15,000 expressed in the second judgment. Instead, all the evidence introduced upon the matter relating to the reasonable value of the services of Ben Sheldon should have reduced the amount of the judgment theretofore rendered against her for conversion. But, as pointed out

above in this brief, the judgment for conversion against Mae Sheldon and the Security-First National Bank was again fixed in the identical amount as set forth in the second judgment which was appealed from and set aside. This judgment for conversion was in the principal amount of \$25,217.07 and interest thereon from the date of the said conversion to December 10, 1959, which brought the principal amount to \$31,566.25.

The judgment in the sum of \$55,000.00 against Mae Sheldon may be diminished by any "*principal sum actually received by plaintiff pursuant*" to the judgment rendered against the Security-First National Bank, as Executor of the Will of Ben H. Sheldon, Deceased, by way of mitigation. The principal amount of the judgment for conversion was \$25,217.07. [Tr. p. 181.] When this is subtracted from the amount of \$55,000.00, we readily see that the trial court has now rendered judgment against Mae Sheldon for an additional sum of \$29,782.93 (\$55,000.00 less \$25,217.07). If we regard the word "principal sum" as used in the judgment of the court to mean the sum of \$31,566.25, then the additional judgment against Mae Sheldon would be \$23,433.75. We submit that this judgment is contrary to the law of the case as determined by the United States Court of Appeals in its opinion on the first appeal, and that the Findings of Fact and Conclusions of Law purporting to justify this judgment are not substantiated by the evidence.

The additional judgment against Mae Sheldon in the sum of \$15,000 from which the first appeal was taken was based upon the additional detriment suffered by Walter Lutz and benefits and advantages obtained by Mae Sheldon as a result of her constructive fraud.

In its opinion the United States Court of Appeals stated:

“It does appear that Sheldon received salary and expenses from the corporation. If consent to incorporation, executed by Lutz, is to be regarded as equitably set aside, then some question may well be raised as to the reasonable value of the services rendered by Sheldon and the amount of compensation to which he was entitled; and as to whether additional benefit was received to which the Sheldons can show no equitable right.” (297 F. 2d 165.)

The judgment against Mae Sheldon in the additional sum of \$15,000 was then set aside and the matter remanded for further findings with reference to the reasonable value of services rendered and expenses properly incurred.

2. The Judgment in the Sum of \$55,000 Is Not Sustained by the Findings of Fact Relating to Alleged Secret Profits and Unjust Enrichment.

After the proceedings upon remand and by its Supplemental Finding of Fact 12 [Supplemental Transcript of Record after Remand pp. 604-605] the trial court found that the Sheldons had obtained the following secret benefits from the partnership and corporation:

- (a) \$80,352.42 in profit-sharing salaries;
- (b) \$14,814.00 in unaccounted-for expenses;
- (c) \$11,161.33 profit on the GSA contract;
- (d) The shifting of \$78,571.88 oil losses incurred by Sheldon and recorded upon the trailer venture's records;

- (3) The deficiency between the Sheldons' capital contribution obligation and their actual investment.

Said Finding 12 is not sustained by the evidence.

Appellant Mae Sheldon will discuss each item of alleged secret benefit separately.

All the foregoing matters were included in the original Findings of Fact made by the court in support of the judgment from which the first appeal was taken. Such findings are set forth in the Appendices annexed hereto.

The profit-sharing salaries in the sum of \$80,354.42 was included in Finding 35 [Tr. p. 215] and Finding 39 [Tr. pp. 218-220]. Appendix 5.

The unaccounted-for expenses in the sum of \$14,814.00 was likewise in Finding 35 [Tr. p. 215] and Finding 39. [Tr. pp. 218-220.] Appendix 5.

The \$11,161.33 profit on the GSA contract was included in Finding 39. [Tr. pp. 218-220.] Appendix 2.

The oil losses of \$78,571.88 was the subject matter of subparagraph 6 of Finding 39 [Tr. p. 218] and Finding 36(f)(3) [Tr. p. 216.] Appendix 9.

All of the foregoing matters were argued in the briefs of the respective parties and considered by the court on the first appeal.

However, it seems advisable to again reiterate and restate the facts and arguments heretofore made, and Appellant Mae Sheldon will discuss these matters in the order followed in the reply brief of Appellant Mae Sheldon filed on the first appeal:

(a) *The Profit On the GSA Contract (\$11,161.33).*

Other than the above-quoted Supplemental Finding of Fact 12, the other Findings of Fact which relate in any way to this item are set forth in Appendix 2 annexed hereto. The principal evidence produced in the transcript relating to this item is likewise set forth in Appendix 3 annexed hereto and may be summarized as follows:

A government contract for the manufacture of trailers was obtained by Western Mobile Homes Distributors Corporation. During the performance of this contract the limited partnership, B. H. Sheldon Co. was formed and succeeded to the business of Western Mobile Homes Distributors Corporation. The partnership completed the contract for Western Mobile Homes Distributors Corporation and Western Mobile Homes Distributors Corporation collected the proceeds from the Government, retaining 5% of the sales to the Government under the contract for the period from June 1, 1954, to the completion of the contract. The net profit from the contract amounted to \$11,161.33 and on January 17, 1955, Western Mobile Homes Distributors Corporation drew a check for this amount to B. H. Sheldon, who in turn deposited this sum in the bank account of the limited partnership and said amount was credited to capital account of B. H. Sheldon and Mae Sheldon. It is clear that the entire sum of \$11,161.33 went into the bank account of the limited partnership.

The sole question involved in connection with this item was whether all or any part of this sum should have been credited to the capital account of B. H. Sheldon and Mae Sheldon. We submit that since the

entire funds went into the bank account of the limited partnership and no part thereof was ever withdrawn and paid out to B. H. Sheldon or Mae Sheldon that the only significance of this transaction is the effect, if any, that it has upon the contentions of the Estate of B. H. Sheldon, deceased, and Mae Sheldon that upon the incorporation of the partnership the general partners were entitled to a greater percentage than 60% of the shares and debentures issued for the transfer of the assets of the partnership. But since the trial Court has held that the general partners were entitled to no increase above 60% in their share of the corporation and has rendered a judgment for the conversion of shares and debentures to which plaintiff was entitled, any damage suffered by the plaintiff has been fully compensated for and covered by the judgment for conversion.

The said sum of \$11,161.33 though credited to the capital account of the general partners was not included in the sum of \$57,200.00 which was loaned by Sheldon to the trailer business. (See Appendix 4.)

To summarize the foregoing, Appellant Mae Sheldon contends:

(a) That said sum of \$11,161.33 was deposited in the bank account of the partnership and has remained there.

(b) That no part of said sum was ever "siphoned off from the partnership or corporation into the pockets of the Sheldons" so as to make her liable as a constructive trustee.

(c) That any damage which might have resulted from this transaction to the plaintiff Lutz was fully compensated for in the judgment for conversion.

(b) *Expense Allowance \$14,814.00.*

Other than the above-quoted Supplemental Finding of Fact 12, the Findings of Fact relating to this item are set forth in Appendix 5 annexed hereto, and the evidence in the record relating to this item (excluding the evidence adduced on proceedings after remand) is set forth in Appendix 6 annexed hereto. Such evidence, including the evidence set forth in the Reporter's Transcript of the proceedings on March 19, 1962, may be briefly summarized as follows:

Exhibit 207 [Tr. 1110] prepared by the witness Donald R. Vilee itemizes the expenses paid to Ben Sheldon, as follows:

| | |
|--|-------------|
| "Expense Allowances: | |
| September 9, 1954 | \$ 500.00 |
| August 9, 1954 | 100.00 |
| December 23, 1954 | 2,214.00 |
| March 17, 1955 | 2,000.00 |
| 10 Months at Rate of \$1000 per month | 10,000.00 |
| | <hr/> |
| | \$14,814.00 |

Mr. Vilee testified that he included the foregoing sums in his statement of known benefits [Ex. 207] because "I did not see any documents that would substantiate that there were any business expenses in that period sustained by Mr. Sheldon or Mrs. Sheldon", and "also by reason of the fact that they were in round thousand amounts per month." He examined the minutes of the corporation and "did not see anything therein about expenses."

After remand, the witness Merryfield testified [Rep. Tr. March 19, 1962, pp. 14-28] that he worked with

Ben Sheldon every day; that Ben Sheldon was the chief executive officer of the company; that Ben Sheldon handled the sales to distributors and dealers entirely; that Ben Sheldon negotiated the contracts with the dealers; that he entertained the dealers when they called at the plant.

From the foregoing it is clear that there is no evidence whatsoever that the sums so paid to Ben Sheldon were used for other than business purposes. Mr. Villee himself testified as follows:

“Q. Do the books and records of the corporation reflect that those expense allowances were utilized by Mr. Sheldon or Mrs. Sheldon for non-business purposes? A. No, they do not reflect that they were not used for business purposes.”
(Appendix 6.)

From the nature of the duties performed by Ben Sheldon it is obvious that from time to time he would be called upon to travel, to entertain and otherwise incur out-of-pocket expenses expected of the chief executive officer of the largest trailer manufacturing business on the west coast.

We submit that the evidence falls far short of sustaining a judgment against Mae Sheldon for 9% of the expense allowances drawn by her deceased husband.

(c) *Salaries Recorded \$80,352.42.*

From February 1, 1955 to May 8, 1956 the following salaries were paid to Ben Sheldon and Mae Sheldon by the corporation:

February 28, 1955 (1 month) \$4,776.07 to Ben Sheldon

February 29, 1956 (12 months) \$72,076.36 to Ben Sheldon

May 1956 (2 months) \$3,500.00 to Mae Sheldon

Total \$80,352.42

The various Findings of Fact relating to the foregoing matter are set forth in Appendix 7 annexed hereto. The principal evidence in the transcript filed on the first appeal relating to the reasonable value of these services is set forth in Appendix 8 annexed hereto.

After remand, the proceedings held on March 19, 1962, were primarily concerned with testimony relating to the reasonable value of the services rendered by Ben Sheldon. This testimony has been thoroughly summarized in the opening briefs of Robert Hohly and the Security-First National Bank.

For our purposes, we again here set forth the testimony of the three witnesses as to the reasonable value of the services for the thirteen-month period February 1, 1955, to March 3, 1956, for which Ben Sheldon was paid \$76,852.43.

| | |
|--------------|----------------------|
| James Harner | \$70,000 |
| Page Galsan | \$77,000 |
| Robert Hohly | \$70,000 to \$90,000 |

If we accept the lowest opinion of \$70,000, then Ben Sheldon was overpaid \$6,852.43 and Walter Lutz suffered a detriment of \$616.72—9% of said sum.

However, the Supplemental Findings of Fact made by the trial court are entirely unsupported by the evidence.

The opening briefs of Robert Hohly and the Security-First National Bank have adequately demonstrated this fact. We agree with and adopt their argument.

No testimony was introduced with respect to the reasonable value of the services rendered by Mae Sheldon.

On March 5, 1956, Mae Sheldon was elected president of the corporation and her salary was fixed by the board of directors at \$3,500.00 per month [Tr. 722, 723]. She served as president until her resignation on May 9, 1956, and during her employment spent every working day at the plant [Tr. 770]. She was paid \$3,500.00 for the two month period of her service.

The foregoing record does not sustain the trial court's findings that Ben Sheldon and Mae Sheldon were unjustly enriched in the sum of \$80,352.42.

(d) *Shifting of \$78,571.88 Oil Losses.*

All the Findings of Fact relating to this item are set forth in Appendix 9 annexed hereto. The evidence in the record relating to this matter is set forth in Appendix 10 annexed hereto. This evidence may be briefly summarized as follows:

The minutes of the Board of Directors of the corporation for a meeting on September 1, 1959, contained the following [Tr. 1017]:

Fifth, the President also mentioned that the corporation had acquired certain interests in oil leases and that it was in the corporation's best interest to acquire several others. After discussion, it was resolved that the action of the officers in these and in the management of the corporate business be approved by the Board and that the officers be commended for the splendid progress the corporation is making.

Mr. Vilee included in Exhibit 207 the moneys expended on oil exploration as follows:

“Unauthorized Ventures:

Oil Exploration:

| | |
|--|-------------|
| Dry hole costs | \$15,789.70 |
| Intangible Drilling and Development Expense | 62,431.48 |
| Midge Oil Co. Loss | 350.70 |
| | <hr/> |
| | \$78,571.88 |

With respect to the caption “Unauthorized Ventures” Mr. Enright and the court made it clear that it was a mere conclusion of Mr. Vilee and was used only in a descriptive sense. See the testimony and statements in Appendix 1 annexed hereto.

Mr. Vilee testified he concluded the oil exploration was unauthorized because of the partnership agreement. He testified that the corporation paid Mr. Sheldon \$2,500.00 for an interest in an oil well. Mr. Hohly testified that the corporation acquired other oil leases and spent sums in drilling. Mr. Bailey testified that he kept the books on the oil investments of the corporation and also kept separate books for the personal investment of Mr. Sheldon’s oil investments.

The auditor’s report of the corporation as of February 29, 1956 [Ex. 214, Tr. 1135], shows the corporation had investments in oil wells of a value of \$21,000.00.

Based on the foregoing evidence the trial court made its Supplemental Finding of Fact 12 wherein it was found:

“The Sheldons obtained various secret benefits * * *. Among such benefits were * * * the shifting of \$78,571.88 oil losses incurred by B. H. Sheldon and recorded upon the trailer venture’s record. * * *”

This finding is not sustained by the evidence.

In the first place there is absolutely no evidence that the funds of the corporation were being spent upon oil lands owned by B. H. Sheldon or Mae Sheldon. There is no evidence that such moneys were in any manner being expended for the benefit of B. H. Sheldon or Mae Sheldon. The evidence is to the contrary and clearly indicates that if the investments had been profitable the profits would have accrued to the corporation.

There is absolutely no evidence that B. H. Sheldon had incurred oil losses of \$78,571.88 or any other sum and had shifted such loss to the corporation. Certainly there is nothing in the record to show that Mae Sheldon was unjustly enriched by the moneys expended by the corporation on oil investments.

It must be remembered that Mae Sheldon was neither an officer or director of the corporation at the time the investments in oil wells were being made. Therefore, even assuming that it was wrongful for the corporation to make the investments in the oil wells, Mae Sheldon cannot be personally charged with the re-

sponsibility therefor. She can be charged only with that which she receives and which unjustly enriches her. In *Ward v. Taggart*, 51 Cal. 2d 736, the defendant Taggart was held to be “an involuntary trustee for the benefit of plaintiffs on the secret profit of \$1,000 per acre that he made from his dealings with them “while the judgment against the defendant Jordan was reversed because

“Although she permitted her name to be used in the dual escrows, she did not share in the illicit profit that Taggart obtained. *One cannot be held to be a constructive trustee of something he has not acquired.*”

The evidence relating to oil investments falls far short of sustaining the finding that the Sheldons were unjustly enriched in the sum of \$78,571.88. In fact, the auditor’s report [Ex. 214, Tr. 1135] clearly shows that 52% of the “oil losses” would otherwise have been paid to the Federal Government as corporate income tax, and 4% would have been paid to the State of California as corporate franchise tax. Therefore, while Mae Sheldon and Ben Sheldon were not enriched in any sense whatsoever, the actual detriment suffered by Walter Lutz by reason of speculation in oil would be only 1/9th of 44% of the said sum of \$78,221.18.

3. The Judgment for \$55,000 Is Not Sustained by the Findings of Fact Relating to the Capitalization of Profits.

By the last paragraph of Supplemental Findings of Fact No. 12 [Supplement Transcript of Record after Remand, p. 605, lines 15-32] the trial court attempts to justify the judgment of \$55,000 by presenting again the argument for valuing the 9% interest of Walter Lutz by capitalizing the past and future earnings of the trailer business. He thus values the plaintiff's misappropriated interest at \$126,760.27.

The foregoing is clearly contrary to the law of the case as determined by the opinion of the court of appeals. This matter was argued at length in the briefs filed on the first appeal (Appellee's Consolidated Brief, pp. 43, 44, 110-113, Reply Brief of Mae Sheldon, pp. 11-17) and was again strenuously argued in oral argument before the Court of Appeals.

In response to such argument the opinion of the Court of Appeals ruled as follows:

“In opposition to the bank's contentions, Lutz argues that under California law he is entitled, subject to the court's judgment, either to the value of the converted property or to all damages proximately caused by the conversion. Further he contends that under California law it is proper, in assessing damages, to take into consideration past and projected profits of which he has been deprived. He asserts that were such matters taken into con-

sideration by the district court they may well have offset the sums due Sheldon.

“But the value of the business reflects the prospective profits of that business. The price paid to the bank by Thompson, under recognized business practice, must have been based in part upon a capitalization of such prospective profits. What Lutz is here saying in effect is that the district court may well have felt that Thompson’s rate of capitalization was inadequate and that the purchase price therefore did not truly reflect the value of the property converted. The record does not bear this out. In accordance with Lutz’ own proposal, damages were computed by the court upon the value as of May 8, 1956, of the property of Lutz converted by the bank as established by the sum for which it was sold by the bank.”⁴

The foregoing excerpt plainly states the law of this case and effectively disposes of the argument for capitalization of past and future earnings.

4. Supplemental Finding of Fact No. 14 Is Not Sustained by the Evidence or Supported by the Pleadings.

In Supplemental Finding of Fact No. 14 [Supplemental Transcript of Record after Remand, p. 606, lines 2-6], the trial court found as follows:

⁴The estate of Sheldon was directed to give up what the court regarded as unjust enrichment. This itself is wholly inconsistent with the proposition that (although it was a nonfraudulent converter) it should be held liable for more than that which it had itself realized.”

(297 F. 2d 162, 163.)

“14. Fair compensation to plaintiff for the time and money properly expended by plaintiff in pursuit of the property converted is the sum of \$3,310.07, which was reasonably and necessarily incurred by plaintiff for accounting services and expenses.”

Plaintiff is not entitled to recover any portion of the accounting fees of Mr. Vilee for the reasons hereinafter set forth:

(a) *There Is No Pleading to Support a Recovery of the Accounting Fees, or Any Portion Thereof.*

The amended complaint [Tr. pp. 10-70] contains no allegation supporting this element of special damages.

The amended pre-trial conference order [Tr. pp. 153-158] makes no mention of the claim.

It is well-settled that such special damages must be properly pleaded and proved in order for a recovery to be made. In speaking of such special damages arising from a conversion, American Jurisprudence (53 Am. Jur. 896) states:

“The general rule is that special damages, which have been defined as such damages as arise from the special circumstances of the case, *which, if properly pleaded*, may be added to the general damages which the law presumes or implies from the mere invasion of the plaintiff's rights, may be recovered in an action for conversion, * * *

Obviously, plaintiff cannot recover against Security First National Bank, as Executor of the Will of Ben-

jamin Harrison Sheldon, deceased, for such item of special damages unless it was included in the claim filed with the Executor. This was not done. [Tr. pp. 67-70.]

The plaintiff cannot recover against any other defendant for this item of special damages unless it was properly pleaded. This was not done. Defendants cannot be expected to be prepared to meet issues which are not included within the pleadings filed by the parties.

The consideration of this matter was wholly outside the mandate of the United States Court of Appeals as expressed in its opinion on the first appeal.

Apparently the plaintiff had some misgivings about the propriety of this item of special damages and about Supplemental Findings of Fact 12, because after the Revised Judgment was made, plaintiff filed his Notice of Application for Costs and Cost Bill, wherein he sought to have accounting fees in the sum of \$3,310.07 taxed as costs. [Supplemental Transcript of Record after Remand, p. 610.] This application was denied by the clerk and plaintiff made a Motion to Re-Tax Costs, which was denied by the trial court. [Supplemental Transcript of Record after Remand, p. 628.]

(b) *The Accounting Fees of Mr. Villee Do Not
Constitute a Proper Item of Special Damage.*

At the hearing on March 19, 1962, after remand, Mr. Villee testified to the value of his services and his invoice therefor was introduced in evidence as Exhibit 222.

Exhibit 222 represents the statement of the fees owing to Mr. Villee for accounting services rendered to Mr. Joseph Enright from August 11, 1957, to and including June 19, 1959, in the total sum of \$4,157.57. Exhibit 222 shows that the services of Mr. Villee did not start until August 1957. The record clearly and plainly demonstrates that the services of Mr. Villee cannot qualify as "money properly expended in pursuit of the property" as stated in Section 3336 of the California Civil Code.

The creditor's claim filed by Walter A. Lutz against the Estate of Ben Sheldon, deceased, was verified by Mr. Lutz on October 15, 1956. [Tr. p. 70.] In this claim the plaintiff, Walter A. Lutz, alleged and claimed that the Executor held in trust for him 390.98 shares of the capital stock of B. H. Sheldon Company, together with debentures in the amount of \$6,341.45. This claim demonstrates that at least on October 15, 1956, the plaintiff, Walter Lutz, had identified the exact number of shares and the amount of the debentures to which he was entitled and he knew the exact location of said additional shares and debentures, namely, in the possession of the Security First National Bank, as Executor of the Estate of Ben Sheldon, deceased. There was no need for any further expenditure of time and money in pursuit of the shares of stock and debentures, which constitute the subject matter of the conversion. The said shares and debentures were sold by the said Executor and Mae Sheldon to James G. Thompson on or about May 8, 1956. The sale of the said shares and debentures

was confirmed by the Probate Court on or about June 26, 1956 [Tr. p. 161] and obviously at the time of the filing of the creditor's claim the facts of the conversion of the shares of stock and debentures were well-known to the plaintiff, who subsequently prepared and filed his creditor's claim therefor.

On June 14, 1957, plaintiff Walter Lutz sold to Flamingo Trailer Manufacturing Corporation the shares of stock and debentures originally issued to him. It is clear that Mr. Lutz was then well-advised of the value of the shares and debentures allegedly converted, for he later adopted and stipulated that the price of the shares and debentures sold to Flamingo Trailer Manufacturing Corporation represented the value of the shares and debentures allegedly converted by the defendants. The creditor's claim was verified and filed approximately ten months prior to the employment of Mr. Villee and plaintiff's sale to Flamingo Trailer Manufacturing Corporation also occurred prior to the employment of Mr. Villee.

Thus, there is no factual basis to show that the accounting fees of Mr. Villee were expended by the plaintiff in pursuit of the property.

(c) *The Record Amply Demonstrates That the Accounting Fees of Mr. Villee Were Expended for the Purpose of Preparing Testimony to Be Given at the Trial, and for Purposes Entirely Unrelated to the Provisions of the Second Paragraph of Section 3336 of the California Civil Code.*

All of the services expended by Mr. Villee in the preparation of Exhibit 210 [Tr. p. 1110] and the ex-

amination of the records of Flamingo Trailer Manufacturing Corporation, from which such items were taken, are entirely concerned with the attempt to establish a basis for a judgment against the defendant Mae Sheldon, in addition to the judgment for conversion of shares of stock and debentures.

It is clear from the testimony of Mr. Villee at the last hearing in Court that Exhibit 222 represents charges for services in preparation of exhibits and in testifying as an expert witness at the trial of the above matter. The moneys for such fees clearly cannot be said to be "properly expended in pursuit of the property."

It is respectfully submitted that a perusal of the testimony given by Mr. Villee at the trial will clearly demonstrate that the fees paid to him were not "moneys properly expended in pursuit of the property," as referred to in Section 3336 of the California Civil Code.

The burden of proving this element of special damages is upon the plaintiff and the testimony of Mr. Villee did not furnish clear and definite proof of what portion of his services, if any, were properly required in order to pursue the property allegedly converted. The proof and evidence in the instant case is no better than that in *Sherman v. Finch*, 71 Cal. 68, where the Court said (pp. 71-72):

"But the evidence the court permitted the plaintiffs to give for the purpose of entitling them to compensation for time and money expended in pur-

suit of the property was not proper, and defendant's motion to strike the same out should have been granted. It was altogether too indefinite and uncertain. To entitle a party to such compensation the testimony should tend to show that money was properly paid out and time properly lost in pursuit of the property, and how much. And when that is done, it is for the court or the jury, as the case may be, to allow a fair compensation therefor."

It is respectfully submitted that the pleadings and the evidence do not justify the recovery by the plaintiff of any portion of the accounting fees paid to Mr. Villet as a part of the damages for the alleged conversion. Such fees are clearly not taxable as costs.

"The general federal rule is that the compensation paid to an expert witness in excess of the statutory attendance fee of \$4.00 per day, mileage, and subsistence allowance when warranted is not taxable." (*Moore's Federal Practice*, 2d Edition Vol. 6, 1367.)

Summary.

1. As to Judgment for Conversion.

Under the law of this case as established on the first appeal, Mae Sheldon submits that the trial court again erred in that its determination of the damages for conversion failed to give credit for

(1) the \$57,200.00 loaned by Ben Sheldon to the partnership, and failed

(2) to give credit for the reasonable value of Ben Sheldon's services to the partnership.

Clearly, the rendition after remand, of a judgment for conversion in the same amount of the judgment reversed on appeal was erroneous. This judgment should once again be set aside. Perhaps the proper procedure would require the matter to again be remanded to the trial court with instructions. However, we join with the other appellants and urge the United States Court of Appeals to determine the proper amount of the damages for conversion and issue a remittitur accordingly. This procedure was substantially followed in *Alexander v. Nash-Kelvinator Corporation*, 261 F. 2d 187 (2nd Cir. 1958) and 271 F. 2d 524 (1959), where the trial court after remand fixed damages in the same sum as before.

We believe this same procedure would be welcomed by the trial court in the instant case. In making its Supplemental Findings the court said,

“However, the Court intends to find all of the relevant facts, so that if its construction of the mandate is in error, a further remand will be unnecessary.” [Supplemental Transcript of Record After Remand, p. 599, lines 14-17.]

At the hearing on February 19, 1962, the trial court said:

The Court: I am only sorry that the Court of Appeals, having tried part of the case, didn't go ahead and finish it.” [Rep. Tr. Feb. 19, 1962, p. 4, lines 9-11.]

Certainly the expense involved in further litigation justifies the Court of Appeals in making a final determination.

2. As to the Additional Judgment Against Mae Sheldon.

Under the law of the case as established on the first appeal Mae Sheldon is liable to the plaintiff for his share of any additional benefits which Mae Sheldon received from the trailer business to which she can show no equitable right.

The evidence does not sustain the judgment of \$55,000.00. Against the sum of \$55,000.00 will be credited "any principal sum actually received by plaintiff pursuant to" the judgment for conversion. As pointed out earlier in this brief the principal sum of the conversion judgment as adopted by the trial court was \$25,217.07. This leaves a balance of \$29,782.93 which must be supported by evidence of benefits received by Mae Sheldon to which she was not justly entitled. This means that in order to justify a judgment against Mae Sheldon and in favor of Walter Lutz in the sum of \$29,782.93, the record must show that Mae Sheldon was unjustly enriched in the total sum of \$330,921.40, as 9% of \$330,921.40 equals \$29,782.93, the amount of the additional judgment against Mae Sheldon which allegedly is Walter Lutz' share of such unjust enrichment.

The foregoing illustrates the absurdity of the judgment for \$55,000.00 against Mae Sheldon, as even the sum total of all amounts mentioned by the trial court

in its findings as benefits and unjust enrichment of Mae Sheldon does not equal \$330,921.40.

It is respectfully submitted that the trial court has again erred, and the judgment against Mae Sheldon should be set aside. As pointed out above, it is the desire of all appellants to bring this expensive litigation to an end.

We believe the foregoing argument shows that the only benefits actually received by Mae Sheldon or Ben Sheldon which might be the subject matter of an additional judgment against Mae Sheldon are (1) salaries in excess of the reasonable value thereof, and (2) improper reimbursement for expenses. The record shows that Mae Sheldon was president of the corporation for the two months' period and that she was at the plant every working day and unquestionably rendered some service to the corporation. The record further shows that Ben Sheldon, as executive officer of the trailer business, entertained dealers and distributors and incurred out-of-pocket expenses in the course of his duties. We do not think the sums paid to him are unreasonable and excessive in view of the activities performed by him on behalf of the corporation.

In the interest of procuring a final determination of this matter, we ask the United States Court of Appeals to determine on the evidence the amount of an additional judgment against Mae Sheldon. While we will not concede that any judgment against Mae Sheldon is

justified, for the sake of procuring final settlement of this matter, we will, without waiving the position taken in this brief, consent to the following:

(1) That the court of appeals determine whether or not any excessive salaries were paid to Ben Sheldon and if so the amount of any unjust enrichment of Mae Sheldon as a result thereof;

(2) That the court of appeals likewise similarly determine any unjust enrichment of Mae Sheldon by reason of the salary of \$3,500.00 paid to her for her services as president for two months;

(3) That the court of appeals likewise determine the amount of any unjust enrichment of Mae Sheldon by reason of the expenses paid to Ben Sheldon of \$14,814.00.

We make the foregoing statements to assure this honorable court that the appellant Mae Sheldon will readily accept any final determination made by it in respect to the additional judgment to be rendered against Mae Sheldon.

Respectfully submitted,

GERALD BRIDGES,
Attorney for Appellant Mae Sheldon.

Certificate.

I certify that, in connection with the preparation of this brief, I have examined Rules 18 and 19 of the United States Court of Appeals for the Ninth Circuit, and that, in my opinion, the foregoing brief is in full compliance with those rules.

GERALD BRIDGES



APPENDIX 1.

(Testimony of Donald R. Villee). [Tr. 524]:

Mr. Henigson: To make the record clear—[139]

Mr. Enright: May I finish, if you please?

Mr. Henigson: Sure.

Mr. Enright: I do understand that there may be some difference as to use of some of the words in the exhibits where, for example, I believe the word is—what is that—unauthorized, Exhibit 207 uses the word “unauthorized oil”—I believe, yes—unauthorized ventures.

The Court: That will go down as the conclusion of the accountant.

Mr. Enright: Sure.

The Court: That is one of the questions, I assume, that is here for the court to determine.

Mr. Enright: It is the plaintiff's intention that that matter be settled by the court.

The Court: I see here, on one of these statements of known benefits—

Mr. Enright: I agree that that word, or words are inept, but it is not our intention to have this CPA draw any conclusions, but he has to use some words of identification.

The Court: Well, let's say he uses them in a descriptive sense.

Mr. Enright: That was the intention of the plaintiff, and it is plaintiff's position they are known benefits. But that is for the court to determine.

Now Mr. Henigson, proceed. [140]

APPENDIX 2.

Finding 34 [Tr. 213]:

B. H. Sheldon represented to plaintiff about February 1955, to induce him to consent to the conversion of the trailer manufacturing business from a partnership,
* * * to a corporate venture: * * *

Plaintiff relied upon the said representations and did then consent to the formation of a corporation to carry on the trailer manufacturing business. Each of these representations was made with the intent: * * *
(c) to conceal B. H. Sheldon would appropriate a profit in the amount of \$11,161.36 realized upon the sale of house trailers to the General Services Administration of the United States when converting the trailer business from a partnership to a corporation. * * *

Finding 39 [Tr. 218, 220]:

Concerning defendants' pre-trial order statement of their contentions, the court finds:

* * * (3) It is true a particular separate profit of \$11,161.36 was realized upon the General Services Administration Contract referred to in finding 39(1), which profit was credited by B. H. Sheldon and Robert Hohly to the capital account of B. H. Sheldon and Mae Sheldon. It is also true neither B. H. Sheldon nor Robert Hohly disclosed to plaintiff the entire \$11,161.36 was credited to B. H. Sheldon and Mae Sheldon, who at most were entitled to receive as general partners 60 percent of this profit when profits were distributed under the partnership agreement. It is untrue no injury was

caused to plaintiff because of this transaction for the reason this \$11,161.36 when credited to the general partners', B. H. Sheldon and Mae Sheldon, capital account was then used as one of the items to partially account for the issuance of 80 percent of the stock and debentures of Flamingo to B. H. Sheldon and Mae Sheldon. It is further true no accounting upon the issuance of these securities was made by B. H. Sheldon, Mae Sheldon or Robert Hohly or any of them to the plaintiff.

Supplemental Finding after Remand 12 [p. 8, lines 29-32, p. 9, lines 1 and 2, Supplemental Transcript of Record on Appeal after Remand]:

"12. The Sheldons obtained various secret benefits from B. H. Sheldon's control of the partnership and later the Corporation, all of which were concealed from plaintiff, a limited partner. Among such benefits were \$80,352.42 in profit-sharing salaries, \$14,814 unaccounted for expenses, the \$11,161.33 profit on the G.S.A. Contract, * * *"

APPENDIX 3.

(Testimony of Donald R. Villee). [Tr. 547]:

By Mr. Henigson:

Q. Would you turn to account No. 102 in the books of B. H. Sheldon Co., a partnership?

A. I have it.

Q. You have an item there, January 17, 1955, posted in what sum?

A. There is no entry here dated January 17, 1955, Mr. Henigson.

Q. May I see the book, please?

(The exhibit referred to was passed to counsel).

By Mr. Henigson:

Q. The record to which you were referring is account No. 102 marked "Notes Payable" and I should have been more specific in my identification of the page.

I show you now the same book, account No. 170.9 and ask you whether there is a January 17th entry there for 1954?

A. (Examining exhibit).

Q. Excuse me. 1955.

A. Yes, there is.

Q. In what sum?

A. In the amount of \$11,161.36.

Q. And that account purports to be what? [167]

A. The capital of B. H. Sheldon, general partner.

Q. And the posting was made from what page?

A. From the cash received register, 1.

Q. And does the cash received register 1 so reflect that \$11,161.36 in cash came into the partnership on January 17, 1955?

A. I have not that ledger here, but I believe that it does.

(Testimony of Donald R. Villee). [Tr. 549-552]:

Q. Would you like to see it?

Mr. Enright: He can check his notes.

Mr. Henigson: I would prefer to hand him the book.

(The exhibit referred to was passed to the witness).

By Mr. Henigson:

Q. This is page No. CR-1, January 1955.

A. (Examining exhibit). Yes, there is an entry here in that amount.

Q. It doesn't seem to appear in Plaintiff's 204 for identification? A. No, it does not.

Q. Is there any reason from your inspection of the books and records only why it does not so appear?

A. That is an amount that was obtained from Western Mobilehomes Distributors Corporation.

Q. And the books of Western Mobilehomes Distributors [168] Corporation reflect that fact?

A. Yes, a payment to B. H. Sheldon in that amount.

Q. To B. H. Sheldon in that amount?

A. Yes, sir.

Q. And the cash was deposited to B. H. Sheldon Co., a partnership, according to the record you just read?

A. That is correct.

Q. On January 17, 1955 and then posted to the capital account of B. H. Sheldon, but it doesn't seem to be reflected on Plaintiff's 204. Why not?

A. I have examined—

Q. Based on your inspection of the books and records only.

A. One of the records which inspected, Mr. Henigson, was the partnership agreement.

Q. The reason that you did not post in your Plaintiff's 204, or include in Plaintiff's 204 for identification the sum of \$11,161.36 is what?

A. I examined the partnership agreement which stated that the general capital, or rather the capital of the general partners, was to consist of all the assets and liabilities of Western Mobilehomes Distributors Corporation. This \$11,000 represents the net profits on sales of Government contracts from June 1, 1954 forward which, in my opinion, represented profits belonging to the partnership and not therefore a contribution of B. H. Sheldon.

* * * * *

(Testimony of Donald R. Ville). [Tr. 575]:

Q. Now going on to your sheet No. 5 which has been marked Plaintiff's Exhibit 207 for identification—

A. Yes.

Q. —I see you start out with the sum of \$11,161.33 as a withdrawal of funds, not profit on Government sales to Western Mobilehomes Distributors Corporation.

The Court: This sheet has no relationship to the others, does it?

The Witness: Not directly, your Honor, no. Each schedule stands for a specific purpose on its own.

The Court: The exhibit I am referring to is Exhibit 207 for identification.

Mr. Henigson: Yes, your Honor.

Q. Withdrawal of funds from what entity?

A. From Western Mobilehomes Distributors Corporation.

Q. And where did that cash withdrawal appear in the books and records of the corporation?

A. As a journal entry, Mr. Henigson.

The Court: It is already explained under the source of information. Haven't you checked that?

Mr. Henigson: That is where it was withdrawn from, your Honor, January 17, 1955 journal entry. I want to know [202] whether that same sum appeared on the same day in another book or record that Mr. Villee inspected.

The Court: Was it evidenced by check? It says check 1060. Is that what you mean?

Mr. Henigson: Yes, your Honor.

The Court: There is a check for \$11,161.33, I take it, drawn on the Western Mobilehomes Distributors Corporation.

Mr. Henigson: Drawn by Western Mobilehomes Distributors Corporation.

The Court: Payable to Sheldon?

Mr. Henigson: Well, that is a question?

The Court: Was it? Do you have the check?

Mr. Henigson: I don't, your Honor.

The Court: Do you know anything about the check?

The Witness: I never saw the check, your Honor.

The Court: What do the books show?

The Witness: The books showed that check No. 1060 dated January 7th was payable to B. H. Sheldon.

The Court: Very well. Did it appear to have been deposited anywhere, is that your question, deposited back in either the corporation or the partnership?

The Witness: Yes, it was deposited in B. H. Sheldon Co. partnership books.

The Court: Was it deposited in B. H. Sheldon's [203] partnership bank account?

The Witness: I am sorry, your Honor. Your terminology is correct.

The Court: Was it?

The Witness: It was recorded as a cash receipt. We referred to it earlier.

The Court: As part of his capital contribution, is that correct?

The Witness: Yes, your Honor.

By Mr. Henigson:

Q. It does not appear in any of the personal commercial bank accounts that you inspected, or statements, for Mr. B. H. Sheldon, does it?

The Court: As I understand it, the opinion of the witness is that these were profits belonging to the partnership. That is his theory. The corporation owned them to the partnership. Instead of drawing a check to the partnership the corporation drew a check to Sheldon individually, Sheldon deposited it in the bank account of the partnership but claimed credit for it as a capital contribution as a general partners in the partnership. Is that correct?

The Witness: That is exactly correct.

(Testimony of Donald R. Villee.)

The Court: You may proceed.

See also Exhibits 183, 184 [Tr. 1032, 1033.]

APPENDIX 4.

(Testimony of Donald R. Villee) [Tr. 793, 794]:

Mr. Henigson: I think we can stipulate on that. I will [519] offer the stipulation that between the period July 12, 1954, to and including January 25, 1955, cash contributions were made by the decedent in the total sum of \$67,200, of which \$10,000 was repaid to him on about August 9, 1954.

Mr. Enright: That will be accepted. So the net amount then is \$58,200?

Mr. Henigson: \$57,200 in cash contributions during that period, now.

The Court: Very well.

Mr. Enright: In addition to the cash contributions, there is shown \$11,161.36, being the General Services Administration 5 per cent.

Mr. Henigson: I will stipulate to that.

Mr. Enright: All right.

APPENDIX 5.

Finding 35 [Tr. 215]:

B. H. Sheldon did conceal from plaintiff when consummating the corporate conversion * * * (e) that B. H. Sheldon had during the period about January 1955, to March 1956, obtained \$80,352.42 as salary for services and had obtained the sum of \$14,814.00 as expenses.

Finding 39 [Tr. 218]:

Concerning defendants' pre-trial order statement of their contentions, the court finds:

* * * (4) It is true B. H. Sheldon received salaries in the sum of \$80,352.42 and expenses in the sum of \$14,814.00. It is also true B. H. Sheldon was by the provisions of paragraph 23 of the partnership agreement [Exhibit A of these findings] to be paid such reasonable compensation for services rendered in operating the business as were agreed upon by the general partners and a majority in interest of the limited partners. It is also true no such agreement upon the salary of B. H. Sheldon was ever made. On the contrary, these salaries and expenses were taken by B. H. Sheldon without the knowledge or consent of the plaintiff, the only knowledge plaintiff had of a desire of B. H. Sheldon to be paid a salary is as found in paragraph 34 hereof.

Supplemental Finding after Remand 1(b) [P. 4, lines 19-23, Supplemental Transcript of Record on Appeal after Remand]:

“(b) Defendants have never attempted to substantiate or prove the propriety of \$14,814 drawn by B. H. Sheldon as ‘expense allowance’. Such unsubstantiated withdrawals by Sheldon cannot be presumed to be ‘properly incurred’.”

Supplemental Finding after Remand 12 [P. 8, lines 29-32, p. 9, line 1, Supplemental Transcript of Record on Appeal after Remand]:

“12. The Sheldons obtained various secret benefits from B. H. Sheldon’s control of the partnership and later the Corporation, all of which were concealed from plaintiff, a limited partner. Among such benefits were \$80,352.42 in profit-sharing salaries, \$14,814 unaccounted for expenses, * * *”

APPENDIX 6.

(Testimony of Donald R. Villee). [Tr. 578]:

The Court: You may proceed.

By Mr. Henigson:

Q. Directing your attention to Plaintiff's Exhibit 207, Mr. Villee, you have now there a total of expense allowances of \$14,814 covering the period September 9, 1954 through what, ending what? A. It would end February, 28, 1956.

Q. Do the books and records of the corporation reflect that those expense allowances were utilized by Mr. Sheldon or Mrs. Sheldon for nonbusiness purposes? A. No, they do not reflect that they were not used for business purposes.

Q. For what reason do you include that sum in the statement of known benefits which you have entitled in your Plaintiff's Exhibit 207 for identification? A. I did not see any documents that would substantiate that there were any business expenses in that period sustained by Mr. Sheldon or Mrs. Sheldon.

Q. You didn't see any receipts or anything of that nature? A. No, sir.

Q. So you concluded that they were improperly used? A. And also by reason of the fact that they were in round thousand amounts per month. [205]

Q. For a portion of that total period? A. Yes.

The Court: Did you find in any of the minutes of the corporation, or prior to that, the partnership, anything allowing for or authorizing that purchase?

The Witness: No, sir, I did not.

The Court: Did you look for any?

The Witness: I examined the minutes and I did not see anything therein about expenses.

APPENDIX 7.

Finding 34 [Tr. 213]:

B. H. Sheldon represented to plaintiff about February 1955, to induce him to consent to the conversion of the trailer manufacturing business from a partnership, the terms and conditions thereof being set out in Exhibit A to these findings, to a corporate venture: * * * (i) that he, B. H. Sheldon, believed he should receive a salary in the amount of \$1,000 per month for the past services he had rendered to the partnership.

Plaintiff relied upon the said representations and did then consent to the formation of a corporation to carry on the trailer manufacturing business. Each of these representations was false when made, * * *. Each of these representations was made with the intent: * * * (d) to evade the provisions of the Partnership Agreement, * * * (5) the provisions requiring the amount of salary to be paid to the general partners for services rendered to be agreed to by a majority in interest of the limited partners; and * * *

Finding 34 [Tr. 215]:

B. H. Sheldon did conceal from plaintiff when consummating the corporate conversion * * * (e) that B. H. Sheldon had, during the period about January 1955, to March 1956, obtained \$80,352.42 as salary for services and had obtained the sum of \$14,814.00 as expenses.

Finding 39 [Tr. 218]:

Concerning defendants pre-trial order statement of their contentions the court finds: * * * (4) It is true B. H. Sheldon received salaries in the sum of \$80,352.42 and expenses in the sum of \$14,814.00. It is

also true B. H. Sheldon was by the provisions of paragraph 23 of the partnership agreement [Exhibit A of these findings] to be paid such reasonable compensation for operating the business as were agreed upon by the general partners and a majority in interest of the limited partners. It is also true no such agreement upon the salary of B. H. Sheldon was ever made. On the contrary, these salaries and expenses were taken by B. H. Sheldon without the knowledge or consent of the plaintiff, the only knowledge plaintiff had of a desire to B. H. Sheldon to be paid a salary is as found in paragraph 34 hereof. That some time after January 31, 1955, B. H. Sheldon and Robert Hohly, along with R. L. Merrifield, caused to be recorded in the records of Flamingo a director's resolution authorizing the payment of a salary to B. H. Sheldon of 15 per cent of the profits of the trailer business, but in no event less than \$5,000.00 per month. This Court makes no finding as to what salary would be reasonable for the services of B. H. Sheldon because of the other facts found, its conclusions and judgment.

Supplemental Findings after Remand 5, 6, 7, 8 and 9 [pp. 6, 7 and 8 Supplemental Transcript of Record on Appeal after Remand]:

"5. In April, 1955, B. H. Sheldon caused his controlled corporation, Flamingo, to issue him a 'salary' check for \$4,776.07 (10% of profits), in full payment of amounts Sheldon had secretly accrued for himself on the partnership's books as 'accrued payroll' during the period March 18, 1954 to February 18, 1955 (which included the so-called 'partnership period', July 1, 1954 to January 31, 1955) and concealed these acts from his

limited partners. The transfer to the Corporation was motivated, in part, by Sheldon's desire to hide such fraudulent conduct from his partners.

6. Sheldon devoted considerably less than his entire time to the trailer business in the period July 1, 1954 to March 3, 1956. Other persons contributed more importantly to the success of the trailer venture, while Sheldon attended to his gambling club and oil ventures, and, with Hohly's assistance, consummated the misappropriation of the partnership in 1955. Limited partner Eisenhower obtained \$100,000 needed working capital on his own credit from a Tacoma bank, obtained vital raw materials, was instrumental in securing the lucrative G. S. A. contract, and participated in production and sales policy decisions. L. B. McKinney, the factory superintendent who was in charge of production, was paid a salary of 10% of profits, which at one time exceeded \$5,000 per month. Trailers not sold to the Government were sold on commission, Hohly did the necessary cost accounting, and a salaried office staff handled administration, while J. L. Merrifield, an experienced trailer executive, devoted 100% of his time to the business. Viewing the entire record, even apart from any question regarding the burden of proof, I find that B. H. Sheldon's services to the partnership and later the corporation were insubstantial.

7. Based upon all the circumstances, a maximum reasonable salary for B. H. Sheldon's services to the partnership in the seven months, July 1, 1954 to January 31, 1955, would not have exceeded \$600.00 per month, or a total of \$4,200,

even assuming that: (1) in equity Sheldon was entitled to some salary notwithstanding that no agreement had been requested or made pursuant to Paragraph 23 of the partnership agreement; (2) that he did not waive any such claim to salary; and, (3) that he had not already been paid for such services.

The \$4,776.07 salary Sheldon secretly paid himself in April, 1955, for his services to the partnership was excessive for the services he actually rendered, and he was unjustly enriched thereby in the sum of \$576.07, assuming he had an equitable right to any salary at all.

8. Following the transfer of the partnership assets upon the books and records of the trailer venture to the Corporation on February 1, 1955, B. H. Sheldon continued to secretly accrue a salary for himself on the Corporation's books under the legend 'accrued payroll', and from time to time paid himself 'salary' which was debited to such account. Months later, Sheldon's Board of Directors purported to approve such 'salary' retroactively.

9. Based upon all the circumstances, a maximum reasonable salary for B. H. Sheldon's services in the corporation period, February 1, 1955 to March 3, 1956, would have been \$600 per month or \$7,800. The retroactive profit sharing salary Sheldon secretly paid himself was exorbitant, and Sheldon was unjustly enriched thereby in the sum of \$64,276.35—the excess of the \$72,076.35 he paid himself over the \$7,800 found reasonable, assuming he had an equitable right to any salary at all.”

APPENDIX 8.

(Testimony of Walter A. Lutz). [Tr. 392]:

By Mr. Bridges:

Q. Had you learned prior to June 1956. Doctor that Mr. Sheldon was drawing a salary or had received any salary from either the partnership or corporation?

A. I had heard that he was receiving \$5,000 in February of 1956.

The Court: \$5,000 a month?

The Witness: \$5,000 a month.

The Court: Was that the first you had ever heard that he was receiving any salary?

The Witness: Yes, sir.

By Mr. Bridges:

Q. From whom did you receive this information?

A. I first received it from Mrs. Lutz. On that week we were down in '56, it was either a Tuesday—it had to be a Tuesday—Mrs. Sheldon called Mrs. Lutz into the living room and said, “Sit down a minute, Sunny,” and she said to Sunny, “Don’t you think Daddy is entitled to a salary, everybody [128-57] else is getting something,” and Sunny says, “Yes, I do.”

She said, “Well, he is taking \$5,000 a month,” and I guess Sunny was flabbergasted, she didn’t say a word, and she told me about it that same night or so.

Q. What did you do, or did you speak to Mr. Sheldon about that at any time thereafter?

A. I didn’t have an opportunity to talk to him about it.

Q. Do you recall which day of the week that conversation was?

A. With Mrs. Sheldon and Mrs. Lutz?

Q. Yes.

A. I can't recall exactly. It had to be Tuesday or Wednesday.

[Plaintiff's Exhibit 169, Tr. 1014, 1017, 1018]:

Excerpt from minutes of Board of Directors of B. H. Sheldon Company held on September 1, 1955.

"Sixth, Mr. Sheldon noted that the salary of Mr. L. B. McKinney, factory superintendent, was currently based on 10% of the corporation's profits before taxes and he noted that in recent months this salary had been in excess of \$5,000.00 per month. Thereupon, he turned to Mr. McKinney, who had just entered the meeting, and proposed that a flat salary arrangement be worked out with him effective as of July 1, 1955. Mr. Sheldon stated that he felt a monthly salary of \$5,000.00 was a reasonable amount. Thereupon, Mr. McKinney agreed and it was mutually agreed between the Directors and Mr. McKinney that his salary be set at \$5,000.00 per month effective July 1, 1955. This is to supersede the previous agreement.

Thereupon, Mr. Merrifield mentioned that he felt Mr. Sheldon's salary should be adjusted. After discussion, it was resolved that Mr. Sheldon's salary for the current fiscal year be set at 15% of the corporation's profits before taxes, as reported on its Federal tax return but before deducting Mr. Sheldon's salary, but that in no event it should be less than \$5,000.00 per month." [Tr. 722, 723]:

Mr. Bridges: May it be further stipulated that at a special meeting of the board of directors of said corporation, held May 9, 1956, with all of the five directors present, [425] that Mae Sheldon at that time resigned as a director and president of said corporation.

Mr. Enright: I will stipulate the minutes so recite. Whether they were present or not I do not know. That was May 9th. And on which date James G. Thompson was elected a director.

The Court: Is that so stipulated?

Mr. Bridges: Mr. Thompson was elected president and a director.

So stipulated.

May it be further stipulated that at the special meeting of the board of directors of the said corporation on March 5, 1956 a resolution was passed reading as follows:

“That Mrs. Mae Sheldon be and she hereby is appointed as president of this corporation, her compensation in said position being and hereby is fixed at the sum of \$3,500 per month commencing immediately.”

Mr. Enright: So stipulated. The persons present at that meeting were Robert Hohly and J. L. Merrifield.

The Court: So Stipulated?

Mr. Bridges: So stipulated.

(Testimony of Carroll Robert Hohly) [Tr. 821-826]:

Q. I believe you testified that you have been an accountant since sometime in 1948, is that correct?

A. That is correct.

Q. A certified public account since sometime in 1948?

A. Yes.

Q. For what period of time approximately have you been servicing in your professional capacity trailer manufacturing businesses?

A. A period of in excess of ten years.

Q. And approximately how many different trailer manufacturing businesses did you work for at that time in a professional capacity?

A. We have eight manufacturing clients.

Q. Is it true that during the last eight years you have performed professional accounting services for approximately that number of trailer manufacturing enterprises?

A. During the period we have performed services for 13.

Q. In connection with the performance of those accounting services, did you have occasion to learn the gross [556] sales, the net profits and the executive salaries paid by other trailer ventures in this area?

A. Yes.

Q. What kind of a criterion or standard is normally employed to determine the relative size or significance of a trailer business?

A. The units manufactured.

Q. Units manufactured in a unit time?

A. Yes.

Q. So many trailers per day? A. Yes.

Q. Or per month? A. Yes.

Q. Now employing that criterion, what was the relative size of Western Mobilehomes Distributors Corporation in the Southern California area in March of 1954 when Ben Sheldon first became financially interested in the enterprise? A. Very small.

Q. What was the relative size of the same corporation, based on the same criterion in the same market area, about the time that Ben Sheldon died?

A. It was the largest in the West Coast.

Q. Now from your own knowledge, can you tell us what services Ben Sheldon performed for the trailer business during the period from March 1954 to March 1956? [557]

A. Mr. Sheldon was the executive manager of the business, taking the full responsibility for direction of the enterprise, including its sales and purchasing policy.

Q. Do you have an opinion based upon your personal knowledge of the services that Ben Sheldon performed on behalf of the corporation B. H. Sheldon Co., based upon the responsibility assumed by Mr. Sheldon and upon the results achieved by him, and upon your knowledge of the practice in the trailer manufacturing trade in the Southern California area in compensating managerial personnel as to the reasonableness of the compensation paid Mr. Sheldon from February 1, 1955 until his death? A. I believe—

Q. Just answer yes or no. Do you have an opinion? A. Yes.

Q. What is that opinion?

Mr. Enright: To which objection is made as incompetent, irrelevant and immaterial. First, the partnership contract provided that the salary of the general partners was to be settled by the general partners and a majority of the interest of the limited partners; second, that salary of this corporation is of no materiality or relevancy at this time.

The Court: Salary as what?

Mr. Enright: Of Ben Sheldon as president—I [558] assume that is what he is referring to—as president of this corporation, that it is incompetent, irrelevant and immaterial.

Mr. Henigson: On plaintiff's theory of the case that might be true, but it is the Bank's theory that the enterprise was being operated as a corporation and not as a partnership during the period specified in my question, which was February 1, 1955 until the date of Ben Sheldon's death.

Mr. Enright: I missed the date February, 1, 1955. I withdraw my objection.

The Court: In its entirety?

Mr. Enright: I think that is advisable.

The Court: You may answer.

By Mr. Henigson:

Q. Will you please state your opinion as to the reasonableness of Mr. Sheldon's salary during the period specified?

Mr. Enright: Oh, no. The question is, what is a reasonable salary, not this question. Then I object to it. What is a reasonable salary in the opinion of this witness, I thought was the question.

Mr. Henigson: That is all I am asking for, the opinion of this witness.

The Court: In the form you put it, it is objectionable. The end result may be the same when the witness [559] answers, but let him answer his opinion as to what would be a reasonable salary for a person doing whatever this person was doing in that particular industry during that time.

By Mr. Henigson:

Q. What is your opinion based upon the factors earlier expressed to you as to what a reasonable salary would be for a man performing the services that you testified Ben Sheldon performed during the period indicated?

A. I believe that a reasonable salary to properly compensate an officer performing these duties would be based upon a minimum plus a percentage of the profits and that the results obtained, using the profit formula, would produce a reasonable salary.

Q. You are familiar with the results obtained during this period, are you not? A. I am.

Q. Will you give us a dollar amount based on those results, upon the responsibility assumed and the services performed?

A. I believe that a salary from \$70,000 to \$90,000 would be reasonable.

Q. Do you have an opinion as to a fair and reasonable salary figure for the services performed by Ben Sheldon on behalf of the partnership B. H. Sheldon Co. from July 1, 1954 to January 31, 1955, based upon your knowledge of what [560] Mr. Sheldon did, of the responsibility he had, and the results he achieved, and based upon your knowledge of the practice in the trailer manufacturing industry in the Southern California area in compensating executive or managerial personnel. Do you have an opinion? A. Yes.

Mr. Enright: As to how much he is paid?

Mr. Henigson: I haven't asked the question.

Mr. Enright: He asked whether he had an opinion. I submit his opinion is incompetent, irrelevant and immaterial, that was there was a written contract here specifically providing that salary was to be fixed by agreement of the parties.

The Court: That is plaintiff's theory of the case. The defendants' theory is different, I take it.

Mr. Enright: Plaintiff's theory of the case is that it is a matter of law by contract. There can be no salary until such time as they approve an agreement for a salary of some amount.

The Court: It is relevant under defendant's theory. Overruled.

I am not ruling of the sufficiency of the document on which you rely to preclude the issue.

The Witness: I believe that a salary from \$3,000 to \$35,000 would be reasonable. [561]

By Mr. Henigson:

Q. For that seven-month period, July 1, 1954 to January 31, 1955? A. Yes.

Mr. Henigson: No further questions, your Honor.

APPENDIX 9.

Finding 36 [Tr. 216]

* * * Robert Hohly did not exercise the degree of care an ordinary certified public accountant would have exercised in the area where his services were rendered during the period about July 9, 1954, to about February 1957, when rendering such services including the rendition of services pertaining to * * *(f) failing to inform plaintiff and the other limited partners he, along with B. H. Sheldon and J. L. Merrifield had, during the period about June 22, 1955, to March 13, 1956, acted as the directors of the corporation and has as such directors voted * * * (3) authorizing the corporation to engage in oil ventures, including the acquisition of leases from B. H. Sheldon resulting in losses of \$78,571.88 during the period about May, 1955, to March 1956. Robert Hohly did, as a certified public accountant, cause the books and records of the trailer venture, then being operated in the corporate name B. H. Sheldon Co., to record the transactions authorized by these resolutions.

Finding 39 [Tr. 218]:

Concerning defendants' pre-trial order statement of their contentions, the court finds:

* * * * *

(6) It is untrue plaintiff had knowledge of or consented to the trailer manufacturing venture or Flamingo expending money for drilling for oil; on the contrary, plaintiff was solicited by B. H. Sheldon and Mae Sheldon to invest with the Sheldons and others in certain oil ventures which were and would be separate from the trailer venture. That in reliance upon these solicitations, plaintiff did pay \$20,000.00 to B. H. Shel-

don in the year 1955 to be invested to acquire certain oil leases and to drill wells upon the leases. Thereafter, plaintiff was advised by B. H. Sheldon and Mae Sheldon some of the wells drilled resulted in dry holes. Thereafter, and after the death of B. H. Sheldon and after the plaintiff had incurred the expense of his attorneys and accountant, he acquired knowledge that Flamingo bore losses in the sum of \$78,571.88 [Ex. 207] arising out of these oil drilling investments, all as set forth in Finding 36(f)(3).

Supplemental Finding after Remand 1(d) [p. 5, lines 2-10 Supplemental Transcript of Record on Appeal after Remand]:

“(d) Even after giving the Sheldons credit for \$600 per month salary for the period February 1, 1955 to March 3, 1956, the Sheldons obtained in excess of \$170,000 in benefits from the partnership and corporation to which they had no equitable right. Plaintiff was damaged thereby to the extent of his 9% interest, or \$15,300, in addition to any other damages caused by the Sheldons’ fraud herein found.”

Supplemental Finding after Remand 12 [pp. 8, 9 and 10 Supplemental Transcript of Record on Appeal after Remand]:

“12. The Sheldons obtained various secret benefits from B. H. Sheldon’s control of the partnership and later the Corporation, all of which were concealed from plaintiff, a limited partner. Among such benefits were \$80,352.42 in profit-sharing salaries, \$14,814 unaccounted for expenses, the \$11,161.33 profit on the G. S. A. Contract, the shifting of \$78,571.88 oil losses incurred by B. H. Sheldon and recorded upon the

trailer venture's records, the deficiency between the Sheldons' capital-contribution obligation and their actual investment. After adjustments for known benefits have been made to reflect the Sheldons' 60% interest, and after credit has been given for a reasonable salary to B. H. Sheldon, the Sheldons' minimum unauthorized benefits and advantages, as to which the Sheldons were unjustly enriched, were the sum of not less than \$170,000; to plaintiff's damage to the extent of 9%, or \$15,300 on the 'benefits obtained' theory, in addition to plaintiff's damages for conversion of the securities.

Defendant Mae Sheldon's constructive fraud, and defendant Robert Hohly's constructive fraud and negligence, heretofore found, was a direct and proximate cause of the detriment suffered by plaintiff as a result of the Sheldons' misappropriation of his 9% partnership interest and the substitution therefor of a 4.29% minority stockholder's interest. Plaintiff's detriment is the difference between the value of his partnership interest at the time of such misappropriation, and the sale price received by plaintiff for the securities issued to him, to wit, \$23,083.35. One practical way to appraise the value of plaintiff's 9% partnership interest is to capitalize the earnings of the trailer venture over some reasonable period. (*Elsbach v. Mulligan*, 54 Cal. App. 2d 354, 136 P. 2d 651.) Plaintiff's 9% of the venture's actual profits of \$1,251,953.26 (R. 224) for 32 months, heretofore found, is \$112,675.79. Capitalizing such profits for 3 years, the value of plaintiff's misappropriated interest was \$126,760.27."

APPENDIX 10.

(Testimony of Donald R. Villee) [Tr. 579]:

By Mr. Henigson:

In connection with those minutes and directing your attention to what you have entitled here, unauthorized ventures, oil exploration, intangible drilling and investment expense, loss total \$78,571.88, still on Plaintiff's 207 for identification, what led you to conclude that those ventures were unauthorized?

A. The partnership agreement, Mr. Henigson.

Q. Did you inspect the minutes of the corporation, the minute book of the corporation of B. H. Sheldon Co.?

A. Yes, I did.

Q. Did you find any authority for those expenditures in that minute book?

A. I believe there were minutes dated September 1st of 1955 which related to the oil ventures, yes.

Q. So that you concluded that these expenditures [206] totaling \$78,000-odd were unauthorized by the corporation on account of a partnership agreement, is that correct?

Mr. Enright: Objected to on the grounds it calls for a conclusion of the witness.

Mr. Henigson: I am asking for the conclusion of the witness.

The Court: Overruled. He may answer.

Is that your reason?

The Witness: That is correct, your Honor.

The Court: What do you mean by intangible drilling and well expense?

The Witness: That was the terminology in the records, your Honor.

The Court: What do you interpret that to mean, space development?

The Witness: No, that would be drilling costs of an oil well principally.

The Court: Was there an identified oil well that it was spent on?

The Witness: There were many oil wells throughout the record that I examined.

By Mr. Henigson:

Q. You are talking about the corporate records?

A. Some in the corporate records, some in Mr. Sheldon's records. [207]

Q. I think the Judge's question referred to corporate records, if I am not mistaken.

The Court: I am referring to the corporate records, I don't suppose the witness thinks Mr. Sheldon's records have anything to do with this, does he?

The Witness: Mr. Sheldon received \$2,500 for an interest in a well from the B. H. Sheldon Co. Corporation.

The Court: But do the books of the corporation call this intangible drilling and development expense account?

The Witness: I believe that is the title of the account, your Honor.

The Court: What does intangible drilling mean in that connection?

The Witness: Intangible as opposed to machinery or other tangible costs in connection with a well. Intangible would be the cost of going down into the ground to locate the oil.

The Court: It was drilling expenses?

The Witness: Yes.

The Court: What it means then, intangible drilling and development expense means drilling and improvement of an oil well, is that it?

The Witness: Yes, your Honor.

The Court: One or more of them.

The Witness: Yes. [208]

Excerpt from Exhibit 169 [Tr. 1014, 1017]:

* * * * *

Minutes of Board of Directors
of
B. H. Sheldon Co.

Held on September 1, 1955

Present were Mr. Merrifield, Mr. Sheldon and Mr. Hohly, constituting all of the directors of the corporation.

Mr. Sheldon called the meeting to order and noted that the Board of Directors had no Secretary. Thereupon, Mr. Merrifield recommended that Mr. Hohly take notes of the transactions at the meeting and prepare the minutes. Thereupon, it was resolved that Mr. Hohly be appointed Secretary of the Board of Directors.

Mr. Sheldon called the Board's attention to some recent events:

* * * * *

Fifth, the President also mentioned that the corporation had acquired certain interests in oil leases and that it was in the corporation's best interest to acquire several others. After discussion, it was resolved that the action of the officers in these and in the management of the corporate business be approved by the

Board and that the officers be commended for the splendid progress the corporation is making.

See also pages 382 and 383 of Transcript where this resolution is read into the record.

* * * * *

(Testimony of Carroll Robert Hohly.) [Tr. 653]:

Q. (By Mr. Backer): Then, as I understand your testimony, you merely recorded the transactions as they appeared on the books of the organization?

A. That is correct.

Q. Now, concerning this transfer of the oil interests, what were you asked to do about that, Mr. Hohly, and who asked you to do it? [302]

A. The officers of the corporation had started in oil ventures. It was discussed at the Board of Directors meeting, and the question was brought up, "Is this in the corporate benefit?" And after discussion it was determined it was in the corporate benefit to go into the oil ventures, or, let us say, to continue.

Q. At the time that transfer was made by you on the books of the corporation, did you know the condition of the several oil wells?

A. At the transfer—I don't understand you. There was no transfer that I know of. This is the—

The Court: You testified, as I understand it, that there wasn't any transfer, that the corporation just picked up where someone left off, and started financing the development of these wells; is that correct?

The Witness: That is right.

Q. (By Mr. Backer): They took over the wells?

A. No, they started drilling wells.

The Court: Were any leases transferred to the corporation?

The Witness: They were acquired, purchased.

The Court: Well, they were transferred to the corporation by someone?

The Witness: Well, they were sold by someone, yes; sold and exchanged for a check. [303]

The Court: And it was on these properties covered by these leases that these monies you are testifying about were expended?

The Witness: Yes, sir.

Q. (By Mr. Backer): At that time, when they were recorded on the books—

A. The minute book, you mean?

Q. Yes.—did you know whether or not those wells would be productive? A. No, sir.

Q. Then, in other words, so far as you knew it, was a speculative venture? A. Yes, sir.

Q. Who instructed you to record those on the minutes?

A. Pardon?

Q. Who instructed you with regard to the oil transfers and the acquisition of them?

A. There were no instructions, counselor. The oil ventures were the result of the expenditure of cash, the writing of checks, and the record of the cash disbursements in the corporate records.

(Testimony of Earl L. Bailey.) [Tr. 767]:

A. Oh, it was probably the second week of February, as well as I can recall, 1956.

Q. And the second meeting?

A. That was in the offices of Hill, Farrer & Burrell at a Directors' meeting.

Q. About what date?

A. I don't recall the date of that meeting.

Q. Was that after or before the death of Ben Sheldon?

A. That was after Mr. Sheldon's death.

Q. So you had only the one meeting prior to Mr. Sheldon's decease,—

A. Yes.

Q. —with Walter A. Lutz and his wife?

A. Yes. [485]

Q. And where did that meeting occur?

A. In the office of the manufacturing plant there in Gardena.

Q. Now, in whose presence and under what circumstances did that meeting occur?

A. Well, Mr. Sheldon brought Dr. Lutz into my office, and introduced him to me, and then Dr. Lutz introduced Mrs. Lutz to me.

Q. So that the three of you—I am sorry—the four of you were present in that office, and there were no other persons present; is that correct? A. Yes.

Q. And what, if anything, did Ben Sheldon say to you at that time?

A. He told me who Dr. and Mrs. Lutz were, that they were shareholders in the corporation, and told me to give them any information they needed, or wished.

Q. And after that what did Mr. Sheldon do?

A. He left the office. He left my office.

Q. Leaving Dr. and Mrs. Lutz with you—

A. Yes.

Q. —in your office? A. Yes.

Q. And what happened next?

A. As I recall, Dr. Lutz told me that Mrs. Lutz [486] handled the detailed affairs of their business, and referred me to her as far as answering questions was concerned. Then Dr. Lutz left the office.

Q. Dr. Lutz left the office?

A. Yes, and Mrs. Lutz and I continued to discuss her questions.

Q. And for approximately what period of time was Mrs. Lutz with you alone in your office?

A. I would say about twenty minutes.

Q. And during that period of time Mrs. Lutz made inquiries of you? A. Yes.

Q. And you answered those inquiries, to the best of your ability?

A. To the best of my ability, yes, sir.

Q. What was the subject or subjects of her inquiries made to you during that twenty-minute period that she was with you in the office?

A. It was regarding their oil investments in—or, Mr. Sheldon and also the corporation—that is, the oil investments that the corporation had.

Q. Did you give Mrs. Lutz all the information you had about which she inquired?

A. Yes, all that I had available.

Q. Now, please relate, if you can, how that meeting [487] came to a close.

A. Mrs. Lutz, after we had perused our—the subject we were talking about, Mrs. Lutz got up and left the office.

Q. Was Mrs. Sheldon at any time during the course of this meeting or at its close present in your office?

A. Who?

Q. Mrs. Sheldon.

A. Mrs. Sheldon? No.

Q. You are quite sure of that?

A. Yes.

(Testimony of Earl L. Bailey.) [Tr. 779]:

Q. Now, you had been instructed by Ben Sheldon

to set up a set of books pertaining to oil operations some time after your employment?

A. No, that—those records were set up prior to my employment. I just continued them.

Q. Did you keep a set of records for oil investments of Ben Sheldon, individually?

A. Yes.

Q. And you kept a set of records for oil investments of the corporation?

A. As a part of the corporation accounts.

Q. They were two separate sets of records, were they?

A. Yes, they were.

Q. You were employed by the corporation, were you?

A. Yes.

Q. Did Ben Sheldon pay you personally to keep records for him?

A. As I recall, he paid ten or twenty dollars a month, [501] and I forget what it was, to keep his personal records. It was a very nominal amount.

Q. Weren't you in the process of setting up Ben Sheldon's books pertaining to oil investments at the time you were interviewed by Mrs. Lutz and Dr. Lutz?

A. Those books had been previously set up.

Q. I am referring to Ben Sheldon.

A. Ben Sheldon, yes. All of them; both sets of books.

Mr. Enright: Have we Ben Sheldon's books here, that the witness is referring to, setting up the oil investment?

Mr. Stutsman: I don't know.

Mr. Henigson: We have some books here, which you are invited to inspect.

(Thereupon a book was handed to counsel.)

TOPICAL INDEX

| | PAGE |
|--|-----------|
| Statement showing jurisdiction and summarizing prior proceedings | 1 |
| Summary statement of the case..... | 5 |
| Specification of errors..... | 10 |
| Summary of argument | 11 |
| Argument | 12 |
| I. | |
| The District Court erred in reasserting the correctness of its original judgment by reinstating it in derogation of the law of the case as embodied in the decision of this court.... | 12 |
| II. | |
| The District Court erred in imposing a capital contribution obligation upon Sheldon different from that defined by the partnership agreement | 15 |
| III. | |
| The District Court erred in disallowing Sheldon a credit for the \$57,200.00 advanced by him to the trailer business after the formation of the partnership and prior to its incorporation | 19 |
| IV. | |
| The District Court erred in disallowing Sheldon a credit in payment for personal services of the reasonable value of \$20,000.00 rendered by Sheldon to the trailer business after the formation of the partnership and prior to its incorporation | 20 |
| V. | |
| The District Court erred in awarding the sum of \$31,566.25 or any sum at all in excess of \$18,094.40 as conversion damages | 27 |
| Conclusion | 28 |
| Appendix 1. Exhibits | App. p. 1 |

TABLE OF AUTHORITIES CITED

| CASES | PAGE |
|--|----------|
| Averitt v. Garrigue, 77 Cal. App. 2d 170, 174 P. 2d 871..... | 17 |
| Criscuolo v. United States, 250 F. 2d 388..... | 13 |
| Dillon v. Sumner, 153 Cal. App. 2d 639, 315 P. 2d 84..... | 18 |
| Gaines, Estate of, 15 Cal. 2d 255, 100 P. 2d 1055..... | 17 |
| General Motors Accept. Corp. v. Mid-West Chevrolet Corp., 74 F. 2d 386..... | 14 |
| Hale v. Bohannon, 38 Cal. 2d 458, 241 P. 2d 4..... | 17 |
| Jones v. Polloch, 34 Cal. 2d 863, 215 P. 2d 733..... | 16 |
| Kaku Nagano v. Brownell, 212 F. 2d 262..... | 13 |
| Katz v. Haskell, 196 Cal. App. 2d 144, 16 Cal. Rptr. 453..... | 21 |
| McCollum, Estate of, 59 Cal. App. 2d 744, 144 P. 2d 176..... | 24 |
| Security First National Bank of Los Angeles v. Walter A. Lutz, 297 F. 2d 159..... | 2, 3, 12 |
| State of Kansas v. Occidental Life Ins. Co., 95 F. 2d 935..... | 13 |
| Tidlund v. Seven Up Bottling Co., 154 Cal. App. 2d 663, 316 P. 2d 656..... | 24 |
| United States v. Swift & Co., 270 U. S. 124..... | 26 |
| Wilson v. Wilson, 96 Cal. App. 2d 589, 216 P. 2d 104..... | 26 |
| Wirz v. Wirz, 96 Cal. App. 2d 171, 214 P. 2d 839..... | 24 |
| Young v. Nelson, 121 Wash. 285, 209 Pac. 515..... | 26 |
| STATUTES | |
| United States Code, Title 28, Sec. 1291..... | 5 |
| United States Code, Title 28, Sec. 1332..... | 1 |

No. 18174

IN THE

United States Court of Appeals

FOR THE NINTH CIRCUIT

SECURITY FIRST NATIONAL BANK, as executor of the Will of Ben
H. Sheldon, deceased, ROBERT HOHLY and MAE SHELDON,

Appellants,

vs.

EVA S. LUTZ, as Administratrix of the Estate of Walter A. Lutz, de-
ceased,

Appellee.

EVA S. LUTZ, as Administratrix of the Estate of Walter A. Lutz,

Appellant,

vs.

SECURITY FIRST NATIONAL BANK, as executor of the Will of Ben
H. Sheldon, deceased, ROBERT HOHLY and MAE SHELDON,

Appellees.

APPELLANT EXECUTOR'S OPENING BRIEF.

Statement Showing Jurisdiction and Summarizing Prior Proceedings.

This is the second appeal in an action tried to the court without a jury in which jurisdiction is founded upon diversity of citizenship and an amount in controversy exceeding the sum of \$10,000.00, exclusive of interest and costs. 28 U. S. C. §1332. Plaintiff is a citizen of the State of Washington¹ [R.* 154-155] and

¹Plaintiff Walter A. Lutz (herein called "Lutz") has died and his wife, Eva S. ("Sunny") Lutz, substituted as the duly appointed, qualified and acting administratrix of his estate.

*"R." and "R. Supp." are used herein to designate, respectively, the printed Transcript of Record and printed Supplemental Transcript of Record comprising the record in the first appeal (No. 16905 on the records of this court). "Clk. Tr." and "R. Tr." are used herein to designate, respectively, the Clerk's Trans-

defendants are, for diversity purposes, citizens of the State of California.²

On the first appeal, this court reversed the judgment of the district court rendered against all five defendants in the sum of \$31,566.25, set aside the \$15,000.00 exemplary damages assessed against Hohly and the \$15,000.00 “compensatory damages” assessed against Mae Sheldon, set aside the judgments against the other two defendants directing entry of judgment in their favor³ and remanded the cause for “further proceedings in conformity with this [court’s] opinion.” [Clk. Tr. 580.] *Security First National Bank of Los Angeles v. Walter A. Lutz*, 297 F. 2d 159, 166 (9th Cir. 1961).

That reversal was predicated in part upon the district court’s error of law in depriving Sheldon of credit for moneys owing him at the time of the incorporation of the business venture, a partnership in which Lutz was a limited partner. The indebtedness then owing Sheldon was for cash advances made by him to the partnership

cript of Record and the Reporter’s Transcript of Proceedings after remand. The numbers following such designations indicate pages in those records and, except where otherwise noted, reference to “R. Tr.” is to the Reporter’s Transcript of Proceedings had on March 19, 1962.

²Security First National Bank (herein called the “Bank”) is a national banking association organized under the laws of the United States and having its principal place of business in the State of California. The Bank is sued in its representative capacity as executor of the Will of Ben H. Sheldon, deceased (herein called “Sheldon”). The two other defendants, Mae Sheldon and Robert Hohly, are sued in their proprietary capacities.

³These two defendants, Flamingo Trailer Manufacturing Corporation (the corporate entity that received the partnership assets as of February 1, 1955) and James G. Thompson (who purchased all the corporate shares and debentures after Sheldon’s death) recovered judgment in their favor after remand pursuant to the instructions given by this court to the district court. [Clk. Tr. 582-583.]

and for services he rendered as its chief executive officer from the effective date of its formation, July 1, 1954, until its incorporation on February 1, 1955. The admitted facts established the net amount of Sheldon's additional cash contributions during this period, designated as loans on the cash receipts ledger of the partnership, to be \$57,200.00. [R. 158-159.] The uncontroverted evidence showed that Sheldon was paid no compensation at all for his services prior to February 1, 1955. [R. 1110.]

Sheldon unilaterally settled the obligations owing him by taking 80% of the corporate stock and debentures whereas he had (together with Mae Sheldon) but a 60% interest in the partnership. The Bank conceded that Sheldon was not entitled to settle the obligations owing him in this manner. The Bank contended in the district court and on the first appeal that Sheldon was, nevertheless, entitled to a credit for the partnership indebtedness owing him. In that contention this court found merit. *Security First National Bank of Los Angeles v. Walter A. Lutz, supra*, 297 F. 2d at 162.

The district court had denied any credit to Sheldon for his cash advances made after July 1, 1954 because it concluded that the \$57,200.00 was paid by Sheldon in fulfillment of obligations arising out of a promise he made to plaintiff in May, 1954, almost five months prior to the execution on October 18 of the integrated partnership agreement. [R. 218-219; 222-223.] The district court had further denied any compensation to Sheldon for his personal services because it concluded that under the terms of the partnership agreement the general partners were not entitled to compensation for their services absent the subsequent agreement of a

majority in interest of the limited partners. [R. 220-221.]

This court, in reversing the judgment of the district court on the first appeal, necessarily found, first, that the integrated partnership agreement made October 18, 1954 could not be altered or amended by promises or misrepresentations purportedly made some five months prior to its execution and, second, that Sheldon was entitled to *reasonable* compensation for the services he rendered, despite the fact the evidence showed there was no *agreed* amount of compensation.

After remand a hearing was had on February 19, 1962. At that time the "further proceedings" were limited by the court, with the consent of all counsel, to the taking of additional evidence on the issue of the reasonable value of Sheldon's services. [R. Tr. for February 19, 1962; 56-57.] Such evidence was adduced at a hearing had on March 19, 1962. It consisted in part of the testimony of two independent experts, both called on behalf of defendants. The first, James L. Harner,⁴ testified that for the period from July 1, 1954 to January 31, 1955, the reasonable value of the services rendered by Sheldon to the partnership was \$22,000.00, and for the period from February 1, 1955 until his death on March 3, 1956, \$71,000.00. [R. Tr. 73, 74.] The second expert, Page E. Golsan,⁵

⁴Mr. Harner is the sole consultant in industrial relations specializing in the field of executive compensation on the Western Region staff of the management services department of Arthur Young & Co., a national accounting firm. [R. Tr. 65-67.]

⁵Mr. Golsan is a consulting management engineer with twenty six years' experience with Ford, Bacon & Davis, a national management engineering firm, the last ten of which were as its senior partner in charge of its Pacific Coast business. [R. Tr. 79-82.]

testified that in his view the reasonable value of those services for the periods in question was \$20,000.00 and \$77,000.00, respectively. [R. Tr. 84, 88.]

The district court thereafter reaffirmed its original findings of fact,⁶ made supplemental findings of fact hopelessly at variance with the evidence and with the opinion of this court and reinstated the same judgment against the Bank as executor, increasing the amount of the judgment against each of the other two defendants.

Timely notices of appeal were filed by all three defendants from the final judgment of the district court and their respective appeals duly perfected. Jurisdiction of this court is founded on 28 U. S. C. §1291.

Summary Statement of the Case.⁷

In early 1954, Sheldon, a retired contractor 65 years old, became interested, first, as landlord to, and then as an investor in and officer of a going trailer manufacturing business. [R. 155; R. Tr. 15-16, 20-22.] In May, 1954, having bid for and been awarded a government contract to manufacture 169 house trailers, Sheldon invited others, including Lutz and a lawyer

⁶The obduracy of the district court in resurrecting the identical judgment reversed by this court and in reaffirming the findings reviewed by this court and found wanting is best exemplified by the district court's reaffirmation of Finding of Fact 39(9), *viz.*, that James G. Thompson was *not* a bona fide purchaser of the stock and debentures purchased by him from the Bank as executor—a finding utterly inconsistent with the decision of this court on the first appeal and its direction to the district court to render a judgment in favor of James G. Thompson and utterly inconsistent with the judgment rendered after remand by the district court pursuant to that instruction.

⁷A lengthy statement of the case, fully documented by reference to the printed record on appeal, appears at pages 5-31 of the Bank's Opening Brief in the first appeal.

named Eisenhower, to participate as investors in the venture. [R. 156, 863-64, 1052.] On May 24, Lutz responded to Sheldon's invitation and agreed to purchase three points in the venture for \$18,000.00 [R. 944.] On May 28, Eisenhower, who had lent Sheldon some assistance with the federal agency responsible for awarding the government contract, agreed to purchase a 5% interest for \$10,000.00 [R. 865-66; R. Supp. 10-11.] The same day Sheldon wrote Lutz that Eisenhower was "taking five points" in the venture. [R. 945-46.]

On June 2, Eisenhower made his cash investment of \$10,000.00 and on June 22, Lutz paid the \$18,000.00 for the three point interest in the venture for which he had bargained. [R. 865; R. 156.]

In early July, 1954, Eisenhower and Sheldon met in Los Angeles to work out a partnership agreement that would be effective retroactively as of July 1. [R. 867-71; R. Supp. 14-19.] One of the topics discussed was the capital contributions and percentage participations of each of the investors. Sheldon had allocated a 3% interest to Lutz for his \$18,000.00 cash investment [R. Supp. 20, 72], a 5% interest to Eisenhower purchased for \$10,000.00 cash and "contributions through services and loans" [R. 865-66, 924], and 60% to himself to cover his total investment. [R. Supp. 17-18.]

Sheldon's cost investment as of July 1, 1954 was \$81,655.97.⁸ The limited partners had contributed cash in

⁸As of July 1, 1954, Sheldon had contributed to the partnership land, a factory building, cash and all the assets subject to liabilities of the going business. [R. 1106, 716-717.] Sheldon had paid a

the aggregate amount of \$56,020.00 [R. 58-59.] Thus, Sheldon's cost investment constituted 59.3% of the total cash investment for which he was to receive a 60% interest. Eisenhower, on the other hand, had contributed 7.3% and Lutz 13.2% of the total cash investment for which they were to receive but 5% and 3%, respectively, of the partnership shares.

Both Sheldon and Eisenhower thought the proposed percentage allocations unfair. They tried several other divisions of the forty points allocated to the limited partners [R. Supp. 20-21], finally increasing Lutz' interest from 3% to 8% and Eisenhower's from 5% to 13% (split 10% to himself and 3% to his wife Lucille). [R. 1115; R. Supp. 72-3, 81.]

total of \$10,300.00 to acquire control of the going business in April. [R. 155. The printed record at page 1106 reflects two payments, one of \$6,000.00 and one of \$4,000.00 by Sheldon to purchase the controlling stock interest in the going business. The \$6,000.00 figure is correct but the \$4,000.00 figure should be \$4,300.00 as shown by the admitted facts in the amended pre-trial conference order as reproduced at page 155 of the printed record.] His total net cash contribution aggregated \$22,000.00 after allocation of \$6,000.00 to the capital accounts of one of his children and a child of Mae Sheldon by a former marriage. [R. 1106, 716-717.] Of the \$22,000.00 net cash contribution, \$8,000.00 had its source in a personal loan to Sheldon from one L. B. McKinney. [This amount is not reflected in the summary prepared by plaintiff's expert accountant, Mr. Villee, and reproduced at R. 1106. Mr. Villee, however, conceded that the \$8,000.00 amount designated on the cash receipts ledger of the business as "Loan, McKinney-Sheldon" was posted to notes payable in favor of Sheldon and that the posting to the credit of Sheldon appeared regular on its face. He further conceded that he would require additional evidence before concluding that the posting to the credit of Sheldon was not correct and that he found no such additional evidence. See R. 535-538.] The cost of the land and of the factory building contributed by Sheldon was, respectively, \$14,250.00 and \$35,105.97. [R. 1106.] Thus, the aggregate cost investment by Sheldon as of July 1, 1954 was \$49,355.97 for land and factory building, \$10,300.00 to acquire control of the going business contributed to the partnership and \$22,000.00 cash, for an aggregate of \$81,655.97.

In mid-August, Sheldon, on his own initiative, asked Eisenhower if he and Lucille would decrease their total percentage interest so that Lutz' interest could be correspondingly increased. [R. Supp. 48-49, 81-82.] Eisenhower agreed to a 1% decrease in the interest allocated to Lucille and Lutz' interest was again increased, this time from 8% to 9%. As so modified, the partnership agreement, finally reduced to writing, was executed by all the partners on about October 18, 1954. [R. 156.]

During the period from and after the effective date of formation of the partnership and prior to its incorporation, Sheldon advanced cash to the partnership in the net sum of \$57,200.00 as follows: \$5,200.00 in July, \$10,000.00 in October, \$16,000.00 in December and \$26,000.00 in January, 1955.⁹ [R. 158-59, 1106.]

During the period from March, 1954 until his death in 1956, Sheldon was "in charge of business operations" [R. Tr. 9-10], was chief executive officer of the trailer enterprise [R. Tr. 22, 24] to whom the production manager, McKinney, reported [R. Tr. 24], was alone engaged in the sales work which thrust the business into prominence within a year [R. Tr. 22], participated in design of the trailers being manufactured [R. Tr. 24], was chief financial officer for the company [R. Tr. 25] and was, as the district judge himself succinctly noted, "the chief executive officer of everything. . . ." [R. Tr. 24.]

In compensation for his labors which in June, 1954, consumed six 12-hour days a week in the business [R.

⁹An additional \$10,000.00 advanced by Sheldon in July was repaid to him without interest in August, 1954. [R. 1106.]

946-47] and from August, 1955 until his death not less than five full days a week [R. 765], Sheldon received not a penny prior to incorporation on February 1, 1955. [R. 1110; R. Tr. 26-27; R. Tr. 52-53.] Thereafter he received \$4,776.07 as salary for the month of February, 1955 [R. 1110; R. Tr. 39-40] and \$72,076.35 for the twelve-month period ending February 29, 1956, or an aggregate of \$76,852.42 for the thirteen months following incorporation and until his death on March 3, 1956. [R. 1110.]

By the manner in which the February 1, 1955 incorporation of the business was accomplished, the Sheldon interest was increased from 60% to 80% while that of Lutz was decreased from 9% to 4.29%. [R. 158.]

Following Sheldon's death on March 3, 1956, the Bank was appointed and qualified as executor of Sheldon's will. [R. 160.] In April, 1956, the Bank as executor and Mae Sheldon entered into an agreement with James G. Thompson for sale of the Sheldon securities in the trailer corporation, comprising both shares and debentures. With approval of the probate court, the agreement was consummated on May 8, 1956 for a total purchase price of \$425,000.00, allocated \$44.04 per share and face value (without accrued interest) for the debentures. [R. 160; R. 1138-1145.]

In October, 1956, Lutz filed a creditor's claim against Sheldon's estate by which he claimed 390.98 shares and \$6,341.45 face value debentures of the trailer corporation. [R. 67-70.] The claim was rejected by the Bank as executor and this action thereafter commenced by Lutz—predicated upon the rejected claim—within the time prescribed by law.

On June 14, 1957, Lutz sold his shares and debentures in the trailer corporation for the sum of \$23,083.35, allocated \$44.04 per share and face value together with accrued interest, for the debentures. [R. 161.] This price plaintiff considered fair. [R. 454.]

Specification of Errors.

1. The district court erred in refusing to follow the plain mandate of this court in Cause No. 16905 by resurrecting, on evidence more favorable to the Bank, the identical judgment against it as was heretofore reversed.

2. The district court erred in imposing upon Sheldon a capital contribution obligation different from that defined by the written partnership agreement.

3. The district court erred in construing the compensation provisions of the written partnership agreement to require subsequent accord among a majority in interest of the limited partners as to amount of compensation as a condition precedent to any obligation owing Sheldon for salary.

4. The district court erred in receiving and relying upon evidence of antecedent negotiations and promises to vary or contradict the plain terms of the written partnership agreement.

5. Findings of fact 37, 38, 39 and supplemental findings of fact 1 to 16, both inclusive, are clearly erroneous in that they are unsupported by the evidence and are in derogation of the law of the case.

6. The district court erred in arbitrarily rejecting the uncontradicted and entirely probable opinion testimony of the independent and unimpeached experts who valued the services rendered by Sheldon.

7. The district court erred in disallowing Sheldon credit for his \$57,200.00 advances and the reasonable value of the services he rendered to the trailer venture.

8. The district court erred in awarding as conversion damages any sum in excess of \$18,094.40.

Summary of Argument.

I.

The district court erred in reasserting the correctness of its original judgment by reinstating it in derogation of the law of the case as embodied in the decision of this court.

II.

The district court erred in imposing a capital contribution obligation upon Sheldon different from that defined by the partnership agreement.

III.

The district court erred in disallowing Sheldon a credit for the \$57,200.00 advanced by him to the trailer business after the formation of the partnership and prior to its incorporation.

IV.

The district court erred in disallowing Sheldon a credit in payment for personal services of the reasonable value of \$20,000.00 rendered by Sheldon to the trailer business after the formation of the partnership and prior to its incorporation.

V.

The district court erred in awarding the sum of \$31,566.25 or any sum at all in excess of \$18,094.40 as conversion damages.

ARGUMENT.

I.

The District Court Erred in Reasserting the Correctness of Its Original Judgment by Reinstating It in Derogation of the Law of the Case as Embodied in the Decision of This Court.

On the first appeal, this court decided that Sheldon and the persons claiming through him were, in the computation of conversion damages, entitled to consideration for the \$57,200.00 cash advanced to and the reasonable value of Sheldon's services rendered on behalf of the trailer partnership. This court concluded that if Lutz, "upon equitable principles, is to be permitted to avoid the consequences of his consent to incorporation, equitable consideration must be given to the rights of Sheldon, restored to him in the eyes of equity by that very avoidance." The findings and judgment revealing that no such consideration was given, the cause was remanded for "due consideration to the balancing of equities." *Security First National Bank of Los Angeles v. Lutz, supra*, 297 F. 2d at 163.

Ignoring the plain mandate of this court, the district court determined on remand that "Sheldon has no equities to which he, or anyone claiming through him, is justly entitled under recognized equitable principles." [Clk. Tr. 601, lines 26-28.] It thereupon reinstated its original judgment as against the Bank, assessing larger amounts of damages against the other defendants.

Thus, this case stands now in precisely the same posture as it did on the first appeal but for the evidence adduced at the further proceedings following remand and but for the supplemental findings of the district

court which are, as hereinbelow particularized, clearly erroneous.

The evidence adduced at the further proceedings following remand comprises the testimony of six witnesses, three called by plaintiff and three by defendants [R. Tr. 3], and two exhibits, one detailing the total charges made by plaintiff's expert accountant [R. Tr. 33-35; Ex. 222] and the other a report of the inheritance tax appraiser of the State of California valuing the life estate bequeathed Mae Sheldon under the terms of Sheldon's will. [R. Tr. 100-103; Mae Sheldon's "E".] The witness' testimony was primarily directed to the question of the degree of responsibility, authority and devotion of Sheldon to the management of the trailer business, with a valuation by two defense experts of the services rendered by Sheldon. All the witnesses with personal knowledge of Sheldon's activities (two of whom were called by plaintiff), reinforced the defense contentions of his worth to the business enterprise and his responsibility for its success. [R. Tr. 9-10, 21-25.] That new testimony was merely cumulative to testimony adduced at the first trial.

Accordingly, the district court was bound by the law of the case to afford Sheldon, and those claiming through him, consideration for his advances and for the reasonable value of his services. *Criscuolo v. United States*, 250 F. 2d 388 (7th Cir. 1957); *Kaku Nagano v. Brownell*, 212 F. 2d 262, 263 (7th Cir. 1954); *State of Kansas v. Occidental Life Ins. Co.*, 95

F. 2d 935, 936 (10th Cir. 1938); *General Motors Accept. Corp. v. Mid-West Chevrolet Corp.*, 74 F. 2d 386, 388 (10th Cir. 1934).¹⁰ This the district court did not do.

Instead, it reaffirmed its original findings of fact 1 through 40 and 42 [Clk. Tr. 3, lines 29-30] supplementing those findings by further findings merely iterating its originally adopted positions, first, that the \$57,200.00 advances were capital contributions in fulfillment of a promise made by Sheldon almost five months prior to the reduction to writing and the execution of the partnership agreement and, second, that Sheldon was not entitled under the agreement to any compensation at all, its plain terms to the contrary notwithstanding. In so doing, the district court acted in disregard of the evidence before it and in derogation of its duty under the mandate of this court.

¹⁰"It is well settled that all matters decided on appeal become the law of the case to be followed in all subsequent proceedings in both the trial and appellate court. [Cites omitted.] That doctrine applies where the evidence is substantially the same on both trials. It does not have application if the evidence on the subsequent trial presents a materially different situation. [Cites omitted.] And the introduction of new testimony at the subsequent trial which is merely cumulative does not take a case without the rule. *Zurich General Accident & Liability Ins. Co. v. O'Keefe* (C.C.A.) 64 F. (2d) 768. Of course, the doctrine is not an iron rule which denies a court the power to correct a manifest error or mistake of a serious nature in a former decision. It is one of sound policy. *Litigation would be unduly prolonged if every dissatisfied suitor were permitted to obstinately renew on successive appeals questions previously considered and decided.*" (Emphasis added; 74 F. 2d 386, 388.)

II.

The District Court Erred in Imposing a Capital Contribution Obligation Upon Sheldon Different From That Defined by the Partnership Agreement.

The district court deprived Sheldon of any credit for the \$57,200.00 net cash he advanced to the partnership after the effective date of its formation, \$42,000.00 of which was contributed between December 26, 1954 and January 26, 1955. [R. 1106.] It did so because it found those cash payments, admittedly designated as loans on the cash receipts ledger of the partnership [R. 158-159], to be contributions to the partnership capital. That result obtains, says the district court, because the payments “were in partial satisfaction of the Sheldons’ capital contribution obligation. . . .” [Clk. Tr. 8, lines 12-13.] This capital contribution obligation, according to the district court’s theory, has its genesis in a representation made by Sheldon to Lutz about May 20, 1954 that Sheldon was going to invest \$150,000.00 in the business.¹¹ [R. 401-402; see also R. Tr. for February 19, 1962, 26-29.]

Paragraph 6 of the integrated partnership agreement, as finally executed on October 18, obligated the Shel-

¹¹Alternatively, the District Court suggests in its supplemental finding [Clk. Tr. 8, lines 21-23] that Mae Sheldon’s representation of June 22, 1954 that “we have over \$100,000.00 in . . .” the business [R. 947] has some bearing on Sheldon’s capital contribution obligation. That, of course, is a logical impossibility since Lutz had already agreed by his May 24, 1954 letter to purchase three points in the business for \$18,000.00 [R. 945]. Barring the question of his peculiar powers of extrasensory perception as to which the record is silent, Lutz could neither have anticipated nor relied upon Mae Sheldon’s June 22 representation in agreeing the preceding May to take a three per cent interest in the trailer business.

dons to contribute as their share of the partnership capital, not \$150,000.00 as the district court has determined, but rather a going trailer manufacturing business together with the land and factory buildings then being used in the conduct of that business. [R. 58-59.] This contribution the general partners admittedly made. [R. 156-157.] Concededly, the cost of that contribution to the general partners was not \$150,000.00. Presumably for that reason, the district court deemed the \$57,200.00 cash payments made by Sheldon to the partnership after the effective date of its formation to be additional capital contributions in partial fulfillment of Sheldon's May 20 promise. Were that construction of the written agreement permitted to stand, Sheldon's capital contribution to the partnership at his cost would aggregate \$81,655.97 (see note 8, *supra*) plus \$57,200.00, or \$138,855.97. Such a construction would devolve upon Sheldon the obligation to pay 71.3% of the total capital contributions for a 60% share of the business. The inherent unfairness of that result aside, the district court's refuge in a May 20 promise to construe the plain language of the October 18 agreement violates the parol evidence rule and ignores the aggrandizement of Lutz' partnership share from the time he first agreed to purchase three points in May until the execution of the October agreement which accorded him a nine per cent interest, all for the same \$18,000.00 investment.

The rules of construction require that courts give effect to the mutual intention of the parties as it existed at the time of the execution of their agreement and as that mutual intention is objectively manifested by the language used. *Jones v. Polloch*, 34 Cal. 2d 863, 866, 215 P. 2d 733. The words employed to manifest that

mutual intention are to be interpreted in the sense that they are ordinarily used. Only where upon the face of the agreement itself there is doubt or ambiguity as to the meaning intended should resort be made to extrinsic evidence disclosing the circumstances surrounding the execution of the agreement. *Averitt v. Garrigue*, 77 Cal. App. 2d 170, 172-173, 174 P. 2d 871. Contemporaneous and prior oral negotiations are regarded as merged into the writing and cannot vary or contradict the terms of the written agreement. *Hale v. Bohannon*, 38 Cal. 2d 458, 465, 241 P. 2d 4. This rule is not a rule of evidence but a rule of California substantive law. *Estate of Gaines*, 15 Cal. 2d 255, 264-265, 100 P. 2d 1055.

The capital contribution provisions of the integrated partnership agreement made October 18 are clear and unambiguous. They require no resort to extrinsic evidence to ascertain the intention of the parties. The words used mean precisely what they say, viz., that the "contribution of the general partners to the capital of this partnership shall consist of real property with the buildings situate thereon . . . together with all the machinery, equipment, tools, goods, wares and merchandise, inventory of material, work-in-process, cash and accounts receivable, and all assets . . . now used . . . in the manufacture, sale and distribution of house trailers." [R. 58-59.] No permissible construction of that language would either allow the imposition on Sheldon of an obligation to contribute \$150,000.00 as his capital share or tolerate the conversion of his \$57,200.00 advances into capital contributions.

"If this could be done then every written contract of sale, no matter how carefully and specifically

it described the property to be sold, could be varied by proof that the seller orally agreed to convey additional property not described in the written contract. A written agreement to sell a horse for \$100 could be varied by evidence that the seller had also orally agreed to transfer a cow, or [a] contract to purchase 1,000 tons of coal could be varied by showing an oral agreement to deliver a bonus of 100 tons additional for the same consideration.” *Dillon v. Sumner*, 153 Cal. App. 2d 639, 643, 315 P. 2d 84.

Thus, the district court erred in varying the plain meaning of the capital contribution provisions by reference to an oral promise made almost five months prior to execution of the integrated written agreement. And even assuming that resort to the circumstances surrounding execution of the integrated agreement were necessary to enable interpretation of its terms, still the district court’s refusal to take cognizance of the increase in Lutz’ partnership share is unexplained and inexplicable.

In May, 1954, Lutz had bargained for a three point interest in the business. In July, 1954, that interest was increased from three to eight per cent at the initiative of Eisenhower and Sheldon. In August, at Sheldon’s sole initiative, Lutz’ interest was again increased, this time to nine per cent. If Lutz were seeking to reform the partnership agreement to include a capital contribution on the part of Sheldon of \$150,000.00, *as the district court has done*, then Lutz’ interest must necessarily be revised to three per cent *in line with his original agreement*. This revision the district court failed to make. And Lutz is understandably reluctant

to urge this reformation since he received 4.29 per cent of the corporate shares and debentures. If, however, Lutz is to be permitted to reap the benefits of the October 18 agreement—the larger share afforded him *at Sheldon's instance*—then he ought to be compelled to abide by its clear and unambiguous terms and not upon a manifestly unreasonable interpretation of the capital contribution obligations affecting only the general partners.

III.

The District Court Erred in Disallowing Sheldon a Credit for the \$57,200.00 Advanced by Him to the Trailer Business After the Formation of the Partnership and Prior to Its Incorporation.

Paragraph 23 of the partnership agreement provides in part that if additional funds are needed to carry on the business operations of the partnership, the general partners are authorized to borrow such funds from any financial institution, from any one or more of the limited partners, or from the general partners themselves subject to the understanding that “any such loan made by any of the partners shall be repaid before any distribution of income or capital . . . to any of the partners.” [R. 66.]

From the effective date of its formation on July 1, 1954, the partnership did experience need for additional funds in the operation of its business. That need was satisfied by bank loans [R. 1159] and by advances made to the partnership by Sheldon himself. [R. 158-59.]

In July Sheldon advanced the sum of \$15,200.00 to the partnership, of which \$10,000.00 was repaid him in August. [R. 1106.] From October 13, 1954 to

January 26, 1955, Sheldon made five separate additional cash advances to the partnership in the aggregate sum of \$52,000.00. [R. 1106.] Each of those advances was designated on the cash receipts ledger of the partnership to be a loan. [R. 158-59.] The partnership thereby received the benefit of the use of Sheldon's money for which, under the terms of the district court judgment, Sheldon and those claiming through him received not a penny's credit.

Pursuant to the terms of the consent to incorporation signed by Lutz on January 31, Sheldon was entitled to take additional corporate securities to be issued by the receiving corporation in repayment of all or part of the partnership obligations owing him. This he did. That action was, however, deemed improper by the district court and by this court. Lutz was thereby permitted to avoid the consequences of his consent to incorporation. As of February 1, 1955, Sheldon was nevertheless entitled to repayment of the advances made. Disallowance by the district court of any credit for those advances constituted judicial error.

IV.

The District Court Erred in Disallowing Sheldon a Credit in Payment for Personal Services of the Reasonable Value of \$20,000.00 Rendered by Sheldon to the Trailer Business After the Formation of the Partnership and Prior to Its Incorporation.

The district court, to justify its refusal to grant a credit or offset to Sheldon and those claiming through him for the personal services Sheldon rendered and for which he was not paid, determined, first, that "Sheldon disclaimed and waived any right to salary" [Clk. Tr.

602, lines 4-5], second, that Sheldon's services were of *de minimis* value to the business [Clk. Tr. 602, lines 16-32 and 603, lines 1-5], third, that Sheldon actually paid himself \$4,776.07 for the period from March 18, 1954 to February 18, 1955 [Clk. Tr. 602, lines 6-15] and fourth, that his reasonable worth was \$600.00 monthly [Clk. Tr. 603, lines 6-10 and 604, line 1] which was considerably less than he actually received. Any relationship between those supplemental findings of the district court and the evidence before it borders upon coincidence.

First, there is no evidence that Sheldon disclaimed or waived any right to salary. To the contrary, that Sheldon took salary during the period following the February 1, 1955 incorporation and that he took additional corporate shares and debentures in repayment of the partnership salary obligation owing him manifested an intention on his part to be compensated for those services. That Sheldon indicated in the spring of 1954 that he had no interest in salary compensation cannot reasonably be construed to be a waiver of his right to salary where, under the terms of the October 18 partnership agreement, he was expressly afforded that right. So to construe Sheldon's antecedent comments is to read the compensation provisions of the integrated agreement entirely as surplusage—a result at war with recognized rules of construction. It is the office of the court, in the construction of an agreement, to explain and not to omit what has been inserted. *Katz v. Haskell*, 196 Cal. App. 2d 144, 157, 16 Cal. Rptr. 453.

Second, that Sheldon was primarily responsible for the growth of the business into the largest trailer manufacturer on the West Coast at the time of his death

[R. 822-823] is plainly evident from the record, the district court's supplemental finding that those services were "insubstantial" to the contrary notwithstanding. [Clk. Tr. 603, line 5.] The "experienced trailer executive," J. L. Merrifield, at whose door the district court laid some of the responsibility for the venture's success, was able prior to Sheldon's association with the business to sell a total of some fifteen trailers during the months of April, May, June and July of 1953. [R. 1045.] As of March 18, 1954, when Sheldon first assumed command, the book value of the venture's tangible assets over liabilities (exclusive of good will) was \$3,441.81. [R. 1047.] On February 29, 1956, less than two years later, the business had annual sales of over \$6,200,000.00 and a net worth of approximately \$324,000.00 of which almost \$292,000.00 was earned surplus. [R. 1134-35.] While it is true as the district court found that Eisenhower was instrumental in securing the May 19, 1954 government contract, there is no evidence that he "participated in production and sales policy decision." [Clk. Tr. 602, lines 24-7.] In so far as Eisenhower's procuring "vital raw materials" is concerned [Clk. Tr. 602, line 25], plaintiff's own witness, Merrifield, testified that Eisenhower's role in this regard was to inform "Mr. Sheldon where plywood could be bought from some mills that he had some interest in," that is, "he informed Mr. Sheldon where these mills were and put him in line where he could buy material there." [R. Tr. 18, lines 11-12 and 16-18.] The factory superintendent, L. B. McKinney, who was in charge of production, was hired by Sheldon and reported to Sheldon. [R. Tr. 24.] Sheldon alone was responsible for the sales effort upon which the business

success was based. [R. Tr. 22.] He was the chief executive officer [R. Tr. 22, 24] and the chief financial officer [R. Tr. 25] and even participated in the design of the trailers being manufactured. [R. Tr. 25.] As the district judge himself observed:

“ . . . that man Sheldon was the dynamo of the enterprise. I don't think there is any question about that. He ran every aspect of it, as I see it. He not only ran it, he was the dictator of it in every respect.” [R. Tr. 105, lines 1-4.]

Third, the uncontroverted evidence discloses that Sheldon received not a single penny for the services he rendered prior to February 1, 1955. [R. 1110.] That the district court could find to the contrary [see Clk. Tr. 602, *supra*] is incredible in that the subject was explicitly covered in the further proceedings following remand and it was the plaintiff's own expert, Mr. Villee, who testified unequivocally that the salary payment of \$4,776.07 debited on the books of the receiving corporation as of February 28, 1955 and found by the district court to cover the period from March 18, 1954 to February 18, 1955 was for officer salaries *for the single month of February, 1955!* [R. Tr. 39-41.]

Fourth, the \$600.00 determination of the district court as the reasonable monthly value of the services that Sheldon rendered is without *any* evidentiary support. The record reflects three valuations only, one by the defendant Hohly and two by independent experts called on behalf of the defendants. Their opinions are as follows:

Carroll Robert Hohly (defendant)

| | |
|----------------------------|-------------------|
| July 1, 1954-Jan. 31, 1955 | \$30,000-\$35,000 |
| Feb. 1, 1955-Mar. 3, 1956 | 70,000- 90,000 |

James L. Harner (independent expert — Arthur Young & Company)

July 1, 1954-Jan. 31, 1955 \$22,000

Feb. 1, 1955-Mar. 3, 1956 71,000

Page Golsan (independent expert—retired partner of Ford, Bacon & Davis)

July 1, 1954-Jan. 31, 1955 \$20,000

Feb. 1, 1955-Mar. 3, 1956 77,000

The district court was of course at liberty to reject the opinion of defendant Hohly because of his interest in the outcome of the action. *Tidlund v. Seven Up Bottling Co.*, 154 Cal. App. 2d 663, 666-67, 316 P. 2d 656. And plaintiff was at liberty to adduce other satisfactory evidence rebutting the opinion testimony of the independent and unimpeached experts offered on the part of the defendants. *Estate of McCollum*, 59 Cal. App. 2d 744, 750, 144 P. 2d 176. Such rebutting evidence was not, however, forthcoming. Under the circumstances, the district court was not entitled to reject arbitrarily or upon mere caprice the uncontradicted and entirely probable testimony of the unimpeached experts. *Wirz v. Wirz*, 96 Cal. App. 2d 171, 176, 214 P. 2d 839. Yet that is precisely what the court did, without justification or the semblance of an explanation. Further, the court made its supplemental finding of fact that the reasonable value of Sheldon's services was \$600.00 monthly, a finding not only without evidentiary support but one inherently improbable in the light of common experience. As the district judge had earlier opined:

“Well, of course, *a thousand dollars a month* wouldn't be any great pay for someone to run that business. I don't imagine there'd be people com-

petent to run it standing in line to make application for employment *at that rate.*" [Emphasis added; R. Tr. for February 19, 1962, 55, lines 19-23.]

The denial of credit for services rendered on the first appeal was founded upon the fact that the general partners and a majority in interest of the limited partners had never reached agreement upon the *amount* of compensation to which Sheldon was entitled [R. 220-221] and upon judicial interpretation of the compensation provisions of the partnership agreement that, absent such subsequent agreement as to amount, no compensation at all was payable to Sheldon. The finding, buttressed by a supplemental finding to the same effect [Clk. Tr. 601, lines 15-21], is correct; the interpretation, however, is against the law.

The partnership agreement includes a provision for compensation of the limited partners employed in the business "at such compensation as shall be determined by the General Partners . . ." [R. 65, par. 22] and a provision for the compensation of the general partners at "such reasonable compensation for services in operating the business of the partnership as shall be agreed upon between said General Partners, and a majority in interest of the Limited Partners . . ." [R. 65, par. 23.] The district court was quick to realize that construing the compensation provisions relative to the general partners as requiring the subsequent agreement of a majority in interest of the limited partners rendered those provisions nugatory. In this regard the district judge said:

"And what is all that? That is an agreement to make an agreement *which is worth nothing*, isn't it? [Emphasis added; R. Tr. for February 19, 1962, 31, lines 7-9.]

Nevertheless, the court adopted that construction which rendered the words used meaningless. As we said on the first appeal, that result is patently absurd. Sheldon could not unilaterally deprive Merrifield, one of the limited partners employed in the business, of any and all compensation by refusing to agree upon the amount of his salary compensation. Neither can a majority in interest of the limited partners deprive Sheldon of salary compensation by arbitrarily withholding their consent.

Manifestly, where a provision for the benefit of a particular person is included as an inducement to his execution of the contract, there must be some method by which that person can enforce the contract provision though the agreement of the other signatories is required by its terms and is withheld. That method is determination by the court. *United States v. Swift & Co.*, 270 U. S. 124, 140; *Young v. Nelson*, 121 Wash. 285, 209 Pac. 515; *Wilson v. Wilson*, 96 Cal. App. 2d 589, 216 P. 2d 104.

Manifestly, where a partnership agreement contemplates compensation by its express terms, that compensation should not be denied simply because the subsequent agreement as to amount either was withheld or was not solicited. Concededly, Sheldon had no right to fix his compensation arbitrarily. Had he appropriated \$50,000 as compensation for services the reasonable value of which was but \$20,000, he would be answerable to the partnership for the unjustified portion of the salary taken. The only proper measure of the salary compensation owing, absent a subsequent agreement as to its amount, is *the reasonable value of the services rendered*.

Of the obligations owing Sheldon at the time of the incorporation of the business there was \$20,000.00 in salary (taking the lower of the two expert valuations) in addition to the \$57,200.00 advances he had made. For this, Sheldon was entitled to credit. The district court's disallowance of that credit constituted judicial error.

V.

The District Court Erred in Awarding the Sum of \$31,566.25 or Any Sum at All in Excess of \$18,094.40 as Conversion Damages.

The Bank, acting in its representative capacity, sold to James G. Thompson on May 8, 1956, all of the trailer venture securities standing in Sheldon's name. It thereby realized \$44.04 per share of stock and face value, without any accrued interest, for the debentures. The aggregate amount realized by the Bank for the securities Lutz claims the Bank converted is, therefore:

| | |
|----------------------------------|-------------|
| 391.04 shares @ 44.04..... | \$17,221.40 |
| \$7,821 debentures at face | 7,821.00 |
| Total | \$25,042.40 |

As of the date of incorporation of the trailer business the aggregate amount of the partnership obligations owing Sheldon were \$77,200.00, of which \$57,200.00 constituted advances and \$20,000.00 (based on the lower of the two independent expert valuations) executive compensation. The consent to incorporation having been set aside by Lutz, his share of the partnership indebtedness owing Sheldon as of February 1, 1955 was 9% of \$77,200.00 or \$6,948.00. Debiting the amount of the conversion damages in that sum, the result obtained is

\$18,094.40. This amount together with interest from May 8, 1956, is the maximum award realizable by plaintiff under the evidence and the law. The district court awarded plaintiff the sum of \$31,566.25 as conversion damages, together with interest from December 10, 1959. [Clk. Tr. 609, lines 12-17.] In so doing, it committed judicial error.

Conclusion.

For the foregoing reasons, it is respectfully submitted that the judgment of the district court should be reversed and the case remanded with instructions to the court to enter a judgment in favor of plaintiff in a sum not to exceed \$18,094.40.

Respectfully submitted,

LAWLER, FELIX & HALL,
ROBERT HENIGSON,

Attorneys for Appellant Security First National Bank, as Executor of the Will of Ben H. Sheldon, Deceased.

Certificate.

I certify that, in connection with the preparation of this brief, I have examined Rules 18 and 19 of the United States Court of Appeals for the Ninth Circuit, and that, in my opinion, the foregoing brief is in full compliance with those rules.

ROBERT HENIGSON.



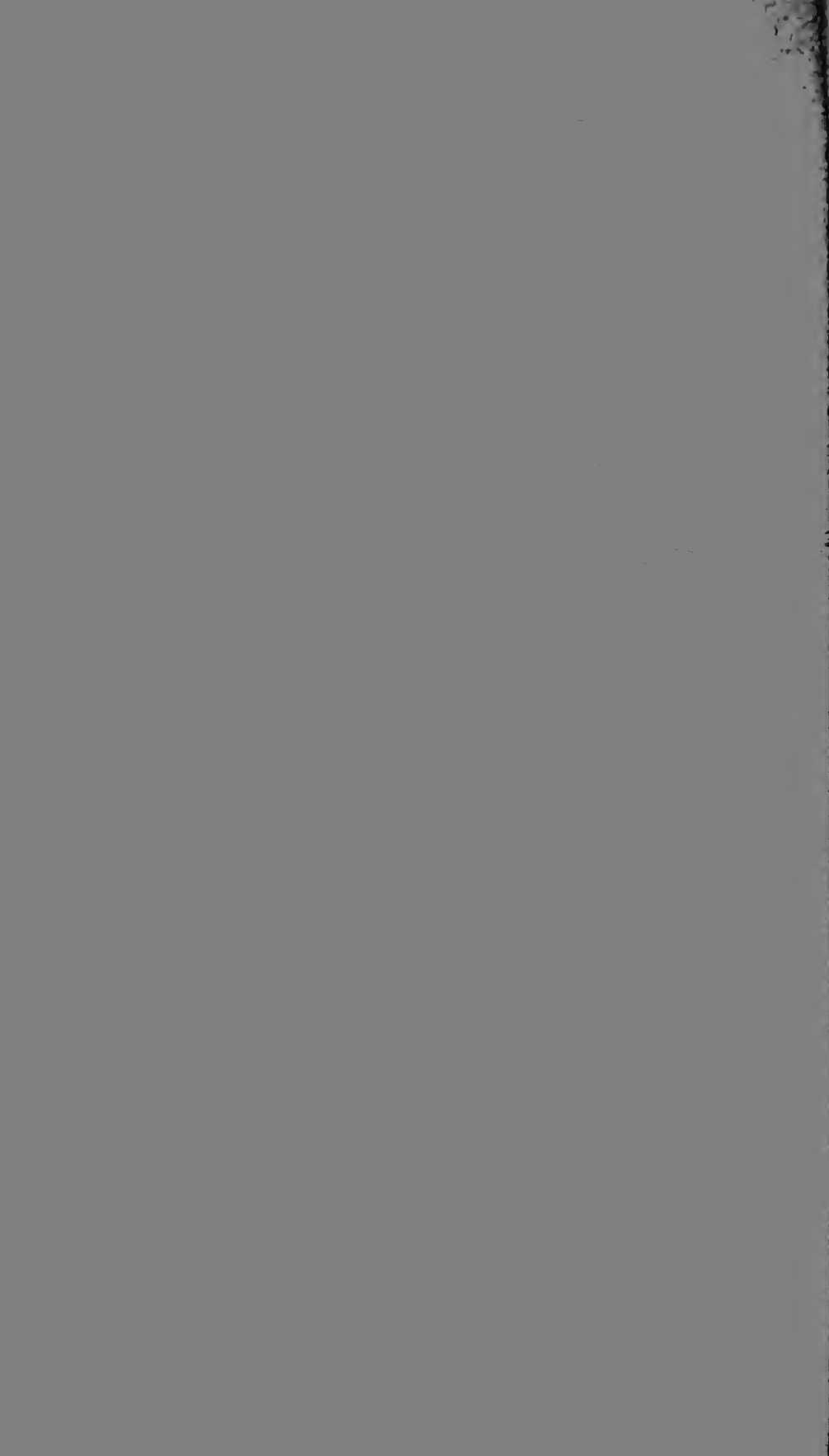

APPENDIX 1.

EXHIBITS

(Rule 18(2)(f) of the Rules of the United States Court of Appeals for the Ninth Circuit.)

[Note: The exhibits marked by an asterisk (*) were stricken from the record as against the Bank as executor only by order of the District Court [R. 179].]

| Exhibit Number | Received for Identification | Offered into Evidence | Received into Evidence |
|----------------|-----------------------------|-----------------------|------------------------|
| 1 | R. Supp. 6 | R. 663 | R. 665 |
| 2 | " | " | " |
| 3 | " | " | " |
| 4 | " | " | " |
| 5 | " | " | " |
| 6 | " | " | " |
| 7 | " | " | " |
| 8 | " | " | " |
| 9 | " | " | " |
| 10 | " | " | " |
| 11 | " | " | " |
| 12 | " | " | " |
| 13 | " | " | " |
| 14 | " | " | " |
| 15 | " | " | " |
| 16 | " | " | " |
| 17 | " | " | " |
| 18 | " | " | " |
| 19 | " | " | " |
| 20 | " | " | " |
| 21 | " | " | " |
| 22 | " | " | " |

| Exhibit Number | Received for Identification | Offered into Evidence | Received into Evidence |
|-------------------|--------------------------------|-----------------------------|------------------------------|
| 23 | “ | “ | “ |
| 24 | “ | “ | “ |
| 25 | “ | “ | “ |
| 26 | “ | “ | “ |
| 27 | “ | “ | “ |
| 28 | “ | “ | “ |
| 29 | “ | “ | “ |
| 30 | “ | “ | “ |
| 31 | “ | “ | “ |
| 32 | “ | “ | “ |
| 33 | “ | “ | “ |
| 34 | “ | “ | “ |
| 35 | “ | “ | “ |
| 36 | “ | “ | “ |
| 37 | “ | “ | “ |
| 38 | “ | “ | “ |
| 39 | “ | “ | “ |
| 40 | “ | “ | “ |
| 41 | “ | “ | “ |
| 42 | “ | “ | “ |
| 43 | “ | “ | “ |
| 44 | “ | “ | “ |
| 45 | “ | “ | “ |
| 46 | “ | “ | “ |
| 47 | “ | “ | “ |
| 48 | “ | “ | “ |
| 49 | “ | “ | “ |
| 50 | “ | “ | “ |
| 51 | “ | “ | “ |

| Exhibit Number | Received for Identification | Offered into Evidence | Received into Evidence |
|-------------------|--------------------------------|-----------------------------|------------------------------|
| 52 | “ | “ | “ |
| 53 | “ | “ | “ |
| 54 | “ | “ | “ |
| 55 | “ | ----- | ----- |
| 56 | “ | ----- | ----- |
| 57 | “ | R. 663 | R. 665 |
| 58 | “ | “ | “ |
| 59 | “ | “ | “ |
| 60 | “ | “ | “ |
| 61 | “ | “ | “ |
| 62 | “ | “ | “ |
| 63 | “ | “ | “ |
| 64 | “ | “ | “ |
| 65 | “ | “ | “ |
| 66 | “ | “ | “ |
| 67 | “ | “ | “ |
| 68 | “ | “ | “ |
| 69 | “ | “ | “ |
| 70 | “ | “ | “ |
| 71 | “ | “ | “ |
| 72 | “ | “ | “ |
| 73 | “ | “ | “ |
| 74 | “ | “ | “ |
| 75 | “ | “ | “ |
| 76 | “ | “ | “ |
| 77 | “ | “ | “ |
| 78 | “ | “ | “ |
| 79 | “ | ----- | ----- |
| 80 | “ | “ | “ |

| Exhibit Number | Received for Identification | Offered into Evidence | Received into Evidence |
|-------------------|--------------------------------|-----------------------------|------------------------------|
| 81 | “ | “ | “ |
| 82 | “ | “ | “ |
| 83 | “ | “ | “ |
| 84 | “ | “ | “ |
| 85 | “ | “ | “ |
| 86 | “ | “ | “ |
| 87 | “ | “ | “ |
| 88 | “ | “ | “ |
| 89 | “ | “ | “ |
| 90 | “ | “ | “ |
| 91 | “ | “ | “ |
| 92 | | R. 665 | R. 667 |
| 93 | R. 338 | “ | “ |
| 94 | R. 345 | “ | “ |
| 95 | R. 344 | “ | “ |
| 96 | | “ | “ |
| 97 | R. 352 | “ | “ |
| 97A | R. 473 | “ | “ |
| 98 | | “ | “ |
| 99 | | “ | “ |
| 99A | R. 471 | “ | “ |
| 100 | | “ | “ |
| 101 | | “ | “ |
| 102 | R. 360 | “ | “ |
| 103 | | “ | “ |
| 104 | | “ | “ |
| 105 | | “ | “ |
| 106 | | “ | “ |
| 107 | R. 361 | “ | “ |

| Exhibit Number | Received for Identification | Offered into Evidence | Received into Evidence |
|-------------------|--------------------------------|-----------------------------|------------------------------|
| 108 | R. 362 | “ | “ |
| 109 | R. 364 | “ | “ |
| 110 | | “ | “ |
| 111 | R. 367 | “ | “ |
| 112 | | “ | “ |
| 113 | R. 368 | “ | “ |
| 114 | | “ | “ |
| 115 | | “ | “ |
| 116 | | “ | “ |
| 117 | | “ | “ |
| 118* | | “ | “ |
| 119* | | “ | “ |
| 120* | | “ | “ |
| 121* | | “ | “ |
| 122* | R. 376 | “ | “ |
| 123* | R. 378 | “ | “ |
| 124 | | “ | “ |
| 125* | | “ | “ |
| 126* | | “ | “ |
| 127* | | “ | “ |
| 128* | R. 380 | “ | “ |
| 129* | | “ | “ |
| 130* | R. 383 | “ | “ |
| 131 | | “ | “ |
| 132 | | “ | “ |
| 133 | | “ | “ |
| 134 | | “ | “ |
| 135* | | “ | “ |
| 136* | | “ | “ |

| Exhibit Number | Received for Identification | Offered into Evidence | Received into Evidence |
|----------------|-----------------------------|-----------------------|------------------------|
| 137 | ----- | “ | “ |
| 138 | ----- | “ | “ |
| 139 | R. 407 | R. 432 | R. 433 |
| 140 | R. 408 | “ | “ |
| 141 | R. 412 | “ | “ |
| 142 | R. 412 | “ | “ |
| 143 | R. 417 | “ | “ |
| 144 | R. 418 | “ | “ |
| 145 | R. 418 | “ | “ |
| 146 | ----- | “ | “ |
| 147 | R. 419 | “ | “ |
| 148 | R. 419 | “ | “ |
| 149 | R. 420 | “ | “ |
| 150 | R. 420 | “ | “ |
| 151 | R. 421 | “ | “ |
| 152 | R. 421 | “ | “ |
| 153 | R. 421 | “ | “ |
| 153A | ----- | R. 700 | R. 700 |
| 154 | R. 422 | R. 432 | R. 433 |
| 155 | R. 423 | “ | “ |
| 156 | R. 423 | “ | “ |
| 157 | R. 423 | R. 432 | R. 433 |
| 158 | 424 | “ | “ |
| 159 | 424 | “ | “ |
| 160 | 425 | “ | “ |
| 161 | 425 | “ | “ |
| 162 | 426 | “ | “ |
| 162A | 426 | “ | “ |
| 163 | 428 | “ | “ |
| 164 | “ | “ | “ |
| 165 | “ | “ | “ |

| Exhibit Number | Received for Identification | Offered into Evidence | Received into Evidence |
|----------------|-----------------------------|-----------------------|------------------------|
| 166 | “ | “ | “ |
| 167 | “ | “ | “ |
| 168 | “ | “ | “ |
| 168A | R. 432 | ----- | ----- |
| 169 | R. 429 | R. 432 | R. 433 |
| 170 | “ | “ | “ |
| 171 | “ | “ | “ |
| 172 | “ | “ | “ |
| 173 | R. 430 | “ | “ |
| 174 | “ | “ | “ |
| 175 | “ | “ | “ |
| 176 | “ | “ | “ |
| 177 | “ | “ | “ |
| 178 | “ | “ | “ |
| 179 | ----- | R. 667 | R. 668 |
| 180 | ----- | R. 667 | R. 668 |
| 181 | ----- | “ | “ |
| 182 | ----- | “ | “ |
| 183 | ----- | “ | “ |
| 184 | ----- | “ | “ |
| 185 | ----- | “ | “ |
| 186 | ----- | “ | “ |
| 187 | ----- | “ | “ |
| 188 | ----- | “ | “ |
| 189 | ----- | “ | “ |
| 190 | ----- | “ | “ |
| 191 | ----- | “ | “ |
| 192 | ----- | “ | “ |
| 193 | ----- | “ | “ |

| Exhibit Number | Received for Identification | Offered into Evidence | Received into Evidence |
|----------------|-----------------------------|-----------------------|------------------------|
| 194 | | “ | “ |
| 195 | R. Supp. 22 | R. 668 | R. 668 |
| 196 | R. Supp. 23 | R. 668 | R. 668 |
| 197 | R. Supp. 39 | R. 668 | R. 669 |
| 198 | R. Supp. 41 | R. 670 | R. 670 |
| 199 | R. Supp. 67 | | |
| 200 | R. 355 | R. 670 | R. 670 |
| 201 | R. 385 | R. 386 | R. 386 |
| 202 | R. 385 | R. 386 | R. 386 |
| 203 | R. 385 | R. 386 | R. 386 |
| 204 | R. 519 | R. 671 | R. 676 |
| 205 | R. 519 | R. 671 | R. 676 |
| 205A | R. 520 | “ | “ |
| 205B | R. 520 | “ | “ |
| 206 | R. 520 | “ | “ |
| 207 | R. 520 | “ | “ |
| 208 | R. 521 | “ | “ |
| 209 | R. 521 | “ | “ |
| 210 | R. 531 | “ | “ |
| 211 | R. 531 | “ | “ |
| 212 | R. 603 | R. 676 | R. 676 |
| 213 | R. 607 | R. 676 | R. 678 |
| 214 | R. 639 | R. 678 | R. 678 |
| 215 | | | |
| 216 | | | |
| 217 | R. 659 | R. 679 | R. 680 |
| 218 | | R. 680 | Withdrawn |
| 219 | R. 689 | | |
| 220 | R. 698 | R. 699 | R. 699 |
| 222 | R. Tr. 35 | R. Tr. 35 | R. Tr. 35 |

| Exhibit Number | Received for Identification | Offered into Evidence | Received into Evidence |
|----------------|-----------------------------|-----------------------|------------------------|
|----------------|-----------------------------|-----------------------|------------------------|

Bank as Executor

| | | | |
|-------|--------|--------|--------|
| AA | R. 795 | R. 796 | R. 796 |
| A | R. 543 | | |
| B | R. 556 | | |
| C | R. 559 | | |
| D-K | | | |
| L | | R. 703 | R. 703 |
| M-1 | R. 703 | R. 704 | R. 704 |
| N-1 | | R. 705 | R. 705 |
| N-2 | | R. 705 | R. 705 |
| Q-1-7 | | | |
| R-1 | R. 538 | | |
| S-1 | R. 502 | | |
| S-2 | R. 502 | | |
| T | | R. 713 | R. 713 |
| U | | R. 713 | R. 714 |
| V | | | |
| X | | R. 711 | R. 711 |
| Y | | R. 711 | R. 711 |
| Z | R. 752 | R. 753 | R. 753 |

Mae Sheldon

| | | | |
|---|------------|------------|-----------------|
| A | | R. 786 | R. 787—Rejected |
| B | | R. 786 | R. 787—Rejected |
| C | | R. 786 | R. 787—Rejected |
| D | | R. 787 | R. 787 |
| E | R. Tr. 103 | R. Tr. 103 | R. Tr. 103 |

James Thompson

| | | | |
|---|--------|--------|--------|
| G | R. 403 | | |
| H | R. 452 | R. 455 | R. 455 |

All of the exhibits above listed as to which there is no record designation, with the sole exception of Thompson's G, were offered and received in evidence (unless otherwise specifically noted). Agreeably with Rule 17(6) of the Rules of this Court, only those portions of the record material to the consideration of the points raised on appeal were designated to be included in the printed transcript. As a result, the printed transcript of record does not include all the references necessary to complete the table. *E.g.*, defendant Bank's S-1 and S-2 were offered and received in evidence on June 5, 1959, as reported in Volume 3 of the reporter's transcript at page 332 thereof, but that page, having no particular significance to the issues raised on this appeal, was not included in the printed record.

TOPICAL INDEX

| | PAGE |
|---|------|
| Jurisdictional statement | 1 |
| Statement and facts of the case..... | 2 |
| Specification of errors relied on..... | 4 |
| Question presented | 5 |
| Summary of argument..... | 5 |
| Argument | 10 |
| I. | |
| The findings of fact are not supported by the evidence..... | 10 |
| Appellee's witnesses | 10 |
| Appellants' witnesses | 12 |
| II. | |
| The findings of fact, in particular those relating to the measure and amount of damages, are vague, indefinite and contradictory | 15 |
| III. | |
| The findings of fact purport to refute and deny matters deemed settled by this court, in derogation of the rule of law of the case..... | 20 |
| IV. | |
| The judgment is not supported by the evidence and is unjust and excessive | 22 |
| Conclusion | 25 |

TABLE OF AUTHORITIES CITED

| CASES | PAGE |
|---|-----------|
| Aetna Life Ins. Co. v. Wharton, 63 F. 2d 378..... | 22 |
| Alexander v. Nash-Kelvinator Corporation, 261 F. 2d 187.... | |
| | 9, 18, 23 |
| American Eagle Fire Ins. Co. v. Eagle Star Ins. Co., 216 F. 2d 176..... | 15 |
| Commercial Standard Insurance Co. v. Liberty Plan Co., 283 F. 2d 893..... | 17 |
| Daido Line v. Thomas P. Gonzalez Corp., 299 F. 2d 669..... | 7, 20 |
| Farley v. United States, 252 F. 2d 85..... | 20 |
| National Lead Co. v. Western Lead Products Co., 291 F. 2d 447..... | 17 |
| Riddell v. Guggenheim, 281 F. 2d 836..... | 15 |
| Thompson v. Maxwell Land Grant & Railway Company, 168 U. S. 451, 18 S. Ct. 121, 42 L. Ed. 539..... | 8, 21 |
| United States v. El-O-Pathic Pharmacy, 192 F. 2d 62..... | 15 |
| United States v. Horsfall, 270 F. 2d 107..... | 19 |
| United States v. United States Gypsum Co., 333 U. S. 364, 68 S. Ct. 525, 92 L. Ed. 746..... | 6, 15 |
| Welsh Company of California v. Strolee of California, Inc., 290 F. 2d 509..... | 7, 16 |

STATUTES

| | |
|--|---|
| United States Code, Title 28, Sec. 1291..... | 1 |
| United States Code, Title 28, Sec. 1332..... | 1 |

No. 18174

IN THE

United States Court of Appeals

FOR THE NINTH CIRCUIT

SECURITY FIRST NATIONAL BANK OF LOS ANGELES,
as Executor of the Will of Benjamin Harrison
Sheldon, MAE SHELDON and ROBERT HOHLY,

Appellants and Cross-Appellees,

vs.

EVA S. LUTZ, as Administratrix of the Estate of
Walter A. Lutz, Deceased,

Appellee and Cross-Appellant.

OPENING BRIEF OF APPELLANT ROBERT HOHLY.

Jurisdictional Statement.

Jurisdiction of the District Court was based upon diversity of citizenship and an amount in controversy which exceeds the sum of \$10,000.00, exclusive of interest and costs. Appellee's decedent was a citizen of the State of Washington and each of the appellants is a citizen of California for diversity purposes (the action was commenced prior to the effective date of the 1958 amendment to 28 U. S. C. 1332) [R. 153-154].

Jurisdiction on appeal is based on 28 U. S. C. 1291.

Statement and Facts of the Case.

This cause comes up on appeal for the second time, after being remanded back to the United States District Court, Southern District of California, Central Division, by this Honorable Court, for the purpose of preparing new findings on the issue of damages. The first appeal is reported in 297 F. 2d 159, and is hereafter referred to as the Opinion.

Appellant Robert Hohly is one of three defendants who are again appealing the amount of the new judgment, and files this brief solely on his own behalf and for no other party.

Since the remand, the original appellee Walter A. Lutz died, and Eva S. Lutz, the administratrix of his estate, was substituted in his stead. Said administratrix, hereinafter called appellee, has also filed notice of an intention to cross-appeal.

The basic facts relating to this new appeal require little detail. In its Opinion, this Honorable Court found that appellant Security First National Bank of Los Angeles, in the representative role of executor of the estate of Benjamin Harrison Sheldon, hereinafter called Bank, was liable to appellee out of Ben Sheldon's estate for conversion perpetrated by Sheldon in respect to the proper proportion of Walter A. Lutz's interest as a limited partner in the B. H. Sheldon Co., a trailer manufacturing partnership, later incorporated under the same name. Appellant Mae Sheldon was found to be similarly liable.

Appellant Hohly, who was expressly found by this Court not to have profited personally from the acts of the other two appellants, was held liable for such

“neglect of duty” in preparing certain books and records, in his role as accountant for the partnership and corporate entities as, perhaps, to have made it possible for the perpetration of the conversions complained of against the other two appellants.

However, this Court remanded the cause back to the district Court on the theory that since the sum of the initial judgment against the appellants was evolved from appellee’s theory that upon equitable principles appellee should be permitted to avoid the consequences of his consent to the subsequent incorporation, and thus treat the corporate entity as a continuation of the initial partnership, “equitable consideration must be given to the rights of (Ben) Sheldon, restored to him in the eyes of equity by that very avoidance” [Opinion p. 163]. Or, as this Court thereafter specifically defined the issue of “equitable consideration” of Ben Sheldon’s rights: The precise matter to be determined, as was not done at the first trial, was “the reasonable value of the services rendered by Sheldon and the amount of compensation to which he was entitled [Opinion p. 165] in his role as chief executive of the trailer business. Concededly, as this Court noted [Opinion p. 165]. “Sheldon received (some) salary and expenses from the corporation” [Opinion p. 165] while the business was maintained as a corporate entity; but Sheldon had received no salary whatsoever for the seven month period while the business was operated as a partnership and managed by Sheldon, as a general partner: “The Court: Now, there was no salary actually drawn for that seven month period . . .” [Tr. 70: 6-8].¹

¹The district court held two hearings following the remand, February 19, 1962 and March 19, 1962. No evidence was, how-

The precise dates when said seven month period commenced and terminated were July 1, 1954 to January 31, 1955; and the period of time relating to the corporate entity was from February 1, 1955 to Sheldon's death, March 3, 1956. The former period is hereinafter referred to as the seven month period and the latter as the thirteen month period, in accordance with the stipulation of all counsel and the district Court at the first hearing.

Appellant Hohly has been informed that appellant Bank intends to offer a more detailed statement of fact than is herein given and in the interest of brevity adopts such statement in respect to all factual matters herein omitted.

Specification of Errors Relied on.

1. The findings of fact filed by the district Court are not supported by the evidence.
2. The findings of fact filed by the district Court are vague, indefinite, contradictory and conclusionary.
3. The findings of fact filed by the district Court refute and deny matters which have already been settled by this Court on the first appeal and have become the law of the case.
4. The judgment against appellant Hohly is not supported either by the findings of fact filed by the district Court or by the evidence, and is erroneous and excessive.

ever, taken at the first hearing. For convenience, all references to the transcript of the second hearing will be identified by the letter "T", followed by the page and line numbers referred to, separated by a colon. References to the first hearing will be preceded by the designation "T1"; and references to the Supplemental Transcript of Record on Appeal, containing pleading documents and exhibits filed subsequent to the remand, will be preceded by the designation "S.T."

Question Presented.

What remedies are open to, and will be afforded to, parties still aggrieved after a retrial, when although this Court has remanded a cause to a district Court for the express purpose of making findings of fact on certain issues, the district Court has failed to comply with the intended objective of the remand.

Summary of Argument.

After this Honorable Court remanded the cause back to the district Court on the issue of damages, to effect a "balancing of the equities" between the interests of Ben Sheldon and appellee's decedent, the district Court heard testimony on the reasonable value of Ben Sheldon's services as the executive officer in charge of all the operations of the trailer business. For convenience these services were related to two separate periods of time: a seven month period while the trailer business was conducted as a partnership, and a thirteen month period during which time the business was incorporated.

At the retrial appellee offered no evidence in respect to the value of Ben Sheldon's services during these periods. She did, however, call one witness who testified that "in the spring of '54 Ben Sheldon said he would not draw a salary." That was the full extent of the testimony.

Appellants, however, produced three expert witnesses. One reiterated his testimony offered at the first trial that Sheldon's services for the seven month period were worth \$30,000 to \$35,000 and \$70,000 to \$90,000 for the thirteen months. The second testified that the value of Sheldon's services should be placed at \$22,000 for the seven month period and \$71,500 for the thirteen

month period. The third expert testified that the services should be valued at \$20,000 and \$77,000 respectively, for the periods at issue.

At the conclusion of the retrial, the district Court filed its findings of fact which found the value of Sheldon's services to be in "a maximum not to exceed \$600 per month" — or \$4,200 for the seven month period and \$7,800 for the thirteen months.

Patently, since the district Court actually heard no evidence whatsoever substantiating the mere \$600 per month figure, it is apparent that the Court drew its own independent conclusion and arbitrarily adopted a figure to its own preference.

Findings which have no support in the evidence are, of course, erroneous and must be reversed on appeal. *United States v. United States Gypsum Co.*, 333 U. S. 364, 68 S. Ct. 525, 92 L. Ed. 746.

But actually, even this \$600 per month figure, cited in some of the findings, is adversely contradicted and qualified in the same findings by limiting clauses, such as "assuming he (Sheldon) had an equitable right to any salary at all"; and still other findings of fact specifically hold that Sheldon was definitely not entitled to any salary whatsoever. Thus abject contradiction on the issue runs through the findings relating thereto.

The other findings of fact not specifically directed toward the matter of the value of Sheldon's services are similarly vague, indefinite, conclusionary and contradictory.

Findings of this type have often been criticized and reversed by this Court. See *Welsh Company of California v. Strolee of California, Inc.*, 290 F. 2d 509.

The errors in the findings of fact heretofore described are particularly prevelant in those other findings relating to the actual detriment suffered by appellee, and to the measure of damages to be assessed against appellant Hohly. Six different findings state some nine different sums purporting to be the detriment suffered by appellee; ranging from \$15,300 to \$126,760.-27. Then, the very last finding states that appellant Hohly is found liable for damages in the round sum of \$55,000; an amount which remains totally unsupported and unsubstantiated by a single figure or computation to be found anywhere throughout all the findings of fact.

Clearly, such a veritable mish-mash of figures and declarations of detriment and damage fails to afford appellant Hohly any possible means of determining how the actual damage total of \$55,000 has been evolved.

Nor is this Court, on appeal, in any better position to understand, from the confused and contradictory figures in the findings, how the \$55,000 damage figure was reached. Findings in such a form have been criticized and remanded by this Court in *Daido Line v. Thomas P. Gonzalez Corp.*, 299 F. 2d 669, and other decisions.

Certain of the findings of fact are further in error in that they now deny that while balancing the equities

Ben Sheldon should be credited with a loan to the business in the sum of \$57,200, which was never repaid. Although original finding of fact 20, filed by the district Court after the first trial, unequivocally finds that said sum was a loan, not repaid, new finding of fact 11, filed by the district Court after remand, now finds that "such \$57,200. is not a loan, nor a proper equitable offset".

Actually, since this Court has already itself determined in its Opinion that the \$57,200 was a loan, and must be given consideration while balancing the equities, and since no new evidence was taken on this matter on retrial, the pronouncement by this Court has become the rule of the case, and cannot now be contrarily decided by the District Court. See *Thompson v. Maxwell Land Grant & Railway Company*, 168 U. S. 451, 18 S. Ct. 121, 42 L. Ed. 539.

As shown, appellant Hohly has been found liable for a judgment in the sum of \$55,000 without any justification for such in the evidence heard by the district Court or from the computations on damages made in the findings of fact. Actually, this damage sum totals some \$8,500 more than appellant Hohly was assessed in the first judgment, even including the sum of \$15,000 for exemplary damages therein assessed against him.

Thus, although this Court reversed the award of punitive damages against appellant Hohly, he is now in a considerably worsened position, in respect to the total

liability assessed against him by the district Court, then he was even before his successful appeal.

The new judgment is clearly excessive and should be reversed.

However, in the interest of bringing an end to this litigation, which has now extended some four and one-half years from the time it first came to trial, all three defendant appellants herein have conferred and have agreed that the proper measure of damages to be assessed against them, jointly and severally, is the sum of \$18,094.40. The formula from which this sum is evolved is given in detail in the Argument in this brief.

If this Court desires, it may, as did the Second Circuit in *Alexander v. Nash-Kelvinator Corporation*, 261 F. 2d 524, finalize the amount of damages for itself and order a remittitur in this amount, without need for any further remand. In the *Alexander* case, the Court followed this procedure, after a similar second appeal following an initial remand on the issue of damages.

ARGUMENT.

I.

The Findings of Fact Are Not Supported by the Evidence.

Undisputedly, as this Court, the district Court, and all parties have recognized, the precise factual issue to be determined at the new trial, in order to “balance the equities” and properly to assess damages, was the proper amount of salary to which Ben Sheldon was entitled for the seven month period (for which he had drawn no salary) and the thirteen month period for which he had drawn some \$76,800 [T1. 49: 8-9].

Accordingly, at the second hearing, more accurately described as the new trial, evidence was offered on this issue of the value of Sheldon’s services. Because appellant Hohly is urging as a major ground on appeal that the supplemental findings of fact² are not supported by the evidence (as well as being legally objectionable on other grounds, see *infra*), it is believed to be essential that the actual evidence heard by the district Court be reviewed. (Objections to the findings of fact were made to the District Court by appellants [S. T. 584-590], but these were denied).

Appellee’s Witnesses.

Appellee called three witnesses: Dean Sidney Curtis, Julius Leonard Merrifield and Donald Richard Villee.

Dean Sidney Curtis: This witness, who had been a limited partner in the partnership enterprise, testified merely that “in the spring of ’54” [T.

²The supplemental findings of fact are, of course, those filed by the district court after the retrial, as included in the new Clerk’s Transcript.

7:3] Ben Sheldon said “that he would not draw a salary” [T. 6:24].

And this is the extent of the testimony offered by the witness on the point. Though it clearly appears from the tenor of the language of some of the supplemental findings of fact that the district Court has drawn the inference from such bare testimony that Ben Sheldon was therefore *not entitled* to receive any salary whatsoever at any time, clearly such an inference is not supported by the bare statement of the witness heretofore cited. Patently the testimony given fatally lacks detail as to for what period of time Sheldon purportedly intended not to draw a salary (perhaps it could have been for one week); and when Sheldon changed his mind—since there is undisputed evidence that subsequently Sheldon did receive some salary.

Julius Leonard Merrifield: This witness, an employee of the trailer business, gave no testimony whatsoever about the value of Ben Sheldon’s services; and appellee’s counsel’s questions on direct, and the witness’ answers, were substantially irrelevant — being directed almost exclusively toward explaining what the witness’ own duties were in the business.

On cross-examination, however, this witness admitted the following in respect to *Ben Sheldon’s* duties in the operation of the business:

1. Sheldon was the chief executive officer of the business entities [T. 22:1-6] and [T. 24:13-15].
2. Sheldon exclusively contacted dealers to franchise the manufactured trailers and arranged for the manu-

facture and delivery of the units to the franchised dealers [T. 22:16-22].

3. Sheldon negotiated all the agreements and contracts with the dealers [T. 22:23-25].

4. Sheldon participated in the design of the trailers [T. 24:24 to 25:1].

5. Sheldon was the chief financial officer for the business, made arrangements for the finances and "saw where the money came from that paid the bills" [T. 25:2-7].

6. Sheldon assumed full responsibility for the conduct of the business [T. 25:8-11].

7. Although the witness' services to the business were confined to a subsidiary role in sales and purchasing [T. 17:1-4] (a very small part of the overall operation), the witness himself received a salary which averaged \$650 per month [T. 25:16-21].

Donald R. Vilce: This witness, an accountant, who was called in by appellee to examine some of the business books and records, also gave no testimony whatsoever about the value of Ben Sheldon's services. His chief testimony concerned an entry he had found in the books which disclosed a salary payment of \$4,776.07 to Sheldon during the month of February, 1955.

Appellants' Witnesses.

Appellants called three witnesses: Robert Hohly, James Leroy Harner and Page E. Golsan.

Robert Hohly: Appellant Hohly, who had been the accountant for the business, testified to the following matters relating to Ben Sheldon's services:

1. Prior to the commencement of the seven

month period, there had been 84 employees in the business and by the time of Sheldon's death there were 282 [T. 49:23 to 50:1].

2. One L. B. McKinney, merely an administrative assistant to Sheldon, drew a salary of \$76,389.44 during the full twenty months in issue [T. 51:4-8].

3. Sheldon exclusively contacted the individual trailer dealers, negotiated the sale of the trailers and handled the financing of the business enterprise during the entire twenty months in issue [T. 52:9-20].

4. At the end of the twenty month period, the trailer business was the largest on the Pacific Coast [T. 59:25 to 60:3].

(At the original trial Hohly had testified that "a salary from \$30,000 to \$35,000 would be reasonable" for the seven month period [R. 826] and \$70,000 to \$90,000 for the thirteen months [R. 825]; and the district court acknowledged this testimony at the February, 1962 hearing: "He said it was \$5,000 a month . . . That is in the record." [Tl. 62:4-6]).

James Leroy Harner: This witness, a consultant in the field of industrial relations pertaining to executive compensation (including the recommending of salary levels for executive personnel for client firms [T. 66:8-15]), testified, in answer to an opinion question which detailed Sheldon's duties and services to the business, that for the thirteen month period a reasonable salary for Sheldon would be \$71,500 [T. 73:5-6] and for the seven month period, \$22,000 [T. 74:1-3].

Page E. Golsan: This witness, a consulting management engineer [T. 79:22], who during his business life had reviewed 800 to 900 reports dealing directly with the compensation of top executives [T. 81:10-15] testified, in answer to a similar opinion question which reviewed Sheldon's duties and services, that \$77,000 would be the reasonable value of Sheldon's services for the thirteen month period [T. 84:5-11], and \$20,000 for the seven month period [T. 88:11-16].

The foregoing, then, is the entire testimony heard by the district Court on the subject of the reasonable value of Ben Sheldon's services. Nevertheless, the Court thereafter filed findings of fact 1(a), 7 and 9 [S.T. 600, 603, 604], in which it declared that "a maximum reasonable salary for B. H. Sheldon's services . . . under the circumstances in evidence does not exceed \$600 per month."

Since it is clear, from a review of the foregoing testimony, that the district Court heard no evidence whatsoever to support the figure of merely \$600 per month, it therefore must be assumed that the Court arbitrarily adopted that figure as its own personal conclusion. (And by what rationale the court did so; considering the undisputed testimony about Ben Sheldon's broad and extensive executive duties and services, offered even by appellee's witness, and the testimony that a subsidiary employee of the business had averaged \$650 in salary and that an administrative assistant had been paid \$76,389.44 for the 20 months at issue, or more than \$1,525 per month; frankly escapes appellant Hohly.)

Manifestly, findings of fact which have no support in the evidence cannot be recognized or upheld and must be reversed on appeal.

Indeed, the Supreme Court, in *United States v. United States Gypsum Co.*, 333 U. S. 364, 68 S. Ct. 525, 92 L. Ed. 746 (1948) has declared as follows, in respect to a finding which (unlike those at issue) had *some* support in the evidence; at page 395:

“(T)his Court may reverse findings of fact by a trial court where ‘clearly erroneous’ . . . A finding is ‘clearly erroneous’ when although there is evidence to support it, the reviewing Court on the entire evidence is left with the definite and firm conviction that a mistake has been committed.”

This Court has frequently declared itself in accord with this pronouncement. See: *Riddell v. Guggenheim*, 281 F. 2d 836 (9th Cir., 1960); *American Eagle Fire Ins. Co. v. Eagle Star Ins. Co.*, 216 F. 2d 176 (9th Cir., 1954); *United States v. El-O-Pathic Pharmacy*, 192 F. 2d 62 (9th Cir., 1951).

II.

The Findings of Fact, in Particular Those Relating to the Measure and Amount of Damages, Are Vague, Indefinite and Contradictory.

Yet, at most, the district Court’s findings only grudgingly concede even the \$600 per month valuation to Ben Sheldon’s services, and strongly qualify even this figure. Indeed, findings 7 and 9, which appear to commence with a clause recognizing the \$600 figure, conclude with a negating qualification in this respect; which in finding 9 is given as: “assuming he had an equitable right to any salary at all.” [S.T. 604:5-6].

Then the matter is further confused by findings 2, 4 and 6, which basically declare, in conclusionary form, that Ben Sheldon was actually not entitled to any salary for the periods in question. Indeed, finding 4 finds that: "Sheldon disclaimed and waived any right to salary, July 1, 1954 to March 3, 1956" [S.T. 602:4-5].

Under the circumstances, there can be little dispute that the various findings relating to the value of Sheldon's services are, at the very least, contradictory; and considering their indecisive and diffident language, it is questionable that they can be said to make any real finding on the issue at all.

The language of other findings of fact, particularly 1(b), 3, 5, 6, 7 and 8 [S.T. 597 through 603], appears to be similarly vague, indefinite, contradictory and conclusionary.

In *Welsh Company of California v. Strolee of California, Inc.*, 290 F. 2d 509 (9th Cir., 1961) this Court said, in vacating the judgment and remanding the cause, at page 511:

"(W)e think it is the duty of the District Court to find the facts and not to leave to us the heavy chore of reviewing sundry, contradictory assumptions any of which could have led to the conclusory statements misnamed Findings of Fact in the present record.

" 'Findings of fact are required under Rule 52(a), Federal Rules of Civil Procedure * * *. The findings should be so explicit as to give the appellate court a clear understanding of the basis of the trial court's decision and to enable it to determine the ground on which the trial court reached its decision' "

In accord: *National Lead Co. v. Western Lead Products Co.*, 291 F. 2d 447, 451 (9th Cir., 1961); *Commercial Standard Insurance Co. v. Liberty Plan Co.*, 283 F. 2d 893, 895 (10th Cir., 1960).

But this error of unclear, indefinite and contradictory findings of fact is particularly prevelant at bar in respect to those findings which purport to define the actual detriment suffered by appellee, and thus the amount of damages to be assessed against the appellants. Compare the language of the following findings:

Finding 1(c) [S. T. 600:25-32] declares that one element of damage, the value of the shares of stock found to have been converted, should be \$19,691.07.

Finding 1(d) [S. T. 601:2-10] declares that appellee was damaged to the extent of \$15,300, "in addition to any other damages caused by the Sheldon's fraud herein found"; (but nowhere else in the findings is the "in addition" clause translated into actual dollars and cents — and indeed, the qualifying term "any" preceding the words "other damages" suggests that no such "other damages" are actually under contemplation).

Finding 12 [S. T. 604:29 to 605:14] repeats the sum of \$15,300, but in this instance is followed by a different "in addition clause", which now suggests the addition to the \$15,300 of an entirely different sum than might result from the "in addition" clause of finding 1(d): "in addition to plaintiff's damages for conversion of the securities". Again, this latter clause remains undefined in actual dollars.

Finding 12. *second half* [S. T. 605:15 to 606:1] (presumably intended to be finding 13, since there is no other 13), contains *three* different figures as purported

detriment suffered by appellee: \$23,083.35, \$112,675.-79 and \$126,760.27, in turn.

Finding 16 [S. T. 606:13-23] declares the damages to be, insofar as appellant Hohly is concerned, an evenly rounded out \$55,000.

Appellant Hohly respectfully asks in respect to all the foregoing findings: What is the *actual* detriment suffered by appellee? *How, and on the basis of what computation, is Hohly's liability determined to be \$55,000?*

Surely appellant Hohly has the constitutional right, before being compelled to pay the damages assessed, to be informed just how the sum of the damages was actually determined, and clearly, the findings of fact filed by the district Court woefully fail to provide such information.

And now that appellant Hohly has appealed the amount of the damages, how is this Honorable Court itself going to be able to decide, from the actual state of the findings of fact, whether the damages assessed are correct, proper and just? In *Alexander v. Nash-Kelvinator Corporation*, 261 F. 2d 187 (2nd Cir., 1958) wherein the same problem occurred, it is said, in remanding the matter on the issue of damages, at page 191:

“This court is mindful of the principle so frequently reiterated that the question of the excessiveness of a jury verdict is to be determined by the trial court on a motion for a new trial. In such cases the trial court, in effect, occupies the position of a reviewing judge. He has the power to pass upon, set aside or even reduce by remittitur excessive awards. Where a case is tried by a judge

without a jury the defendant is deprived of this right. The first opportunity which an aggrieved defendant has in this respect in a non-jury trial is upon appeal. For these reasons it becomes most important that the trial court comply meticulously with the requirements of Rule 52(a) with respect to findings so that the appellate court can properly appraise the elements which entered into the award. Just as the trial judge passes upon possible passion or prejudice and all the other legal grounds for attacking excessive damages on the post-trial motion to set aside a jury verdict so on the appeal the appellate court should have some knowledge of the basis or theory upon which the trial judge acted. Without this information the defendant is unable properly to exercise the appellate rights conferred by statute and the court is equally unable to make appropriate appellate review.”

And in *United States v. Horsfall*, 270 F. 2d 107 (10th Cir., 1959) it is said, at page 110:

“The difficulty here is that it is impossible from the findings to determine whether there has been a duplicate award for loss of earnings. Such uncertainty prevents the appellate court from making an intelligent review of the sufficiency of the evidence. The Supreme Court has said that there ‘must be findings, in such detail and exactness as the nature of the case permits, of subsidiary facts on which the ultimate conclusion of fairness can rationally be predicated’.* When the findings are

*“*Kelley v. Everglades Drainage District*, 319 U. S. 415, 420, 63 S. Ct. 1141, 1144, 87 L. Ed. 1485. See also *Dalehite v. United States*, 346 U. S. 15, 24, note 8, 73 S. Ct. 956, 97 L. Ed. 1427.”

inadequate to permit a review of the sufficiency of the evidence they do not satisfy the principle so announced. There is a duty upon the court in a case tried without a jury to make proper findings and there is a duty on counsel for the prevailing party to see that proper findings are made and filed.”

This Court has frequently similarly ruled See: *Farley v. United States*, 252 F. 2d 85, 88 (9th Cir., 1958); *Daido Line v. Thomas P. Gonzalez Corp.*, 299 F. 2d 669, 676 (9th Cir., 1962).

III.

The Findings of Fact Purport to Refute and Deny Matters Deemed Settled by This Court, in Derogation of the Rule of Law of the Case.

The findings of fact are further erroneous, in that they now purport to refute and deny one phase of the problem relating to the balancing of the equities between Sheldon and Lutz which has already been completely resolved — the requirement that Sheldon be credited with the \$57,200 which he loaned to the partnership and which was never repaid.

Suddenly the district Court has reopened this subject in its findings, despite the fact that no new evidence was taken at the retrial in respect thereto; and has now declared in finding of fact 11 as follows [S. T. 604:25-28]:

“Under all the circumstances of this case, I find that B. H. Sheldon has no equities to which he, or anyone claiming through him, is entitled. Such \$57,200 is not a loan, nor a proper equitable offset”.

Inconsistently, however, in its initial paragraph in the findings of fact [S. T. 599:29-31] the Court also states that it is reaffirming its original findings of fact 1 through 40 inclusive; including, of course, finding 20, which states as follows [R. 207]:

“During the period from July 12, 1954 to January 25, 1955, Decedent made cash contributions to the partnership, B. H. Sheldon Company, in the total sum of \$67,200.00, of which \$10,000.00 was repaid to Decedent by said partnership, leaving a net or balance for said period of \$57,200.00.”

Aside from the error and contradiction of the district Court in this respect, the matter has anyhow already been deemed settled, insofar as this Court is concerned. In the Opinion, page 162, it is said:

“(C)redit should be given him (Sheldon) for the sums owing. . . . The Court found that the sum of \$57,200.00 was owing to Sheldon by the partnership for advances.”

Clearly, this issue, upon which no new evidence was taken on retrial, has become the law of the case and cannot now be disavowed and contrarily decided by the District Court.

In *Thompson v. Maxwell Land Grant & Railway Company*, 168 U. S. 451, 18 S. Ct. 121, 42 L. Ed. 539 the Supreme Court has said at page 456:

“It is the settled law of this Court, as of others, that whatever has been decided on one appeal or writ of error cannot be re-examined on a second appeal or writ of error brought in the same suit. The first decision has become the settled law of the case. *Supervisors v. Kennicott*, 94 U. S. 498, and

cases cited in the Opinion; *Clark v. Keith*, 106 U. S. 464; *Chaffin v. Taylor*, 116 U. S. 567; *Northern Pacific Railroad Company v. Ellis*, 144 U. S. 458; *Great Western Telegraph Co. v. Burnham*, 162 U. S. 339, 343”.

And in *Aetna Life Ins. Co. v. Wharton*, 63 F. 2d 378 (8 Cir., 1933) it is said at page 379:

“It is a well-established rule that the decision of an Appellate Court is the law of that case on the points presented, to be followed in all subsequent proceedings in that case, in both the trial and the appellate court (Citations).”

IV.

The Judgment Is Not Supported by the Evidence and Is Unjust and Excessive.

In the Revised Judgment [S. T. 609:23-26] appellant Hohly has been found liable for the sum of \$55,000. As has been shown, this figure is unsupported by any evidence or by any matter contained in the findings of fact; and appears to be an amount arbitrarily imposed and assessed by the district Court. Actually, *it represents a greater liability imposed on appellant Hohly now than was the original judgment*, even when the latter is augmented by the punitive damages which the district Court originally imposed, and which this Court has stricken from the first judgment.

In all frankness, appellant Hohly is convinced that insofar as the district Court is concerned, it is intended that he be held liable for the same original judgment, plus the sum of the initial exemplary damages, plus an extra \$8,500 or so; all rounded out to an even \$55,000;

— an alarmingly excessive sum which if the result of a jury verdict, would clearly be deemed to reflect passion and prejudice.

Certainly, the Revised Judgment makes obvious that the district Court has used the original judgment of \$31,566.25. as a starting point for assessing the current damages; for how else explain the fact that appellant Bank has been assessed the identical amount of the original judgment under the guise of conforming with the probate claim filed by appellee in Ben Sheldon's estate. After all, the claim as filed patently does not specify the sum \$31,566.25; but rather, as is shown by this Court in the Opinion, page 161 footnote 1, is seeking payment for the value of 390.98 shares of Sheldon Co. stock — *whatever that value be.*

For all the reasons shown, this Honorable Court should again reverse the judgment and once more remand the matter to the district Court to determine the correct and proper amount of the judgment. Yet there must sometime be an end to litigation, and perhaps at this point *this Court may prefer to determine the proper amount of the damages for itself*, and issue a remittitur in that sum; thus finally concluding the matter. If so, there is precedent for such a procedure.

In *Alexander v. Nash-Kelvinator Corporation*, 261 F. 2d 187 (2nd Cir., 1958) the cause was similarly remanded to the trial Court for new findings of fact on the issue of damages. Subsequently that court expressed an unwillingness to modify the damages and prepared new findings which reiterated the same sum as before. After a second appeal, the Second Circuit

However, in the interest of avoiding further litigation, appellant Hohly, in concurrence with the other defendant appellants, will readily accept any final determination in respect to the amount of the damages made by this Honorable Court. In such an event, it is believed that this Court will wish to follow the formula and reach the result hereinbefore detailed.

Respectfully submitted,
KIRTLAND & PACKARD,
FREDERICK P. BACKER, and
ABE MUTCHNIK,
Attorneys for Appellant Robert Hohly.

Certificate.

I certify that, in connection with the preparation of this brief, I have examined Rules 18 and 19 of the United States Court of Appeals for the Ninth Circuit, and that, in my opinion, the foregoing brief is in full compliance with those rules.

ABE MUTCHNIK

See also Vol. 3191

No 18177

United States Court of Appeals
For the Ninth Circuit

AMERIO CONTACT PLATE FREEZER, INC., *Appellant,*

vs.

BELT-ICE CORPORATION and FRANK W. KNOWLES,
Appellees.

APPEAL FROM THE UNITED STATES DISTRICT COURT FOR
THE WESTERN DISTRICT OF WASHINGTON
NORTHERN DIVISION

BRIEF OF APPELLEES

FILED

DEC 1 1932

FRANK H. SCHMID, CLERK

ALFRED J. SCHWEPPE

ROBERT W. BEACH

ARTHUR S. LANGLIE

Attorneys for Appellees.

657 Colman Building,
Seattle 4, Washington.

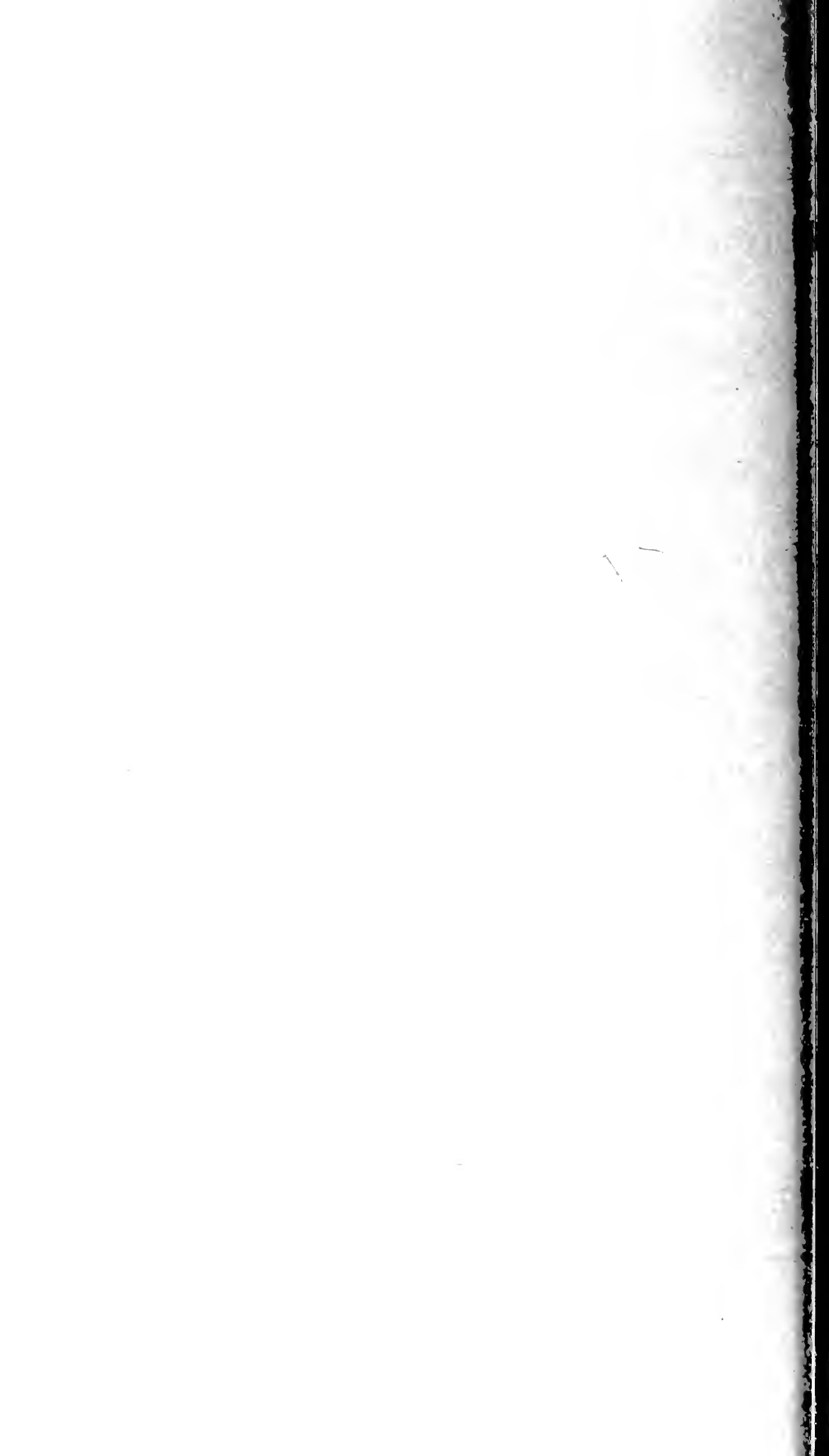

United States Court of Appeals
For the Ninth Circuit

AMERIO CONTACT PLATE FREEZER, INC., *Appellant,*

vs.

BELT-ICE CORPORATION and FRANK W. KNOWLES,
Appellees.

APPEAL FROM THE UNITED STATES DISTRICT COURT FOR
THE WESTERN DISTRICT OF WASHINGTON
NORTHERN DIVISION

BRIEF OF APPELLEES

ALFRED J. SCHWEPPE

ROBERT W. BEACH

ARTHUR S. LANGLIE

Attorneys for Appellees.

657 Colman Building,
Seattle 4, Washington.

| | |
|--|--------------------------|
| <i>Chicopee Mfg. Corp. v. Columbus Fiber Mills Co.</i> (D.C. Ga.) 165 F.Supp. 307 (1958)..... | 5, 14, 15, 16, 18, 19 |
| <i>Coakwell v. United States</i> , Ct. Cl., 292 F.2d 918 (1961) | 28 |
| <i>Connecticut Paper Products v. New York Paper Co.</i> (D.C. Md.) 39 F.Supp. 127 (1941)..... | 13 |
| <i>Covert v. Covert</i> (Circuit Court, W.D.N.Y.) 106 Fed. 183 (1901)..... | 4, 10, 11 |
| <i>Cryns v. Musher</i> , C.C.P.A., 161 F.2d 217 (1947)..... | 40 |
| <i>Dittgen v. Racine Paper Goods Co.</i> (D.C. Wis.) 181 Fed. 394 (1910) | 15 |
| <i>Egbert v. Lippmann</i> , 104 U.S. 333 (1881)..... | 12 |
| <i>Esso Standard Oil Co. v. Sun Oil Co.</i> , D.C. Cir., 229 F.2d 37 (1956)..... | 5 |
| <i>F. E. Myers & Bro. Co. v. Goulds Pumps</i> (D.C.N.Y.) 91 F.Supp. 475 (1950)..... | 13 |
| <i>Hutton v. Frank Krements Co.</i> , 3 Cir., 231 Fed. 973 (1916) | 19 |
| <i>Jenks v. Knight</i> , C.C.P.A., 90 F.2d 654 (1937)..... | |
| <i>Magee v. Coca-Cola Company</i> , 7 Cir., 232 F.2d 596 (1956) | 11, 18, 19 |
| <i>McCreery Engineering Company v. Massachusetts Fan Company</i> , 1 Cir., 105 Fed. 498 (1912)..... | 7, 8, 10 |
| <i>Metallizing Engineering Co. v. Kenyon Bearing & Auto Parts Co.</i> , 2 Cir., 153 F.2d 516 (1946)..... | 10 |
| <i>Paraffine Companies v. McEverlast, Inc.</i> , 9 Cir., 84 F.2d 335 (1936)..... | 4 |
| <i>Peerless Roll Leaf Co. v. H. Griffin & Sons</i> , 2 Cir., 29 F.2d 646 (1928)..... | 10 |
| <i>Philco Corporation v. Admiral Corporation</i> (D.C. Del.) 199 F.Supp. 797 (1961)..... | 16, 17, 19, 22, 23 |
| <i>Piet v. United States</i> (D.C.S.D. Cal.) 176 F.Supp. 576 (1959), modified 283 F.2d 693..... | 14 |
| <i>Rieser v. Williams</i> , C.C.P.A., 255 F.2d 419 (1958) | 35, 37 |
| <i>Safeway Stores, Inc. v. Dunnell</i> , 9 Cir., 172 F.2d 649 (1949) | 5 |
| <i>Schutte, In re</i> , C.C.P.A., 244 F.2d 323 (1957)..... | 40 |

TABLE OF CASES

v

Page

| | |
|--|------------|
| <i>Stalego et al. v. Heymes et al</i> , C.C.P.A., 263 F.2d 223 (1959) | 34-35 |
| <i>Tanke et al., In re</i> , C.C.P.A., 213 F.2d 551 (1954).... | 41 |
| <i>Thompson v. Hamilton</i> , C.C.P.A., 152 F.2d 994 (1946) | 38, 39, 40 |
| <i>Trico Products Corporation v. Delman Company</i> (D.C. Iowa) 199 F.Supp. 231 (1961)..... | 12, 15, 16 |
| <i>Vinco Corporation v. Wickman</i> (D.C. Mich.) 193 F.Supp. 516 (1959)..... | 42, 43 |
| <i>Waterloo Register Co. v. Atherton</i> , 9 Cir., 38 F.2d 75 (1930) | 4 |
| <i>Watson v. Allen</i> , D.C. Cir., 254 F.2d 342 (1958)..... | 36 |
| <i>Wende v. Horine</i> , 7 Cir., 225 Fed. 501 (1915).... | 7, 18, 19 |
| <i>Wenzelmann et al., In re</i> , 38 App. D.C. 528, 1912 C.D. 535 | 27 |

TEXTBOOK

| | |
|--------------------------------|----|
| 69 C.J.S. Patents § 78(d)..... | 23 |
|--------------------------------|----|

STATUTES

| | |
|----------------------------|---------------------------------------|
| 28 U.S.C.A. § 1291..... | 1 |
| 35 U.S.C.A. § 101(a)..... | 3 |
| 35 U.S.C.A. § 102..... | 3, 5 |
| 35 U.S.C.A. § 102(b) | 3, 5, 6, 7 |
| 35 U.S.C.A. § 135..... | 4, 26, 29, 30, 31, 32, 34, 35, 36, 42 |
| 35 U.S.C.A. § 146..... | 47 |
| 35 U.S.C.A. § 291..... | 27, 30 |

OTHER AUTHORITIES

| | |
|---|-----|
| Federal Rules of Civil Procedure, Rule 52(b)..... | 13 |
| Patent Office Manual of Patent Examining Proce- dure, § 1101.02(f) | 34 |
| Patent Office Rule 223(d)..... | 45 |
| Webster's Third New International Dictionary..... | 1-2 |

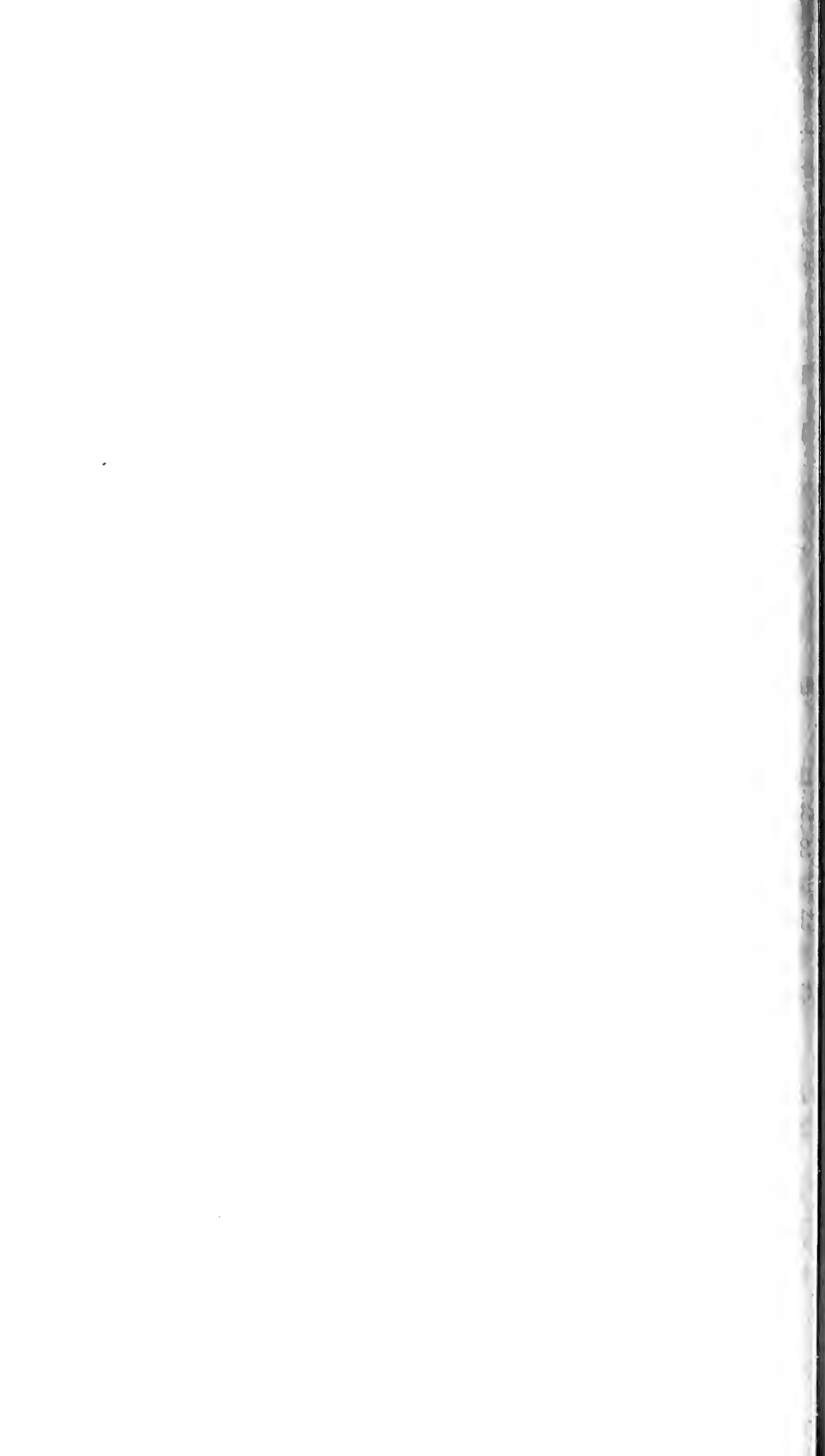

United States Court of Appeals For the Ninth Circuit

AMERIO CONTACT PLATE FREEZERS, INC.,
Appellant,

vs.

BELT-ICE CORPORATION and FRANK W.
KNOWLES, *Appellees.*

No. 18177

APPEAL FROM THE UNITED STATES DISTRICT COURT FOR
THE WESTERN DISTRICT OF WASHINGTON
NORTHERN DIVISION

BRIEF OF APPELLEES

STATEMENT OF JURISDICTION

This is an appeal from a declaratory judgment of the United States District Court for the Western District of Washington. The trial court determined that Knowles patent No. 2,927,443 is valid and has been infringed by appellant. This court has jurisdiction of the appeal under the provisions of 28 U.S.C.A. § 1291.

CLARIFICATION OF APPELLANT'S STATEMENT OF THE CASE

The so-called "mock-up" of a package freezer constructed by Knowles (Amerio Br. 6) was made from scrap lumber and had plates made of plywood (Pl. Ex. 4; Tr. 86-87, 213). Actually, it was a small wooden model, not a "prototype" (Amerio Br. 6 and Tr. 213 and 214) as defined in Webster's Third New Interna-

tional Dictionary as "the first full-scale model of a new type or design of furniture, machinery or vehicle." Examples of a "prototype" given in such definition are a piloted flying model of a new type of airplane, a chair, a tractor engine and a military tank. It was not even a true "mock-up" which, by dictionary definition, is a full-sized representation of the article. Subsequently, Mr. Knowles had shop construction drawings made for a full-size freezer (Tr. 639; Pl. Exs. A5.01 to 5.17) over the period from January 2 to March 28, 1951, ordered materials and supplies for the construction of two such package freezers (Pl. Exs. 7A, 7B, 7C, 7D, 7E and 7F), and ordered special freezing plates for them from Dole Refrigerating Company (Pl. Exs. 10A, 10B).

Appellees, in March or April of 1951 (Tr. 103; Pl. Ex. 11, pp. 68 and 69) undertook to construct at Carmac Shipyards in Seattle the two package freezers. On May 22, 1951, the freezing plates arrived at the Belt-Ice shop (Tr. 105), and work was performed on them on May 23 (Tr. 176). The critical date for public use or sale in this case is May 23, 1951, one year before the filing date of the Knowles patent application. Plates were first installed in a Knowles package freezer on May 25, 1951 (Tr. 177 and 178). Although Knowles' diary entry for June 5, 1951 (Amerio Br. 11) indicates that a verbal purchase agreement was reached on that day and the machines were shipped to the Evergreen Frozen Foods plant at Snohomish on June 19 and June 21, 1951 (Pl. Ex. 45), no written order actually was signed until June 23, 1951 (Defs. Ex. A9.1).

The two machines were built on speculation. The as-

signment of job order No. 645 to those freezers, as shown in Pl. Exs. 29, p. 8, item 9, and Pl. Ex. 35, states that they were for “*stock.*” Mr. Knowles hoped Evergreen could finance the purchase (Tr. 318).

ARGUMENT

Summary of Argument

1. 35 U.S.C.A. § 102 provides as follows:

“A person shall be entitled to a patent unless—

“(a) The invention was known or used by others in this country, or patented or described in a printed publication in this or a foreign country, before the invention thereof by the applicant for patent, or

“(b) The invention was patented or described in a printed publication in this or a foreign country or *in public use or on sale* in this country, more than one year prior to the date of the application for patent in the United States. . .” (Italics supplied)

The word “invention” appearing in subparagraphs (a) and (b) of § 102 is defined in 35 U.S.C.A. § 101 as including a machine or manufacture.

“§ 101. Inventions patentable

“Whoever invents or discovers any new and useful process, machine, manufacture, or composition of matter, or any new and useful improvement thereof, may obtain a patent therefor, subject to the conditions and requirements of this title.”

To be in public use, a machine or manufacture must be complete and operated for its intended purpose in a public or commercial way.

For a machine or manufacture to be “on sale” it

must be complete in its final form, fully operational and ready for use when offered for sale or sold.

Prior to or on May 23, 1951, the critical date here involved, the record shows that appellees did not have available for use or in completed or operational form the package freezer described in Knowles patent No. 2,927,443.

There was no prototype or manufactured sample in existence prior to or on May 23, 1951.

There was no offer for sale or sale of a completed machine containing the invention prior to or on May 23, 1951.

Appellant is estopped by *res judicata* from challenging Knowles' right to make the interference claims under 35 U.S.C.A. § 135.

Appellant misconstrues 35 U.S.C.A. § 135. 35 U.S.C.A. § 135 only requires that the same general subject matter have been claimed within a year after the patent issues.

The Patent Office followed authoritative decisions in ruling that Knowles added claims properly.

Burden of Proof

The burden of proof on an issue of prior public use or sale rests heavily upon the party seeking to show such use. *Paraffine Companies v. McEverlast, Inc.*, 9 Cir., 84 F.2d 335 (1936); *Waterloo Register Co. v. Atherton*, 9 Cir., 38 F.2d 75 (1930); *Covert v. Covert* (Circuit Court, W.D.N.Y.) 106 Fed. 183 (1901). Further, the law requires that the "public use" which invalidates an invention under section 102(b) must be

the "ordinary business use for which the invention was designed." *Chicopee Mfg. Corp. v. Columbus Fiber Mills Co.* (D.C. Ga.) 165 F.Supp. 307 (1958), at pages 322, 323.

Appellant must supply proof of invalidating public use or sale beyond a reasonable doubt in order to invalidate the Knowles patent. Appellant in this case bears a heavy burden because of the acknowledged expertise of the Patent Office. It is the rule of this and other courts that factual determinations by the Patent Office are accorded great weight and such findings must be accepted if they are "consistent with the evidence." A decision by the Patent Office must be considered as controlling as to a particular question of fact in any subsequent suit between the same parties unless the contrary is established by testimony which in character and amount carries thorough conviction. *Safeway Stores, Inc. v. Dunnell*, 9 Cir., 172 F.2d 649 (1949); *Esso Standard Oil Co. v. Sun Oil Co.*, D.C. Cir., 229 F.2d 37 (1956).

The "On Sale" Issue

Appellant cites a number of cases with respect to the issue of sale, but carefully avoids any discussion or analysis of most of those cases. Appellees have set forth below, in summary form, an outline of the law relating to public use or sale under 35 U.S.C.A. § 102.

At the outset, it should be noted particularly that there was no Knowles package freezer in manufactured form, capable of freezing packages, or ready for delivery to any customer, until after May 23, 1951, one year before May 23, 1952, on which date the applica-

tion for Knowles patent No. 2,927,443 was filed. The small wooden model of the Knowles freezer was in existence prior to May 23, 1951, but was made principally of scrap lumber, without necessary metal parts, plates, and freezing components.

The Statutory Concept of "On Sale"

Appellant has attempted to bring the Knowles patent within the prohibition of 35 U.S.C.A. § 102(b) by inferring an "offer to sell" the "invention" at a future time. Appellant tacitly admits there was not and could not have been any offer to sell a completed freezing machine prior to May 23, 1951. Since there was no completed machine in existence prior to May 23, 1951, appellant has sought to come within the statute by alleging an "offer to sell" the "invention" as depicted by the wooden model. It should be pointed out that the invention of the Knowles patent could only be offered for sale as embodied in a full-sized working machine.

As discussed below, the rule is settled that for there to be an offer for sale within the "on sale" provision of 35 U.S.C.A. § 102(b), there must be a completed machine, manufactured in its perfected form, on hand and available for use. There was no such machine on hand and available for use at any time prior to May 23, 1951, and certainly no one would have been interested in purchasing a wooden model.

At page 36 of its brief, appellant cites, but does not discuss, some of the leading cases involving the "on sale" concept. Without unduly lengthening this brief, appellees wish to set forth in summary form the holdings of those and other cases on that point.

Appellant first cites *Wende v. Horine*, 7 Cir., 225 Fed. 501 (1915). The apparatus there involved which was subsequently shown to prospective customers "was not in any sense a mere model or an experimental construction, but, as testified to, it was a 'full-sized, complete, operative apparatus'" (at page 503). Appellant admits at page 31 of its brief that in that case a completed full-sized operative apparatus was what was demonstrated. The court based its holding on that fact. It held:

"... an offer to sell, made to a prospective purchaser after the experimental stage has been passed, the invention reduced to practice, and the apparatus manufactured in its perfected form, is a placing on sale within the statute." (Italics supplied)

Appellant next cites *McCreery Engineering Company v. Massachusetts Fan Company*, 1 Cir., 195 Fed. 498 (1912). In that case there was an offer to construct the apparatus from certain drawings and specifications. On the basis of that fact, the court stated:

"We are of the opinion that proof of a mere contract to construct from plans and to deliver in future a machine or manufacture not proven to have been previously completed, falls short of proof that the machine or invention was 'on sale.' The distinction between an executory contract to construct and to pass title in the future and putting an article 'on sale' is substantial and is not merely one of the 'witty diversities' of the law of sales."

It will be noted that "machine" and "invention" are used synonymously in the above quotation. The district

court relied on *McCreery* in its opinion in favor of Knowles in this case (R. 139).

What constitutes a "sale" within the meaning of the statute was discussed in some detail in the early case of *Campbell v. Mayor, etc., of New York* (Circuit Court, S.D., N.Y.) 36 Fed. 260 (1888), at page 263:

"The statute uses the word 'sale' simply, and refers to the sale as a completed transaction, required to have been fully accomplished at least two years [now one year] prior to the application, in order to defeat the patent. An order for the construction of the engine, accepted, would not make a sale of it. If the terms of the order were such that the construction, as it progressed, was for the city, and the maker merely furnished the labor, and the materials which became the property of the city when used, the city itself would construct the engine, and there would be no purchase of it by, or sale of it to, the city, and nothing, in the view now taken of the effect of construction, to affect the right of the inventor to a patent until there was use of the engine by the city. And if the terms were such that the engine remained all the while the property of the maker as it was being built, a passing of the title afterwards would be necessary to make a sale to the city. This would not be done by merely forwarding the engine. It would be the property of the maker when forwarded, and delivery to and acceptance by the city would be necessary to make it the property of the city. A refusal to accept it might make the city liable for damages, but that would not affect the right to the patent."

Appellant cites, but does not discuss, *Burke Electric Company v. Independent Pneumatic Tool Co.*, 2 Cir., 234 Fed. 93 (1916), in which patented motors were or-

dered more than two years before an application for a patent was filed, but were not delivered and could not have been delivered until a time within the critical two-year period. (The critical period has now been changed from two years to one, incidentally.) The court in *Burke* construed the "on sale" provision of the statute as follows:

"The combination of the words ["not in public use or on sale"] indicates that the sale contemplated is such as creates an opportunity for *present public use*. (Emphasis added) It is a situation quite different from the reduction to practice necessary to sustain anticipation. Judge Learned Hand apparently had this in mind when he held that the completion of the invention, though very important in a competition as to priority, was not important upon the question whether the public was using or given the opportunity of present use of the invention. The provision ought to be construed favorably to patentees. If patented articles are on hand ready to be delivered to any purchaser, they are on sale, whether any of them has been sold or not. But, if they are not, they cannot be said to be on sale within the meaning of the act, though the invention itself has ceased to be experimental and is complete."

The district court relied on the *Burke* decision also in deciding the present case in favor of appellees (R. 139 and 162).

A more recent statement of the rule is set forth in *B. F. Sturtevant Co. v. Massachusetts Hair & Felt Co.*, 1 Cir., 124 F.2d 95 (1941), also cited by the court below as supporting its ruling for appellees (R. 139 and 162). In *Sturtevant*, the court, after adopting the rule of

McCreery and *Burke*, quoted from the leading patent law text, *Walker on Patents*, Deller's Edition, Section 85, that:

“ ‘Where a specimen of an invention is built or made to order, it is not ‘on sale’ till [*sic*] it is completed, delivered, and accepted.’ ”

Appellant next cites, at page 36 of its brief, *Metallizing Engineering Co. v. Kenyon Bearing & Auto Parts Co.*, 2 Cir., 153 F.2d 516 (1946), which it had previously discussed at page 19. The court of appeals in that case accepted the findings of the trial court that the patented process had been *practiced mainly commercially* for more than one year before the filing of the patent application. The question was whether such “use” should be considered to be “public” within the meaning of the statute. The district court concluded that such use was *not* “public” but secret, and relied on the prior case of *Peerless Roll Leaf Co. v. H. Griffin & Sons*, 2 Cir., 29 F.2d 646 (1928), in reaching that conclusion. The *Peerless* case is cited in appellant's brief at page 19. The court in *Metallizing* overruled *Peerless* and held that commercial use did constitute “public use” within the meaning of the statute. In *Peerless*, while the machine had been kept secret, it was used commercially to ornament paper boxes which were shown freely and sold in quantity. Compare the fact that Knowles' wooden model was incapable of freezing food packages for commercial or any use.

In addition to the cases cited above, appellant relies upon *Covert v. Covert* (D.C.N.Y.) 106 Fed. 183 (1901), in which the particular article was a wagon jack which was fully manufactured in its completed form, placed

in stock, and exposed for sale in a hardware store more than two years before the filing of the patent application. The *Covert* case plainly does not support the rule contended for by appellant.

Appellant places considerable reliance upon *Magee v. Coca-Cola Company*, 7 Cir., 232 F.2d 596 (1956). That case involved a beverage dispenser, and at page 600 of the opinion is found the following statement:

“The evidence shows unquestionably that the Magnus Fruit Products Company and its successor, Lyons-Magnus, Inc. had knowledge of, manufactured and offered for sale, sold, publicized and placed in use the model 112-CF dispensers more than two years prior to the filing date of the Magee patent. . . . The machines then being manufactured were fully described in the literature in evidence; witnesses testified that 15 or 20 units were sold to an agency in New York; that the Chism Ice Cream Company of Reno, Nevada, listed as a distributor, bought many of them; that distributors actually shipped them to sheps of the U.S. Navy; that the dispenser was operated by one Simon personally in 1929, and that an offer to sell the device was made to Woolworth and Co.”

In *Magee* also the patented article had been fully manufactured, was available for use and had been sold for longer than the statutory period.

Appellant proposes a novel legal theory for application to the case at bar, at pages 22 and 23 of its brief. It is there stated:

“This offer of sale, in December of 1950 and January of 1951, is clear from this record beyond a peradventure of a doubt. No matter what view is taken of the subsequent sale, the specific offer to

Cedargreen long prior to May 23, 1951 is undeniable. It was an offer that ripened into sale.”

Appellant then cites *Cf. Egbert v. Lippmann*, 104 U.S. 333 (1881). Appellees submit that the citation, even as analogous authority, is too fragile a reed to support appellant’s novel theory.

In *Lippmann*, the article of invention was a corset-steel or stay. One set of corset-steels were fully manufactured and given to a lady to use. She used them for a period longer than the then statutory two-year period. The court held that the use was “public” within the spirit of the statute, stating:

“If an inventor, having made his device, gives or sells it to another, to be used by the donee or vendee, without limitation or restriction, or injunction of secrecy, and it is so used, such use is public, even though the use and knowledge of the use may be confined to one person.”

Appellees believe that the *Lippmann* case in no way supports the theory advocated by appellant, but in fact recognizes the rule that a machine or device must be fully manufactured and used for its intended purpose in order to constitute a “public use.”

In citing certain of the cases discussed above, appellant has failed to mention the recent case of *Trico Products Corporation v. Delman Company* (D.C. Iowa) 199 F.Supp. 231 (1961), which followed the rule of *B. F. Sturtevant v. Massachusetts*, 1 Cir., 124 F.2d 95 (1941), and *Burke Electric Co. v. Independent Pneumatic Tool Co.*, 2 Cir., 234 Fed. 93 (1916), heretofore discussed. *Trico* was also relied upon by the district court in deciding this case in favor of Knowles

(R. 139 and 162). The *Trico* case followed *F. E. Myers & Bro. Co. v. Goulds Pumps* (D.C.N.Y.) 91 F.Supp. 475 (1950), and quoted from it the rule that an article which is not on hand and ready for delivery is not "on sale" within the meaning of the statute, but that an article which is on hand, ready to be delivered to any purchaser, is "on sale" whether or not the article has been sold. The court also quoted the rule from *Burke* that where a specimen of an invention has been built or made to order, the invention is not "on sale" within the meaning of the statute, until that specimen is completed, delivered and accepted.

In the district court, in support of its motion under FRCP Rule 52(b), appellant had discussed *Connecticut Paper Products v. New York Paper Co.* (D.C. Md.) 39 F.Supp. 127 (1941). It has not cited that case on this appeal. In that case an imperfect model of a paper cup dispenser had been prepared and shown to a prospective purchaser. Subsequently there were negotiations looking toward a sale of the cup dispenser. Still later, but more than two years prior to the patent application date, an agreement was reached whereby, after thirty days, the cup dispenser would be supplied to the prospective purchaser, and the dispenser to be supplied was to be in conformity with the demonstrated model. The court found that there was no evidence that any of the dispensers had been completed or actually delivered to the prospective purchaser or to anyone else prior to the critical date. It reviewed a number of the prior cases, cited many referred to heretofore, and stated:

"An agreement to sell, made prior to the statu-

tory period, is not in itself sufficient to invoke the bar of the statute, if the goods were not in fact on hand prior to that period, and therefore could not have been delivered prior to that period.”

The court then quoted from *Burke Electric v. Independent Pneumatic Tool Co.*, 2 Cir., 234 Fed. 93 (1916), as follows:

“ ‘The combination of the words indicates that the sale contemplated is such as creates an opportunity for *present public use.*’ ” (Italics supplied)

The association of the words “public use” and “sale” is also emphasized in the case of *Piet v. United States* (D.C.S.D. Cal.) 176 F.Supp. 576 (1959), modified 283 F.2d 693, cited in appellant’s brief at page 19. In that case the court stated:

“ . . . the sales of the invention by the plaintiffs more than one year prior to the filing of the application for the patent, without a pledge of secrecy and without restrictions or reservation to the plaintiff of any control over the subsequent use of the device, resulted in a ‘public use’ which invalidated the patent. Subsequent conditions imposed on the use, *by others*, either under contract with the Government or by law, did not change the character of the unconditional sale and consequent public use.” (Emphasis the court’s) (Footnote omitted)

The Concept of “Sale” by Sample

Appellant also relies on *Chicopee Manufacturing Corp. v. Columbus Fiber Mills Co.* (D.C. Ga.) 165 F. Supp. 307 (1958). The case is cited at page 33 of appellant’s brief for the principle that an actual sale is not necessary for an article to be “on sale,” but a portion of the court’s opinion, not referred to by appel-

lant, shows that a special factual situation there existed which lends absolutely no support to the theory appellant here attempts to advance. In *Chicopee*, the invention involved woven thermoplastic fabrics having puffed portions containing an ornamental pattern. The fabrics were manufactured and circulated to manufacturers in the automotive industry in the form of samples. The court found that:

“*It was the custom of the textile industry to solicit trade from the automobile manufacturers in Detroit by exhibiting samples of the cloths for which orders are sought.*” (Emphasis added) (page 323)

That *custom in that particular trade* was considered by the court to establish that the fabrics were “on sale” within the meaning of the statute. No comparable *custom* has been shown to exist or established or even suggested in the case at bar.

Another of appellant’s citations at page 35 is *Dittgen v. Racine Paper Goods Co.* (D.C. Wis.) 181 Fed. 394 (1910), in which the particular article was a cigar pocket or pouch. The court determined that the inventor had made and sold many thousands of such pockets in the regular course of his business for more than two years before he applied for a patent. He did not keep the cigar pockets in stock, but the court recognized the *custom in the trade* of making them up only when orders for them were received so that printing and advertising could be placed on them. Orders were taken on the basis of a fully manufactured sample.

In *Trico Products Corporation v. Delman Co.* (D.C. Iowa) 199 F.Supp. 231 (1961), relied upon by the court

below in deciding for Knowles, samples had also been submitted to automobile manufacturers. The following portion of the *Trico* opinion found at page 251 is of interest:

“Application for the Neufeld patent was filed June 7, 1951. A series of letters introduced in evidence revealed that Delman sent samples of this device to Ford, AC Spark Plug Division of General Motors, Studebaker, and the Fisher Body Division of General Motors over a year prior to June 7, 1951. There is, in addition, certain testimony of Neufeld which can be taken to mean that he considered that efforts were being made to sell the device. Defendants take the position that the samples being submitted to the car companies were not being offered for sale but only for testing and trade reaction. In view of the fact that the device was not on hand and ready for delivery, and that it had not been delivered or accepted it is held that the device was not ‘on sale’ within the meaning of the statute, and the patent is not invalid on this ground. This view is supported by the better reasoned cases.”

The court then cites several cases discussed above. Note that no *custom* in the windshield cleaner industry, to which that case related, of *selling by sample* was found, as the court had found to be true of the textile industry in the *Chicopee* case discussed above.

The *Philco* Case Involved Unusual Facts

Appellant places principal reliance upon the recent case of *Philco Corporation v. Admiral Corporation* (D.C. Del.) 199 F.Supp. 797 (1961). The court there held that because certain television sets were shown to

a dealer and orders taken for sets to be delivered subsequently, the sets were placed "on sale" within the meaning of 35 U.S.C.A. § 102(b). The facts there involved, however, were exceptional and not at all comparable to the facts of the present case.

The court in *Philco* first found as a fact that there was a continuing, established and intimate business relationship between Philco and Firestone, the prospective purchaser in that instance. Firestone was a regular and substantial customer of Philco and sold Philco products exclusively in the electronics field. The court also found that because Firestone announced and introduced Philco products at about the same time as Philco, advance information and advance arrangements between Philco and Firestone were an economic necessity. The court further found that it was customary for the Firestone management to visit Philco production centers to view Philco's new line of products two or three months ahead of Philco's announcement of its new product lines. Nor did the court in assessing the history of the established business relationship between Philco and Firestone overlook the fact that in that case Philco had several completely operative devices which were going through final tests.

The parties had finalized the question of price, but quantities had not yet been established. The court found, however, that because of the close business relationship between Philco and Firestone such matters as price and quantity were not particularly determinative in their contract relationships. Philco historically had governed its production in accordance with the quantities specified in certain "releases" and, in fact, had

shipped to Firestone upon an oral request before a purchase order had been received. The court stated at page 815:

“Firestone and Philco wanted both flexibility and reliability, and they achieved this through a relationship which did not depend upon purely legal considerations.”

After concluding that there had been an offering for sale of the patented article prior to the critical statutory date, and grounding this holding on the relationship of the parties, the court then stated:

“The area sought to be governed by these rules . . . encompasses an infinite variety of factual situations which, when viewed in terms of the policies underlying Section 102(b), present an infinite variety of legal problems wholly unsuited to mechanically-applied, technical rules. The ‘in public use or on sale’ rules as applied to the independent craftsman who constructs a product to order, for instance, may lead to an absurd result when applied to an integrated, mass production industry with highly organized merchandising systems.”

The Error in *Philco*

Most important for this court’s consideration, however, is the fact that the district court in *Philco* misread the holdings of *Wende v. Horine*, 7 Cir., 225 Fed. 501 (1915); *Magee v. Coca-Cola Company*, 7 Cir., 232 F.2d 596 (1956), and *Chicopee Mfg. Corp. v. Columbus Fiber Mills Co., Inc.* (D.C. Ga.) 165 F.Supp. 307 (1958), stating:

“In these cases, the fact that the goods sold had to be manufactured subsequently was of no significance.”

The facts of the *Magee* case were, however, that 15 or 20 completed and commercially operable units had been sold to one agency and many units had been sold to a distributor more than two years before the filing date of the patent application. The court in *Magee* reaffirmed its position taken in *Wende v. Horine*, quoting from that case that "the apparatus [must be] manufactured in its perfected form" in order to be considered "on sale." The *Chicopee* case involved a situation where the court found it was "the custom of the textile industry" to solicit trade from automobile manufacturers by exhibiting *samples of completed cloth* with the present ability and desire to fill orders for the same. In *Chicopee* the court distinguished the facts of that case where a *custom* of "sale by sample" had been proven with the facts of *Hutton v. Frank Kreaments Co.*, 3 Cir., 231 Fed. 973 (1916), where sample eye glasses had been "left to show" but were not sold or left for sale or offered for sale, and consequently were not "on sale" under the statute.

Thus it is clear that the district court in *Philco* either misread or misunderstood the holdings of the above cases. In *Wende*, *Magee* and in *Chicopee*, the fact that the goods were fully manufactured, in final form and ready for use was of crucial and determinative significance. Such an oversight by the court in *Philco* cannot be disregarded or lightly dismissed.

Despite the error of the court in *Philco*, that case is essentially compatible with the long line of authority cited above requiring the existence of a fully manufactured operative machine or device in a deliverable state in order for the same to be "on sale." The court noted

that there were handmade models which were fully operational and were being tested for final approval. Showings were made to the Firestone representatives of mock-ups, apparently full size, which represented the design but would not perform electronically. These facts bring the case within the rules set forth above, particularly that line of authority where a *custom in the particular trade* of "sale by display of samples" had been established. The court, however, did put principal emphasis upon the long and intimate business relationship of the parties, the nature of the electronics industry, and the competitive positions of Firestone and Philco in that industry, which factual situation is not present in the case here on appeal.

In contrast to the relationship of Philco and Firestone, is the relationship between Knowles and Evergreen Frozen Foods. Knowles was and is an independent inventor who designed and had built the package freezer here involved. He showed a small wooden model of that freezer to several packers in the frozen food industry to obtain an evaluation of the possible market for such a freezer in the industry. R. O. Cedargreen of Evergreen Frozen Foods expressed interest in the new concept of the freezer as represented by the wooden model. A period of negotiations began with an offer by Knowles (Pl. Ex. 5C), a rejection and counter-offer by Cedargreen (Pl. Ex. 5D), and intermittent verbal discussions. No formal agreement as to financing and purchase of the freezers was reached by May 23, 1951, the critical date, or until at least June 5, 1951, when a verbal understanding apparently was evolved to the satisfaction of both Knowles and Cedargreen.

Even that understanding was not formalized in writing as contemplated by both parties until June 23, 1951 (Defs. Ex. A9.1), after actual delivery of the freezers. At no time was there a close relationship between the parties, although Knowles had done some work for Cedargreen on earlier occasions. Further, there was no full-size, fully completed operative prototype of the freezer, or even a full scale mock-up of the freezer, in existence until considerably after May 23, 1951, when the first freezer was manufactured. Prior to that time there existed only the small wooden model made of scrap lumber which was incapable of operating as a freezer, shop drawings of an operating freezer, and two partially assembled and partially shop-tested full-size freezers in course of being constructed but still uncompleted. These first two freezers were built on speculation and for stock.

Knowles hoped that he could sell those two freezers to Evergreen Frozen Foods which had shown interest in them, but he had no firm purchase order until after the machines had been completed in June of 1951. Neither Knowles nor Cedargreen would have been able to succeed in an action for breach of contract on the basis of their preliminary negotiations involving the freezers up to May 23, 1951, the critical date. The trial court expressly found that Belt-Ice Corporation solicited an order for two freezers at a proposed price of \$11,400.00 on January 30, 1951, but that that offer was not accepted (Finding of Fact 20, R. 82). The court further found that the written order for the two freezers was dated June 23, 1951, less than one year before the filing date of the Knowles patent application on

May 23, 1952. The court further found that there is "no evidence of a definite offer by one party accepted by or acceptable to the other party prior to that date" (Finding of Fact 21, R. 82).

Appellant's brief seeks to ignore the principal fact that there was no completed, fully operational machine ready to be delivered at any time as early as May 23, 1951, one year prior to Knowles' application for a patent. Appellant also seeks to ignore the fact that no order for any freezer was given until June of 1951, and that prior to that time only sporadic, exploratory and inconclusive negotiations had occurred between the parties. This situation is not surprising, for Knowles had no machine completed and ready for sale, and Cedargreen had neither the ability nor the inclination to finance the construction of a freezer on speculation. There was no construction contract. Knowles undertook the risk of building the freezers for "stock" without any obligation on the part of Evergreen to take delivery of them.

In an attempt to avoid such facts, appellant has put forth a theory of "competitive use," terminology which was used in the quotation from *Philco Corporation v. Admiral Corporation* appearing at pages 20 and 21 of appellant's brief. As has been discussed above, the *Philco* case involved a unique factual situation which was far different from the facts of this case. Appellant does not really explain its understanding of "competitive use," nor does it clearly apply that term to the facts of the present case. It mentions "competitive sales effort," but there is no proof of compet-

ing sales in this case. At page 21 of its brief, appellant states that

“A restatement of this *underlying policy* is found in *Watson v. Allen* (C.A.D.C., 1958) 254 F. (2d) 342.” (Emphasis added)

Appellees have found no reference in the *Watson* case to “competitive use” or “competitive sales effort” and the court there affirmed the holding of the lower court rejecting the decision of the Patent Office “that the invention had been in non-experimental public use” for more than one year before the filing date of the patent application.

Appellant has also attempted to avoid the fact that Knowles had no completed freezer available for delivery until after the critical date of May 23, 1951, by claiming that although the patented device was not on sale, the “invention” was on sale because the small wooden model contained the invention. Certainly no prospective purchaser wanted to buy that wooden model, and since an “invention” has no existence apart from its embodiment in a machine, the freezer was not “on sale” within the critical period. The inchoate right to protect the invention by patent was not on sale.

Finally, appellant ignores the great number of cases setting forth the rule followed by the trial court in this case, from which it selected properly representative cases to support its decision. A concise summary of the case authority may be found, incidentally, in 69 C.J.S. Patents, § 78(d). Appellant has placed principal emphasis upon a single district court case, *Philco Corporation v. Admiral Corporation* (D.C. Del.) 199 F.Supp. 797 (1961), the holding of which rests upon

a business relationship and facts wholly absent from the case at bar.

A Recent Decision

An interesting recent case is *Browning Manufacturing Co. v. Bros, Incorporated* (D.C. Minn.) 134 USPQ 231, — F.Supp. — (1962). In *Browning*, the patented article was a pneumatic roller compactor, used in road building and grading. The machine in completed form was displayed by the American Road Builders Association at a special show in Chicago in July of 1948, more than one year before the application filing date. The purpose of the show was to display road machinery to the trade and to the public. The court found that the exhibit of the roller compactor was visited by a substantial number of people who attended the show, and that a printed pamphlet telling about the roller compactor was freely distributed to patrons at the show. The pamphlet distributed quoted a price of “\$12,500 f.o.b. Minneapolis, Minn.”

Browning Manufacturing Company sought a declaratory judgment that the patent was invalid and not infringed. Plaintiffs argued that the roller compactor was “on sale” for more than one year prior to the date of the application for the patent, relying principally on the fact that the price of the machine was stated in the pamphlet distributed to the public. In addition, plaintiffs argued that the machine had been offered to the United States Army Corps of Engineers to undergo tests, and that if the tests were satisfactory, the Corps of Engineers could regard the transaction as an offer of sale.

The court found that there was convincing testimony that the inventor did not intend to offer the roller compactor for sale until it had been thoroughly tested. The following statement from the opinion is instructive:

“It is true that an actual sale is not required under the statute, in that the law provides that if the device was placed on sale more than one year prior to the date of the application for the patent, the patentee would not be entitled to a patent. The Court concludes, however, that the plaintiffs have not sustained the burden of proof in establishing that the machine was ‘on sale.’ Granted that the exhibition of the machine at the Road Show, with distribution of the pamphlet which states that the price of the roller was \$12,500, tends to lend credence to plaintiffs’ contentions in this regard. A sound analysis of the entire testimony, however, would indicate that Bros’s activities upon which the plaintiffs rely were directed at sounding out the industry’s reaction to the machine and indicated the price at which it would be sold after the company had fully tested the machine, and if the tests proved satisfactory then the company would be ready thereafter to place the machine on the market for sale at the proposed price.

“Plaintiffs further contend that while the roller was on display at the Road Show it was in ‘public use’ within the meaning of Section 102(b), Title 35, U.S.C. Undoubtedly, the machine was at the exposition for the purpose of public examination. However, it did not move from its location at the defendant’s booth, and as the Court stated in its order denying the motion for summary judgment,

...

“ * * * It carried no ballast and no tests were

performed upon it or the ground surfaces upon which it rested. It does not appear that the machine was used for the purpose for which it was invented and manufactured. It never was loaded and operated, either publicly or commercially, or for that matter, either privately or experimentally.

***''

Appellees believe that the *Browning* decision is in full accord with the authority appellees have cited above and upon which the district court relied for its decision in this matter.

Appellant Is Estopped by *Res Judicata* from Challenging Knowles' Right to Make the Interference Claims Under 35 USCA § 135

At pages 42 to 45 of its brief, appellant discusses "the issue raised by 35 USC § 135," which relates to questions 3 and 4 on page 13 of appellant's brief, and perhaps specification of error 4, 5 and 6 on page 14 of that brief. That issue originated in Patent Office Interference No. 88174 between Mackenzie Patent No. 2,697,920 and Knowles patent application Serial No. 289,638 which resulted in the Knowles patent here in suit. The decision of the Patent Office Board of Patent Interferences awarding priority to Knowles was made the subject of Civil Action No. 5092 in the court below between Amerio Contact Plate Freezers, Inc. and Frank W. Knowles and Belt-Ice Corporation. The action was instituted by appellant, Amerio. It is pointed out both in the footnote at the bottom of page 2 of appellant's brief and at the bottom of page 38 of that brief that the decision in favor of appellees in that case was not appealed and consequently has become final in

favor of Knowles and Belt-Ice Corporation, so that likewise the decision of the Board of Patent Interferences rendered in favor of Knowles in Patent Office Interference No. 88174 has become final.

In the present case, which was C.A. 5171 in the trial court, Amerio also asserted a cause of action on the ground of interfering *patents* under 35 U.S.C.A. § 291. Although on its face that statute affords relief in the case of interfering patents it is believed that that statute was not intended to allow the same issues to be re-litigated by the same parties when a final decision has been rendered previously on such issues and between such parties. In this instance, the precise question involved was an issue in the proceeding of interference No. 88174 in the Patent Office, and subsequently in C.A. 5092 between the parties in the District Court for the Western District of Washington, the judgment in which has now become final.

The situation in this instance therefore is somewhat similar to that in the case of *In re Wenzelmann et al.*, 38 App. D.C. 528, 1912 C.D. 535, in which a final judgment had been entered awarding priority in an interference to Gilman as against Wenzelmann et al. Thereafter, public use proceedings showed that the claims should be refused to Gilman, but the court held that that did not revive any right in Wenzelmann et al. to the claims, stating,

“the proceedings touching public use cannot affect the judgment of priority in the interference proceeding. That judgment is *res adjudicata* against appellants, and to sustain their present contention would be equivalent to a retrial of the

question of priority or a second interference, when they have been foreclosed by a final judgment in the first.”

Thus, in the present case there has been a final judgment in C.A. 5092 and whatever the outcome might be as to appellant’s contention as to public use or sale, the issues settled by final decree in the interference proceeding and C.A. 5092 cannot properly be relitigated on this appeal.

A situation somewhat similar to that of the present case was also considered in the recent decision of *Coakwell v. United States*, Ct. Cl., 292 F.2d 918 (1961). In that case, as here, patent infringement was the issue between two parties whose patent applications had previously been in interference, or at least, the United States, which was the defendant, had had an interest in the other application in interference. In that suit for patent infringement, the court stated:

“defendant relies primarily on the alleged knowledge and disclosures of Dr. Ferwerda prior to plaintiff’s application. * * * Plaintiff’s application was still pending when Ferwerda’s application was filed, and the Patent Office instituted interference proceedings between plaintiff, Ferwerda, and others, to determine who was the first inventor.”

The Board of Patent Interference Examiners awarded priority to Coakwell, the plaintiff, and Ferwerda filed a complaint in the district court to set aside the decision of the Patent Office in the interference, just as Amerio brought suit in the district court to set aside the interference decision of the Patent Office in C.A. 5092, which was not appealed. In the *Coakwell* case

the complaint was filed too late and was dismissed, and on appeal the dismissal was upheld so that

“the action of the Patent Office, holding that plaintiff was the first inventor, was final.”

Correspondingly, Amerio, having failed to appeal in C.A. 5092, is bound by the determination of the Patent Office that Knowles was the first inventor.

The present action, by virtue of appellees' counterclaim, is essentially a patent infringement action or, from appellant's point of view, an action for declaratory judgment as to the validity of the Knowles patent. In the *Coakwell* case the defendant challenged the patent on the ground of prior knowledge, because a patent was not issued to Dr. Ferwerda. In the case at bar, Amerio challenged the Knowles patent on the ground of conflicting patents, because a patent had been issued to Mackenzie. It is submitted, however, that in the portion of the appeal based on Knowles' alleged failure to comply with 35 U.S.C.A. § 135 one aspect of the Patent Office interference is sought to be relitigated by Amerio. Under these circumstances the pronouncement of the court in the *Coakwell* case, quoted below, is pertinent.

“It is obvious that a decree of the District Court upholding the action of the Patent Office, affirmed on appeal, would be a final adjudication of the question and would be *res adjudicata* in all other courts, and defendant would not be heard to say in this court that plaintiff was not the first inventor. Where the losing party fails to effectively review the Patent Office action in one of the courts and it becomes final, it is equally binding on the parties. It has the same finality as the judgment of either of the courts would have had if one of them had

reviewed it. *Morgan v. Daniels*, 153 U.S. 120, 14 S.Ct. 772, 38 L.Ed. 657; see also *Radio Corporation of America, et al. v. Radio Engineering Laboratories, Inc.*, 293 U.S. 1, 54 S.Ct. 752, 78 L.Ed. 1453.”

It is respectfully submitted that as far as *all issues of the interference* are concerned the decision of the Patent Office Board of Interferences is final by reason of the finality of the decision in C.A. 5092, from which no appeal was taken by Amerio.

It may be said of Amerio in the language of the *Coakwell* decision that,

“it has had ‘its day in court.’ It had the opportunity to present before the Patent Office and the District Court all the facts and advance all the arguments presented here. It is this opportunity that is the basis of the rule of *res adjudicata*. We think it should be applied here. Defendant should not be permitted to relitigate an issue already litigated and finally decided.”

It is believed that the interfering patent statute, 35 U.S.C.A. § 291, was intended to afford a remedy in court in instances in which conflicting patents have been issued *without the opportunity* of an interference contest being afforded in the Patent Office for some reason. Where such an opportunity was afforded and the decision has become final, such as in this instance on the issue of Knowles’ right to make the counts in the interference under 35 U.S.C.A. § 135, it is believed that the non-appealing party, Amerio in this case, is estopped from relitigating this issue here by the doctrine of *res judicata*.

Appellant Misconstrues 35 USCA § 135

If the court should decide to give consideration to the contention of Amerio that,

“Claims 3, 6, 7 and 10 of the Mackenzie Patent were wrongfully awarded to the Knowles patent” (Amerio Br. p. 45),

the following chronology should be noted:

February 25, 1952—Mackenzie United States Patent application Serial No. 273,197 filed

May 23, 1952— Knowles United States patent application Serial No. 289,638 filed

October 15, 1952— Examiner Keaveney gave first action on Mackenzie application

January 22, 1953— Examiner Keaveney gave first action on Knowles application

October 23, 1953— Examiner Keaveney gave second action on Mackenzie application

February 4, 1954— Examiner Keaveney gave second action on Knowles application

May 6, 1954— Examiner Keaveney allowed Mackenzie application

December 8, 1954— Mackenzie patent issued

July 6, 1955— Examiner Yudkoff gave third action on Knowles application *without citing Mackenzie patent*

January 4, 1956— Knowles application amendment filed

- February 14, 1956—Examiner Yudkoff gave fourth action on Knowles application for the first time citing the Mackenzie patent stating “the patent to Mackenzie has been cited of interest,” and finally rejected the Knowles application
- March 23, 1956— Claims substantially like Mackenzie claims were added to Knowles application with an affidavit under Patent Office Rule 131, antedating the Mackenzie patent.
- April 10, 1956— Action by Examiner Yudkoff requiring Knowles to copy claims of Mackenzie patent by June 1,
- May 11, 1956— Claims patterned after Mackenzie claims revised slightly.
- June 13, 1956— Examiner Yudkoff notified Knowles an interference was being declared between Knowles and Mackenzie
- August 7, 1956— Interference declared

The foregoing information is readily available from a study of the Knowles patent file, plaintiff’s Exhibit 28, and the Mackenzie patent file, defendant’s Exhibit A17.

The statute, 35 U.S.C.A. § 135, to which appellant’s brief refers at page 42, states :

“Whenever an application is made for a patent which, in the opinion of the Commissioner, would interfere with any pending application, or with any unexpired patent, he shall give notice thereof to the applicants, or applicant and patentee, as the case may be * * *.”

It is evident from the first sentence of that statute that a person who has filed an application for patent in the Patent Office cannot declare an interference. The statute specifically provides that *the Commissioner of Patents* must give notice of the interference situation. It is believed to be clear, from the history stated above, that Examiner Keaveney failed to give notice of the interfering character of the Knowles and Mackenzie patent applications *prior to the issue of the Mackenzie patent*, and it is further evident that Examiner Yudkoff in giving the Patent Office action of July 6, 1955 failed to notify Knowles of the Mackenzie patent which had issued on December 28, 1954. Although it is true that Knowles can be said to have had "constructive" notice of the patent issue, such a statement is simply a fiction, just as one is presumed to know all of the law. As a practical matter, it would have been impossible for anyone to have known of the 2,697,920 patents, including the Mackenzie patent.

Appellant states at page 43 of its brief that,

"The patent law explicitly requires that anybody * * * must take, or have taken, action which will lead to the declaration of patent interference proceedings 'prior to one year from the date on which the patent (to such other person) was granted.' "

The apparent inference as to such required action is stated in the previous paragraph as follows:

"It was not until March 23, 1956 that Knowles added claims 25, 26, 27 and 28 and 29 to his pending application. These claims for the first time defined subject matter which conformed closely to

the Mackenzie patent claims 3, 6, 7, 10 and 12, respectively.”

It therefore appears that Amerio’s position is that Knowles *must have added* claims *substantially copied* from the Mackenzie patent

“ ‘prior to one year from the date on which the patent (to such other person) was granted.’ ”

Such an assertion is an erroneous interpretation of 35 U.S.C.A. § 135.

35 USCA § 135 Only Requires that the Same General Subject Matter Have Been Claimed Within a Year After Patent Issues

As has been discussed above, the first sentence of 35 U.S.C.A. § 135 relates to initiation of an interference proceeding. The portion of 35 U.S.C.A. § 135 quoted by appellant at the bottom of page 43 and top of page 44 of its brief is the second paragraph of the statute. That paragraph is quoted in the Patent Office Manual of Patent Examining Procedure at Section 1101.02(f) and is then interpreted as follows:

“ ‘A claim which is the same as, or for the same or substantially the same subject matter as, a claim of an issued patent may not be made in any application unless such a claim is made prior to one year from the date on which the patent was granted.’ ”

“It should be noted that an applicant is permitted to copy a patent claim outside the year period if he has been claiming substantially the same subject matter within the year limit.”

To support that directive to the Patent Office Examiners, cases cited by the Court of Customs and Patent Appeals are cited, the most recent decision being *Sta-*

lego et al. v. Heymes et al., C.C.P.A., 263 F.2d 334 (1959), which held that *Heymes et al.* were continually claiming substantially the subject matter of the counts during the time specified by 35 U.S.C.A. § 135, stating

“It is not contended that Heymes et al., presented the *actual* counts in issue until more than one year after the Stalego et al., patent issued, thus the sole question here is whether, within one year after such issuance, they were asserting claims ‘for the same or substantially the same subject matter as’ the counts. * * * The question as to what is meant by ‘substantially the same subject matter,’ as used in 35 U.S.C. 135, and in prior court decisions on which that section is based, beginning with *Chapman v. Beede*, 54 App. D.C. 209, 296 F. 956, has been frequently considered by this court, and a number of decisions bearing on it are cited and discussed in *Rieser v. Williams, supra.*”

The court in *Rieser v. Williams*, C.C.P.A., 255 F.2d 419 (1958), stated:

“It is not disputed that Williams failed to present the actual claims here in issue in his application until more than a year after they appeared in Rieser’s patent. The Board of Patent Interferences held, however, that an estoppel under 35 U.S.C. 135 did not exist for the reason that allowed claim 6 of the Williams application, which was included therein as filed, defines substantially the same subject matter as the interference counts. * * * It is apparent that Williams’ claim 6 is broader than the counts, but the board found that the additional limitations defined by the counts were of no patentable significance. * * * The rule that every limitation of an interference count must be considered material, which rule is applied in de-

termining the right to make the count and priority of invention, is not controlling on the question of estoppel under 35 U.S.C. 135. In the latter situation, the question as to the materiality of limitations is to be considered on its merits, and limitations found to be immaterial may be disregarded.”

Thus the Court of Customs and Patent Appeals, which is the court to which direct appeals are taken from the Patent Office, by the above-cited decisions, has refuted the interpretation of the statute sought by Amerio that the *interference claims themselves* must have been copied by Knowles *within one year* after issue of the Mackenzie patent.

The special character of the Court of Customs and Patent Appeals adds great weight to its holdings in such cases. As the Court of Appeals for the District of Columbia stated in *Watson v. Allen*, D.C. Cir., 254 F. 2d 342 (1958) :

“We recognize the special competence of that court to deal with matters relating to patents and as to technical or highly specialized patent matters, we would accord substantial weight to its views.”

The Patent Office Followed Authoritative Decisions in Ruling that Knowles Added Claims Properly

The manner in which appellant presents the alleged “issue raised by 35 U.S.C. § 135,” beginning at page 42 of its brief, is rather peculiar in that nothing is said about that matter having been considered by the Patent Office during the course of the Knowles-Mackenzie interference, and no decisions are cited. The reader might almost be expected to draw the inference that that was an issue which had been overlooked by the Patent Office,

and perhaps even by the district court, and was now being presented for the first time. To the contrary, the contention that Knowles was not entitled to include claims 25, 26, 27, 28 and 29 in his patent application, and subsequently in his patent, has been urged by Mackenzie and Amerio throughout the prosecution of the Knowles-Mackenzie interference and the finally decided suit, C.A. 5092, *Amerio v. Knowles*.

The propriety of Knowles making the claims in question is supported by the decision of *Rieser v. Williams*, C.C.P.A., 255 F.2d 419 (1958), discussed above. In its decision in the interference awarding priority of these claims to Knowles, the Patent Office Board of Patent Interferences stated:

“On the second question in issue, that of estoppel under 35 U.S.C. 135 on whether or not Knowles had claimed substantially the same invention at some time up to within a year of the grant of the Mackenzie patent we consider that the Primary Examiner arrived at the correct conclusion in holding Knowles not to be estopped. * * * As explained in *Rieser v. Williams* 733 O.G. 572, 118 U.S.P.Q. 96 every limitation in the count claim of the patent is material as regards right to make or priority, but is not material as regards claiming by the applicant before the lapse of the statutory year unless there is a difference in the limitation that is inventive or critical to patentability. * * * The party Knowles accordingly is held not barred by estoppel under 35 U.S.C. 135 * * *.”

Earlier, during the motion period, Mackenzie had raised the same objection and, after considering various claims which had been present in the Knowles application prior to the expiration of a year following issue of

the Mackenzie patent, the Primary Examiner stated in his decision on Mackenzie's motion to dissolve:

“The language in the claims of the Knowles application need not be presented in a single claim to conform with the requirement of 35 U.S.C. 135. The code is satisfied if applicant claimed the subject matter within the critical year in any of his claims, *Thompson v. Hamilton*, 1946 C D 70; 585 O.G. 177, 68 U.S.P.Q. 161.”

The court in *Thompson v. Hamilton*, C.C.P.A., 152 F. 2d 994 (1946), considered the contention of the plaintiff that the language of 35 U.S.C.A. § 135, quoted above, that “unless such a claim is made prior to one year,” required that a *single* claim be presented in the application within such year. In that case it was stated:

“No one contends that within this period of one year Hamilton made a claim ‘which is the same as’ a claim * * * of the Thompson patent.”

Similarly, Knowles does not dispute the statement at page 43 of appellant's brief that claims 25, 26, 27, 28 and 29 added by Knowles

“for the first time define subject matter which *conformed closely* to the MacKenzie patent claims 3, 6, 7, 10 and 12, respectively”.

That, however, is not the issue.

As the court stated in the *Thompson* case:

“We call particular attention to the emphasis placed upon the indefinite article ‘a’ in the first paragraph of the above quotation because of the contention of counsel for appellant before us as to the interpretation of the rule which contention, in substance, is:

“(1) That Hamilton may not make count 1 be-

cause he did not present, within one year after September 16, 1941, in just one claim, a claim embracing all the features which rendered the count patentable.

“(2) That Hamilton may not make count 2 because he did not present, within one year after September 16, 1941, in just one claim, a claim embracing all the features which rendered that count patentable.

“In other words, the contention of counsel for appellant, as we understand it, is, in effect, that the indefinite article ‘a’ embraced in the rule should be interpreted as meaning ‘one’.

“It is obvious that the construction for which appellant contends would create an anomalous situation in cases such as that under consideration.”

How could it be expected that one party would use language “conforming closely” to the language used in the claim of another party *without ever having seen that claim*? Obviously, the practical inquiry is a comparison of the subject matter encompassed by the claims *as a whole* in one application versus the subject matter encompassed by the claims *as a whole* in the issued patent. The court in the *Thompson* case then quoted with approval from the decision of the Patent Office Board of Interferences, as follows:

“An examination of these five claims clearly shows that each feature of the counts had been covered by claim. * * * While it is true that the exact terminology of the counts in issue was not found in the Hamilton application prior to the year period, this is of no consequence as the rule does not require him to make the *identical claims* of the patent

during this period; all that is required is that he shall be urging claims *covering the matter* which is claimed in the patent before the critical period has terminated.

“The objects of the invention of the two parties are the same and substantially the same results are obtained with substantially the same mechanism. The difference is more in the form of expression than in the inventive subject matter covered.”
(Italics supplied)

Thus, the contention of Thompson in the *Thompson* case was precisely the same as that of Mackenzie in the Knowles-Mackenzie interference, and of Amerio here, namely, that *substantially identical* claims had not been added to the Knowles application within one year after issue of the Mackenzie patent. The *Thompson* case follows the rule of reason that the consideration should be as to whether the subject matter being claimed generally was the same, and that is the rule established by various decisions of the Court of Customs and Patent Appeals; that is the rule followed generally by the Patent Office, and *that is the rule which was followed by the Primary Examiner in his decision on Mackenzie's motion to dissolve the Knowles-Mackenzie interference and by the Patent Office Board of Interferences in its final decision in the Knowles-Mackenzie interference.*

The Primary Examiner in his decision on the Mackenzie motion to dissolve also considered the case of *Cryns v. Musher*, C.C.P.A., 161 F.2d 217 (1947), which followed and confirmed the rule established by *Thompson v. Hamilton*. In the later case of *In re Schutte*, C.C.P.A., 244 F.2d 323 (1957), the Court of Customs

and Patent Appeals again considered the statute, and in holding that the applicant could properly make the claim of the interference stated:

“The claims of the earlier application, as we have indicated, are to be interpreted on the basis of a specification which is substantially the same as that of the application at bar. While they are cast in a form quite different from claim 1 copied from Weinrich and use different terminology, it is clear to us that it is the same invention in substance that is being claimed. * * * We therefore hold that appellant was at least claiming ‘substantially the same subject matter, as called for by Sec. 135,’ even before the Weinrich patent issued and is therefore not estopped to make claim 1.”

Appellant does not contend that the Knowles application did not claim substantially the same subject matter as was claimed in the Mackenzie patent within one year from the date of its issue. In the case of *In re Tanke et al.*, C.C.P.A., 213 F.2d 551 (1954), the Court of Customs and Patent Appeals considered

“whether appellants are estopped, as the examiner and board held, to amend their application by the incorporation of the rejected claims, * * * the appealed claims were made 14 months after the date on which the patent to Strandlund was granted and two months after the period of one year had elapsed as proscribed by the statute. However, as noted in appellants’ brief, ‘The application resulting in Strandlund patent 2,483,565 was copending (for several years) in the same Patent Office Examining Division with applicants’ application. * * * The import of the argument urged by appellants before the tribunals of the Patent Office, as well as here, was that claims 34 through 48 were the same as, or

for the same or substantially the same subject matter as, that defined by appellants' original claims 6 and 14; and that such claims, which were under diligent prosecution by appellants during the critical period, came within the recognized exception defined by the statute, citing *Jenks v. Knight*, 24 C.C.P.A. (Patents) 1227, 90 F.(2d) 654, 33 USPQ 601; *In re Lowry*, 25 C.C.P.A. (Patents) 829, 93 F.(2d) 909, 36 USPQ 254; *Thompson v. Hamilton*, 33 C.C.P.A. (Patents) 732, 152 F.(2d) 994, 68 USPQ 161; *Cryns v. Musher*, 34 C.C.P.A. (Patents) 963, 161 F.(2d) 217, 73 USPQ 290."

Apparently it is the position of Amerio that this court should ignore the salutary rule so firmly established by repeated decisions of the Court of Customs and Patents Appeals, whose decision the Patent Office is bound to follow. It is strange, however, that appellant's brief does not give this court the benefit of any of those decisions which have been rendered by the Court of Customs and Patent Appeals and contend, if that is the position of Amerio, that such decisions of the Court of Customs and Patent Appeals are improper and erroneous.

A similar technique was followed by Amerio in its presentation to the district court. Instead of taking the position that it disagreed with the interpretation of 35 U.S.C.A. § 135 and its application by the Court of Customs and Patent Appeals in the various decisions referred to above, Amerio cited only the district court case of *Vinco Corporation v. Wickman* (D.C. Mich.) 193 F.Supp. 516 (1959), which also apparently did not give consideration to any of the cases decided by the Court of Customs and Patent Appeals discussed above.

Moreover, the *Vinco* case is self-impeaching. In that case the court stated:

“It is the opinion of this Court that Section 135, like the statute implementing the International Treaty, means exactly what it says.”

The court then *promptly misquotes* the statute, stating

“That is, the interference must be created within one year from the time the patent interfered with is issued.”

That, if course, is *not* what the statute says, for, as has been pointed out above, the applicant has no control over creation of an interference, but such interference must be instituted by the *Commissioner of Patents*. Neither does the statute require that the precise claims of the patent must have been copied within one year, or even that claims *conforming closely* in language must have been included, as Amerio contends at page 43 of its brief. It is sufficient that “substantially the same subject matter” be claimed.

“While the language of the involved counts and that of the cancelled and allowed claims differs somewhat, we are not convinced that the tribunals of the Patent Office were in error in holding that all of said claims were substantially for the same invention. It seems to us that the difference between them is more in the form of expression than in the inventive subject matter covered.” *Jenks v. Knight*, C.C.P.A., 90 F.2d 654 (1937).

It is *not* necessary that the claims be

“identical to, or substantially the same as,”

the claims of the patent as appellant contends in its brief at page 44, line 9. Consequently, 35 U.S.C.A. § 135 is *not*

“a bar to the appropriate entry by Knowles of his claims 25-29 on March 23, 1956 because he is by the statute estopped to do so.” (Appellant brief, p. 44, middle)

Even if the court should give consideration to this contention of Amerio, which it is believed it should not because Amerio is estopped by the doctrine of *res judicata*, as discussed above, it is clear that this contention of Amerio is erroneous and should be rejected by this court.

Erroneous and Irrelevant Matter in Appellant's Brief

Various statements have been made in appellant's brief which are erroneous, or appear to be immaterial, as to the issues in this case, but in the event that some reliance might be placed on them by appellant, it is believed that the following comments should be considered.

At the middle of page 3 appellant's brief states:

“The patent contains a claimed priority date of May 10, 1951 based upon a British application.”

That statement is reminiscent of that which appeared in the Amerio trial brief at the top of page 7, that

“Mackenzie's application contained a claim of priority based on the British application made on May 10, 1951. This claim of priority was clearly set forth on the face of the Mackenzie patent as finally issued.”

A similar statement was made on page 11, page 43 and page 65 of the Amerio trial brief. Yet, at the bottom of page 42 of that brief appears the statement:

“Mackenzie has always maintained that it was

entitled to no date prior to that of its filing on February 28, 1952.”

It was thought that this question had been resolved completely during the trial by the statement appearing on page 653 of the record. When counsel for appellees raised the point, counsel for Amerio stated:

“We originally thought we were entitled to that date, and we find we are not.

“THE COURT: Which date?”

“MR. PATTEN: May 10th. We are not entitled under the treaty, to go back and claim that date.”

Yet here in the brief on appeal the statement is made as to the “priority date of May 10, 1951, based upon a British application.” For whatever purpose that statement may have been made it is certainly misleading, because although it is true that that date appears on the patent, Amerio has admitted that Mackenzie is not entitled to rely on it and it therefore constitutes a misrepresentation. Why was this misrepresentation asserted at the middle of page 3 of appellant’s brief without explanation?

On page 5 of appellant’s brief, reference is made to “affidavits” of Knowles which were filed in the Patent Office. Those so-called “affidavits” were simply the preliminary statements filed in accordance with Patent Office Rule 215, which states that

“The preliminary statement must be signed and sworn to by the inventor.”

But Patent Office Rule 223(d) also states:

“The preliminary statement can in no case be used as evidence in behalf of the party making it.”

Such "affidavit" is therefore simply a pleading. Moreover, it is an unusual type of pleading in that it serves as a limitation on proof in an interference. Consequently, the statements made in such preliminary statements have no bearing on the *proof of facts* established by the interference testimony. Why, then, are those preliminary statements criticized on page 5 of appellant's brief without further explanation?

At the bottom of page 12 and top of page 13, question 2 asks whether claims were "disclosed in the Knowles application." There appears to be no discussion of that question in the brief and no basis given for the question. Why is that question raised when the basis for it is not set forth in the brief? Since no issue on that point is presented, presumably that question has been abandoned as an issue by appellant.

The third specification of error at the bottom of page 13 of appellant's brief makes reference to Finding of Fact No. 30 as being in error, but there appears to be no further discussion of that point in the brief, so that presumably that specification of error has been abandoned by Amerio and requires no further comment.

Specifications of error Nos. 4, 5 and 6, as well as No. 3, have no place in this appeal because they relate directly to Interference No. 88174, reviewed in Civil Action No. 5092, which has become final because no appeal was taken from it, as has been discussed above. Consequently, because of the finality of the court's decision, the decision of the Patent Office Board of Patent Interferences in the interference also has become final so that it constitutes a bar to relitigation of those issues in C.A. 5171 or on this appeal.

Specification of error No. 8, at the bottom of page 14 of appellant's brief, asserts that the court's conclusion of law No. 10 as to infringement of claims of the Knowles patent by the Amerio freezer, is in error, but there is no apparent explanation elsewhere in the brief as to the alleged nature of such error. In the Pretrial Order (R. 183), admitted fact 5 states that claims 13, 14, 15, 16 and 17 of the Knowles patent apply to the Amerio freezers and admitted fact 7 (R. 184) concedes that the principal ground on which noninfringement is contended is that the Knowles patent is asserted to be invalid. It is believed that there should have been some explanation in appellant's brief of this specification of error along these lines. These same comments apply to specification of error 9(a).

The reference to the Knowles patent which issued March 8, 1960, set forth at the bottom of page 21 of appellant's brief, is immaterial. Its issue was delayed because, as has been discussed above, the Patent Office failed to institute an interference between the Mackenzie application and the Knowles application while both applications were pending in the Patent Office, as should have been done. The issue of the patent was further delayed by Mackenzie filing a suit in the District of Columbia under 35 U.S.C.A. § 146 to review the decision of the Patent Office. Such action should have been brought in the State of Washington. The Patent Office delayed the issue of the patent until the matter of jurisdiction was settled, but those facts are not material to the issues presented on this appeal.

At the bottom of page 37 and top of page 38, appellant again refers to the "affidavits" filed by Knowles in

the Patent Office which, as explained above, were simply the interference preliminary statement pleadings in which an error was discovered, thus necessitating a revised preliminary statement. It certainly is not unusual for an amended sworn complaint to be filed to correct allegations in an earlier complaint, and in neither case is the complaint considered to be "evidence" in the case any more than preliminary statements are accepted as evidence in an interference. All of the discussion on page 38 of appellant's brief is therefore immaterial and irrelevant to the issues here on appeal and appears to have been inserted simply to establish prejudice in the mind of the court based on subject matter extraneous to this case and to this appeal.

Why appellant, at the bottom of page 38 and top of page 39, should make reference to C. A. No. 5092 is not clear, but it is certain that such cause is "not here on appeal," as stated at the bottom of page 38. Any bearing on any issue between the parties which allegations in the Knowles preliminary statements might have would apply to the issues in C. A. No. 5092, *not* here on appeal, rather than to the present case. That discussion should therefore be ignored by this court.

At page 39 of appellant's brief, Knowles' faulty recollection as to the disposition of the wooden model shown in Exhibit 4 is discussed, but again that has no bearing on the issues of the present case and there is no substantial dispute as to the facts here involved. The issue is to the application of law to those facts. All of the subject matter on pages 39, 40 and 41 is therefore apparently presented simply to create in the mind of

the court prejudice against Knowles on the basis of matters not here involved. All of that portion of appellant's brief should therefore be disregarded by the court.

CONCLUSION

In summary, it is respectfully submitted that this court should affirm the judgment of the district court that no completed or operational form of package freezer described in Knowles' patent No. 2,927,443 was available for use or on sale prior to or on May 23, 1951, or more than one year before the filing of Knowles' patent application.

Likewise, it is respectfully submitted that this court should affirm the judgment of the district court that the decision of the Patent Office Board of Patent Interferences, in Interference No. 88,174, awarding priority to Knowles, was a proper and correct decision, that Knowles patent No. 2,927,443 was properly awarded priority over Mackenzie patent No. 2,697,920, that the decision of the Patent Office Board of Patent Interferences, in Interference No. 88,174, constitutes a bar to the relitigation of all questions in the interference, and that the automatic and semi-automatic freezers manufactured by appellant and its related companies infringe Claims 13, 14, 15, 16 and 17 of Knowles patent 2,927,443.

Respectfully submitted,

ALFRED J. SCHWEPPE

ROBERT W. BEACH

ARTHUR S. LANGLIE

Attorneys for Appellees.

657 Colman Building,
Seattle 4, Washington.

CERTIFICATE OF COUNSEL

I certify that, in connection with the preparation of this brief, I have examined Rules 18 and 19 of the United States Court of Appeals for the Ninth Circuit, and that, in my opinion, the foregoing brief is in full compliance with those rules.

Arthur S. Langhe

Attorney for Appellees

**United States Court of Appeals
For the Ninth Circuit**

AMERIO CONTACT PLATE FREEZERS, INC., *Appellant*,

vs.

BELT ICE CORPORATION and FRANK W. KNOWLES,
Appellees.

APPEAL FROM THE UNITED STATES DISTRICT COURT FOR
THE WESTERN DISTRICT OF WASHINGTON,
NORTHERN DIVISION

REPLY BRIEF OF APPELLANT

ROBERT W. GRAHAM

J. KENNETH BRODY

FORD E. SMITH

Attorneys for Appellant.

14th Floor Norton Building,
Seattle, Washington.

FILED

NOV 10 1952

FRANK W. KNOWLES, CASE



No. 18177

United States Court of Appeals
For the Ninth Circuit

AMERIO CONTACT PLATE FREEZERS, INC., *Appellant*,

vs.

BELT ICE CORPORATION and FRANK W. KNOWLES,
Appellees.

APPEAL FROM THE UNITED STATES DISTRICT COURT FOR
THE WESTERN DISTRICT OF WASHINGTON,
NORTHERN DIVISION

REPLY BRIEF OF APPELLANT

ROBERT W. GRAHAM

J. KENNETH BRODY

FORD E. SMITH

Attorneys for Appellant.

14th Floor Norton Building,
Seattle, Washington.



INDEX

| | Page |
|--|-------------------|
| I. The "On-Sale" Issue..... | 1 |
| A. The Facts | 1 |
| B. The Facts Relied on by Appellees..... | 3 |
| C. Position of Appellant..... | 4 |
| D. The Position of Appellees..... | 7 |
| II. The Bar of 35 U.S.C. § 135..... | 12 |
| A. Appellant Is Not Estopped by <i>Res Judicata</i> to Assert this Statutory Bar..... | 13 |
| B. The Issue Presented..... | 14 |
| C. The Differences Between Knowles' Original and Amended Application Claims Are of Patentable Significance | 15 |
| Conclusion | 18 |
| Certificate of Counsel..... | 18 |
| Appendices A, B, C, D, E, F, G and H..... | following page 18 |

TABLE OF CASES

| | |
|--|-----------|
| <i>Andrews v. Hovey</i> (1887) 123 U.S. 267, 8 S.Ct. 101, 31 L.Ed. 160 | 7 |
| <i>Browning Manufacturing Co. v. Bros. Incorporated</i> (D.C. Minn., 1962) 134 U.S. P.Q. 231, — F.Supp..... | 10 |
| <i>Burke Electric Co. v. Independent Pneumatic Tool Co.</i> (C.A. 2, 1916) 232 Fed. 145..... | 8, 10, 11 |
| <i>Campbell v. Mayor, etc. of New York</i> (C.C. S.D. N.Y. 1888) 36 Fed. 260..... | 9 |
| <i>Chicopee Manufacturing Corp. v. Columbus Fiber Mills Co.</i> (M.D. Ga. 1958) 165 F.Supp. 307..... | 11 |
| <i>Connecticut Paper Products v. New York Paper Co.</i> (D.C. Md. 1941) 39 F.Supp. 127..... | 10 |
| <i>Egbert v. Lippmann</i> (1881) 104 U.S. 333, 26 L.Ed. 755..... | 7 |
| <i>Hutten v. Frank Krementz Co.</i> (C.A. 3, 1916) 231 Fed. 973..... | 9 |
| <i>McCreery Engineering Co. v. Massachusetts Fan Co.</i> (C.A. 1, 1912) 195 Fed. 498..... | 8, 10 |
| <i>Magee v. Coca Cola Co.</i> (C.A. 7, 1956) 232 F.(2d) 596..... | 11 |

| | |
|---|-------|
| <i>Metallizing Engineering Co. v. Kenyon Bearing & Auto Parts Co.</i> (C.A. 2, 1946) 153 F.(2d) 516..... | 4, 5 |
| <i>F. E. Myers & Bro. Co. v. Gould Pumps, Inc.</i> (W.D. N.Y., 1950) 91 F.Supp. 475..... | 10 |
| <i>Philco Corp. v. Admiral Corp.</i> (D.C. Del., 1961) 199 F. Supp. 797 | 4, 11 |
| <i>Rieser v. Williams</i> , C.C.P.A., 255 F.(2d) 419 (1958)..... | 14 |
| <i>B. F. Sturtevant Co. v. Massachusetts Hair & Felt Co.</i> (C.A. 1, 1941) 122 F.(2d) 900, reh. den. 124 F.(2d) 95.... | 9 |
| <i>Trico Products Corporation v. Delman Company</i> (S.D. Iowa, 1961) 199 F.Supp. 231..... | 9 |
| <i>Watson v. Allen</i> (C.A. D.C., 1958) 254 F.(2d) 342..... | 6, 7 |
| <i>Wende v. Horine</i> (C.A. 7, 1915) 225 Fed. 501..... | 11 |

STATUTES

| | |
|------------------------------------|--------------------|
| 35 U.S.C. § 135, 66 Stat. 801..... | 12, 13, 14, 15, 18 |
| 35 U.S.C. § 102..... | 14 |

RULES

| | |
|---|----|
| Patent Office Manual, § 1101.02(f)..... | 14 |
| Rule 292, Rules of Practice, United States Patent Office, 35 U.S.C. Apx. 1.292, p. 740..... | 11 |

United States Court of Appeals For the Ninth Circuit

AMERIO CONTACT PLATE FREEZERS, INC.,
Appellant,
vs.
BELT-ICE CORPORATION AND FRANK W.
KNOWLES,
Appellees.

No. 18177

APPEAL FROM THE UNITED STATES DISTRICT COURT FOR THE
WESTERN DISTRICT OF WASHINGTON
NORTHERN DIVISION

REPLY BRIEF OF APPELLANT

I. THE "ON-SALE" ISSUE

A. The Facts.

To the ten-page narrative of the facts upon which the issues before this court are founded (appellant's brief, pp. 3-12), appellees have added only one and one-half pages of "clarification" (appellees' brief, pp. 1-3), of which a substantial portion is devoted to a discussion of the definitions of "prototype" and "mockup."¹ Appellees state, at page 48 of their brief, that "there is no substantial dispute as to the facts herein involved. The issue is to the application of law to these facts." We read this as a general comment upon all of the facts of this case.

¹Appellant did not originate this terminology. See, for instance, the colloquy set forth at page 25 of appellant's brief in which his counsel is questioning Appellee Knowles:

"Q 74. What was the next activity regarding the package freezer following the construction of the *prototype*?"

"A. I actually sold one—I sold two, rather, to the Evergreen Frozen Foods from the *prototype* and the preliminary sketches." (Italics supplied)

Page 6 of appellant's brief shows successive references in the Knowles' diaries, Ex. 50 and 51, on December 11, 1950, December 13, 1950, and December 15, 1950, to the "mockup." These are, of course, only examples.

Granted that appellees have not taken substantial issue with the narrative history presented by appellant, there is, as pointed out in appellant's brief, p. 25, a critical dispute as to certain facts or factual conclusions involved. That dispute involves a crucial issue—whether Knowles was in fact building two freezers incorporating the invention to the special order of Evergreen prior to May 23, 1951, or whether they were built “on speculation.”

In this dispute, although there are two sides, there is only one disputant—Knowles. In his 1958 testimony in Interference No. 88,174, Knowles stated directly that, following the construction of the prototype, he sold two freezers to Evergreen from the prototype and the preliminary sketches. He said that he ordered Dole refrigerating plates in January, 1951, because he had taken an order for two package freezers from Evergreen, having verbally agreed that delivery would be made the first of June so that the plant would be ready for peas about the first of July.²

Nevertheless, at the trial, Knowles testified that the thirty Dole plates had been ordered “purely on speculation” (Tr. Vol. 3, 317), and that he built the two freezers on “speculation and didn't get an order for them until June some time” (Tr. Vol. 3, 318).

The ultimate truth is not consistent with the two positions that Knowles has taken. That is why his credibility is of significant importance. We cannot, therefore, agree with appellees that our discussion of credibility is “. . . apparently presented simply to create in the mind of the court prejudice against Knowles on the basis of matters not here involved.” (Appellees' brief, pp. 48-49).

²See pp. 9-11, appellant's brief.

B. The Facts Relied on by Appellees.

Appellees have not attempted to analyze and assess the importance of *all* of the facts in this case. Instead, they have attempted to isolate two factual issues and have rested their case upon these two asserted facts.

The first such asserted fact is that there was no completed and fully operational machine in existence on May 23, 1951. The second asserted fact is that no sale document had been executed on or before that date.

As to the first, it is undisputed that one machine was complete by May 23, 1951, save only for refrigerating plates. These were standard elements which Knowles knew would work and had only to insert. The invention itself was in working order, capable of achieving the necessary spacing.³ As to the second, the purchase order for the two machines was dated June 23, 1961—after the machines had been shipped to Evergreen on June 19 and 21.⁴

We have attempted to compile and to analyze all of the significant facts. We do not think it necessary to repeat that narration and analysis here. Beyond the explicit sworn testimony of Knowles that he sold two freezers to Evergreen from the prototype, having taken an order for two package freezers for delivery on the first of June for the 1951 pea crop, we believe that the entire record demonstrates a vendor-vendee relationship between appellees and Evergreen, commencing in December, 1950. As we have pointed out, Evergreen not only ordered the two freezers, but it constructed a special room to house them, built to the drawings of Knowles. Evergreen relied upon this freezing capacity, not only for the 1951 pea crop, but also for other 1951 crops. The record leaves no doubt that Evergreen knew what it was buying as early as December, 1950, and that Belt Ice

³ See p. 11, appellant's brief.

⁴ See p. 30, appellant's brief.

proceeded, as expeditiously as possible, to construct two machines for the use and to the order of Evergreen.

It is significant to note from the chronological narrative involved that there was no suggestion that the machine would have to be experimentally tested or would be subject to further development and experimentation before Evergreen would make its decision to buy. That Evergreen had made its purchase decision as early as December 20, 1950, is clear (Ex. 50, entry of December 20, 1950). This in turn reflects upon the size and character of the mockup. Far from being an insubstantial thing of "scrap lumber," it performed so well as to sell two freezers to Evergreen. Examination of the photograph, Ex. 4, will serve to clarify this point.

We believe that appellees' failure to consider all of the facts contained in the record has led to a legal analysis on their part which is too narrow and restrictive to give meaning to the statute. We believe that the facts of this case, as summarized in appellant's brief, and the statutory language alone would be sufficient to dispose of this case.

C. Position of Appellant.

We have discussed, at pages 19-22 of appellant's brief, our concept of the policy of the statute involved. The policy is clear and understandable. Appellees have stated, at page 22 of their brief, that:

"Appellant does not really explain its understanding of 'competitive use,' nor does it clearly apply that term to the facts of the present case. It mentions 'competitive sales effort,' but there is no proof of competing sales in this case."

In *Philco Corp. v. Admiral Corp.* (D.C. Del., 1961), 199 F. Supp. 797, the court relied upon Judge Hand's discussion and decision in *Metallizing Engineering Co. v. Kenyon Bearing & Auto Parts Co.* (C.A. 2, 1946), 153 F.(2d) 516, stating:

“Judge Learned Hand held that an inventor cannot be allowed to use his device competitively more than one year prior to his patent application no matter how little the public learns of the invention. It was reasoned that such a competitive use prior to a patent application is the effective equivalent of an extension of the patent monopoly.” (199 F. Supp. at 816).

What appellees do not understand, perhaps, is the policy which the court in *Philco* said had been “delineated so cogently” in *Metallizing*. But at the quoted juncture of their brief, appellees do not attempt to analyze the facts or the opinion in *Metallizing Engineering Co. v. Kenyon Bearing & Auto Parts Co.*, (C.A. 2, 1946), 153 F.(2d) 516. Their discussion of this case, at page 10 of their brief, is limited to an attempt to distinguish it on the basis that the device in *Metallizing* was in commercial use for more than one year prior to the filing of the patent application. Such a limited analysis does not lead to an understanding of the policy significance of the decision which, admittedly, dealt with the “public use” rather than the “on sale” portion of the statute.

We believe that the various attempts by appellees to sell their invention in late 1950 and early 1951, and more specifically the relationship with Evergreen which, commencing in December, 1950, in one continuing and connected transaction led to the sale of two machines, constituted a true competitive use of the invention — an invention which Knowles’ affidavits and sworn testimony make clear had been reduced to practice.⁵ To make an invention commercially available, to take orders for it, and to construct two machines for specific delivery and ultimate payment on the basis of these actions is a use of the invention competitive with any other invention or machine which Evergreen might have purchased for use in the 1951 freezing season.

Appellees state, at page 6 of their brief:

⁵See appellant’s brief, pp. 5-6.

“. . . that the invention of the Knowles patent could only be offered for sale as embodied in a full-sized working machine.”

We think the facts of this case show that the invention was in fact offered for sale on the basis of the mockup or prototype and was successfully sold in that manner. Likewise, we do not understand the statement of appellees, at page 23 of their brief, that:

“. . . An ‘invention’ has no existence apart from its embodiment in a machine . . .”

Apparently the invention had a substantial enough existence in December, 1950, and certainly in January, 1951, to persuade Evergreen that it should utilize this invention in its 1951 operations and could count on doing so.

Appellees have queried (appellees brief, p. 23) the observation of appellant that a restatement of the underlying policy of the statute is found in *Watson v. Allen* (C.A. D.C., 1958), 254 F(2d) 342. That case dealt with “public use,” but the following portions of the court’s opinion are significant:

“It may be fair to conclude that public use exists where the invention is used by or exposed to any one other than the inventor or persons under an obligation of secrecy to the inventor. Under such sweeping interpretations, we have no choice but to conclude that the appellee’s shims were in public use even though the buyer did not know of the presence of the shims in the car . . .

“The cases seem to be hospitable to the inventor during the *experimental stage* of his invention, but become disposed to construe the law against him thereafter. The judicial policy underlying this rule has been said to be that an inventor acquires an undue advantage over the public by delaying to take out a patent inasmuch as he thereby preserves the monopoly to himself for a longer period than the law allows. . . .
“. . . Our conclusion is that the courts accord considerable hospitality to the inventor during the experi-

mental stage. However, as a limitation we note that this hospitality disappears even during the experimental stage when the 'experimental motive' wanes, or is superseded by a profit motive, or is tainted by careless acts of the inventor." 254 F.(2d) at 345-346.

Surely the whole relationship between appellees and Evergreen was based upon the profit motive of exploiting appellee's invention. Nor was it a generalized profit motive such as the showing of an invention in the hope of obtaining customer interest. Seller and buyer knew at all times what they intended to do. The seller's demonstration of the invention, his undertaking to build two machines for the buyer, and his activity to that end, long before May 23, 1951, were all in quest of financial gain from this invention.

We have cited *Egbert v. Lippmann* (1881), 104 U.S. 333, 26 L. Ed. 755, for the proposition that a single instance of use will suffice to raise the statutory barrier, and it is immaterial that the invention is given without profit, or that it is invisible to the public eye. Indeed, *Andrews v. Hovey* (1887), 123 U.S. 267, 8 S. Ct. 101, 31 L. Ed. 160, carries this doctrine one step farther and holds that it is immaterial that the use is without the inventor's consent, or due to factors not his fault and beyond his control.

If a single, non-experimental use beyond the cutoff date invalidates the patent, the words "on sale" are surplusage unless they signify something different from "public use." "On sale" must mean something different from and at the same time less than the single instance of public use prescribed by the cases. It means a placing "on sale" even if the sale is never made. It means, as we understand the doctrine, a competitive effort, whether or not a sale takes place.

D. The Position of Appellees.

Appellees take the position that the on sale doctrine may be invoked only when there exist: (1) a "full-sized work-

ing machine”⁶ available for sale and delivery, and (2) a completed sale,⁷ as such would be defined under the law of sales.

The cases are numerous and conflicting. Appellees rely on language which is in many cases purely dictum. Few decisions attempt to offer a rationale for the statute. Since this case will establish a precedent governing this circuit, we believe its decision must be based upon a sound analysis of the purpose and intent of the statute, as well as the language of cases all of which cannot perhaps be reconciled.

Turning to the cases relied upon by appellees, the decision in *McCreery Engineering Co. v. Massachusetts Fan Co.* (C.A. 1, 1912), 195 Fed. 498, makes it clear that there had been no reduction to practice prior to the cutoff date. This is the time basis of the decision. The court concluded that the drawings and verbal descriptions on which the agreement was based, however completely they might show conception, would not establish reduction to practice unless filed as a patent application which accomplishes a constructive reduction to practice. Knowles’ sworn preliminary statements⁸ (Ex. 37 and 38) show reduction to practice by October, 1950.⁹ Without reduction to practice, there cannot be a competitive use. *McCreery* therefore accords with the appellant’s position.

In *Burke Electric Co. v. Independent Pneumatic Tool Co.* (C.A. 2, 1916), 232 Fed. 145, the motor was delivered on

⁶ Appellees’ brief, p. 6.

⁷ See pp. 20-21, appellees’ brief.

⁸ The use of the word “affidavit” in appellant’s brief was intended to do more than indicate that the preliminary statements were in fact sworn statements. Appellees complain of our drawing attention to the inconsistency in Knowles’ preliminary statements “without further explanation” (appellees’ brief, p. 46). An issue which inheres throughout the case, it may be noted, is that of Knowles’ credibility. See p. *supra*.

⁹ See appellant’s brief, pp. 5-6.

September 9, 1909. The motor delivered was a "first sample . . . subject to your approval."

This was properly held to be a sale by sample. The sample was not submitted till after the cutoff date. The inventor could have changed the motor at any time prior to delivery and the buyer need not have accepted it. The invention and the device were not in final form prior to the cutoff date. Further experiment or change was indicated as possible and acceptable. The case simply recognizes that unless an invention has been reduced to practice and final in its form, it cannot be said a competitive use has been made of it.

In *Campbell v. Mayor, etc. of New York* (C.C. S.D. N.Y., 1888), 36 Fed. 260, the issue was purely procedural and plaintiff was given leave to take and file testimony as to whether the engine sold actually incorporated the invention and as to fraudulent and surreptitious use of the invention prior to the cutoff date. The discussion of the on sale doctrine appears to be dictum. As with all cases in the Second Circuit, including *Burke*, we believe they must be considered as modified by the *Metallizing* decision insofar as they may be in conflict with it.

B. F. Sturtevant Co. v. Massachusetts Hair & Felt Co., (C.A. 1, 1941), 1922 P.(2d) 900, reh. den. 124 F.(2d) 95 is difficult to follow on the facts. Analysis of the case would appear to indicate that the whole discussion of the on sale defense raised as to the second of two patents involved is dictum.

In *Trico Products Corporation v. Delman Company*, (S.D. Iowa, 1961), 199 F. Supp. 231, the samples were submitted to the automobile manufacturers for testing and trade reaction. There was no effort or intent to sell the products. In essence, therefore, there was not a competitive use of the invention. The same may be said of *Hutten v. Frank Krementz Co.* (C.A. 3, 1916), 231 Fed. 973, where the eyeglasses were left with Meyrowitz to show only. There

was no subsequent sale of the articles. Instead they were returned. The court's decision may be read as a clear statement that there had been no competitive use of the invention.

In *Connecticut Paper Products v. New York Paper Co.*, (D.C. Md., 1941), 39 F. Supp. 127, negotiations outside the cutoff period were based upon "an imperfect model." It is not clear whether the "imperfect model" constituted a reduction to practice. In this case, as in *F. E. Myers & Bro. Co. v. Gould Pumps, Inc.*, (W.D. N.Y., 1950), 91 F. Supp. 475, the language of *Burke Electric Co. v. Independent Pneumatic Tool Co.*, supra, (C.A. 2, 1916), 234 Fed. 93, is relied upon and the authority of *McCreery Engineering Co. v. Massachusetts Fan Co.*, supra, (C.A. 1, 1912), 195 Fed. 498, is cited.

In the final analysis, we can learn much from *Browning Manufacturing Co. v. Bros., Incorporated* (D.C. Minn., 1962), 134 U.S.P.Q. 231, — F.Supp. —. The machine there was exhibited at a trade show; a pamphlet was distributed stating the price thereof. It should be noted that the case turned upon an issue of publication rather than an on sale issue. However, in considering the latter issue, the court said:

"A sound analysis of the entire testimony, however, would indicate that Bros's activities upon which the plaintiffs rely were directed at sounding out the industry's reaction to the machine and indicated the price at which it would be sold after the company had fully tested the machine, and if the test proved satisfactory then the company would be ready thereafter to place the machine on the market for sale at the proposed price."

The key words are: "*a sound analysis of the entire testimony . . .*" Herein, we believe lies the failure of appellees' analysis of this case.

There was in *Browning* only a general showing to the

trade. There was no specific buyer in view, as there was in the case at bar; hence there was no direct competitive use of the invention. The conclusion is reinforced by the court's finding that the machine was to be fully tested before it could be placed on the market. As in *Burke*, the invention had not reached that ultimate stage where it was to be the subject of competitive use. In our own case, as we have noted, there is no suggestion that Evergreen would defer its decision to buy until after certain tests or experiments had been completed. From early 1951, Evergreen knew it would use the Knowles freezers for its 1951 crops and did.

Appellees have sought to distinguish *Chicopee Manufacturing Corp. v. Columbus Fiber Mills Co.* (M.D. Ga. 1958) 165 F. Supp. 307, on the basis of a sale by sample. Such a position seems to negate the principal theory put forward by appellees that there must be in existence a completed functional and operating specimen of the invention which is available for sale and delivery. The *Chicopee* case, like *Wende v. Horine* (C.A. 7, 1915), 225 Fed. 501; *Magee v. Coca-Cola Co.* (C.A. 7, 1956), 232 F.(2d) 596, and, of course, explicitly, *Philco Corp. v. Admiral Corp.* (D.C. Del., 1961), 199 F. Supp. 797, demonstrate the theory of competitive use as the criterion for application of the on sale doctrine.

It should be noted, parenthetically, that the on sale issue was neither heard nor determined in the Patent Office proceedings, nor could it have been.¹⁰

Perhaps the authorities show that courts have not always seen that the criterion is the placing of the invention *on sale* rather than any manufacture incorporating the invention. The criterion is not a technical sale as defined by the law of contract or the law of sales. The underlying purpose of the statute is to bar an unwarranted extension of

¹⁰ See Rule 292, Rules of Practice, United States Patent Office, 35 U.S.C. Apx. § 1.292, p. 740.

the patent monopoly by a competitive use of an invention out of a profit motive more than one year prior to the date of the patent application.

Under the circumstances, each case must be decided upon its own facts. We believe that we have clearly shown that the invention had been reduced to practice as Knowles himself repeatedly asserted and was final in its form as embodied in the mockup, that appellees intentionally offered their invention for sale in November and December, 1950 and January, 1951 by use of the mockup to numerous persons and especially to Evergreen. We believe the evidence fairly shows a competitive use of the invention when, in January, 1951, Evergreen ordered the two machines which appellees then commenced to build in the image of the mock-up and in fact furnished for scheduled use in June of 1951.

II. THE BAR OF 35 U.S.C. §135

In appellant's opening brief at page 42-45 and in Questions Presented 2, 3 and 4 (pp. 12-13) and Specifications of Errors 3, 4, 5 and 6 (pp. 13-14), appellant asserts that Knowles was precluded from adding application Claims 25, 26, 27, 28 and 29 on March 23, 1956 to his pending application for the reason that these claims were "for the same, or substantially the same, subject matter" as the McKenzie Patent Claims 3, 6, 7, 10 and 12 and not having been asserted within one year from the date of issue of the McKenzie patent on December 28, 1954, were barred by the provisions of 35 U.S.C. §135, 66 Stat. 801.

Nor did Knowles' amended claims embrace the same or substantially the same subject matter which he had claimed within the critical year following the issue of the McKenzie Patent. In other words, during the critical year, Knowles was claiming something different from the subject matter of his amended claims which were added after the critical year.

A. Appellant Is Not Estopped By Res Judicata to Assert This Statutory Bar

Appellees assert that appellant cannot raise this issue on this appeal for the reason that there has been no appeal from the judgment in C.A. 5092 with which this action was consolidated for trial in the court below. (Brief of appellees, pp. 26-30).

The record is clear that the questions here presented were in issue and were determined adversely to appellant in the court below in this action, C.A. 5171. In "Plaintiff's Contentions as to C.A. 5171" in the Pre-Trial Order it is asserted that the invention contained in Knowles' application claims 25-29, filed more than one year after the date of issue of the McKenzie patent, was substantially different from the invention claimed during the critical year after December 28, 1954 (No. 4, Pre-Trial Order, p.20). Furthermore, it is contended in "Defendant's Contentions as to C.A. 5171":

"The invention of Knowles' patent application Claims 25, 26, 27, 28 and 29, corresponding to Claims 13, 14, 15, 16 and 17 of Knowles' patent No. 2,927,443, respectively, is not different from the invention which has been claimed in Knowles' patent application Ser. No. 289,638 prior to December 28, 1955." (No. 5, Pre-Trial Order, p.22)

and, most important, the Trial Court, in its judgment in C.A. 5171, ruled on this issue by making Conclusion of Law 2, in the identical language of appellees' contention quoted above. It is from this judgment that this appeal is taken.

In C.A. 5092, the issues of priority of invention and fraud in the procurement of the Knowles patent were determined adversely to appellant. From those determinations no appeal has been taken. On this appeal from the judgment in C.A. 5171, appellant asserts the statutory bar to the validity of the Knowles' patent raised by 35 U.S.C. §135 as well as

the bar of 35 U.S.C. §102, both of which issues were tendered to and determined by the court below in this action.

B. The Issue Presented

To avoid the bar imposed by 35 U.S.C. § 135, appellees preface that portion of their brief discussing the pertinent rule with the caption statement "35 U.S.C.A. §135 only requires that *the same general subject matter* have been claimed within a year after patent issues." (p. 34, emphasis added). Section 1101.02(f) of the Patent Office Manual, on which appellees rely and which is supported by the rule of *Rieser v. Williams*, C.C.P.A., 255 F(2d) 419 (1958) formulates the test differently:

"It should be noted that an applicant is permitted to copy a patent claim outside the year period if he has been claiming *substantially the same subject matter* within the year limit."

There is a vast difference between claiming "the same *general* subject matter" and claiming "*substantially the same* subject matter" in prior claims. As properly formulated under the rule of *Rieser v. Williams*, with which we find no necessity for disagreement, the test to be applied in determining whether or not Knowles is barred by 35 U.S.C. §135 from asserting his added application Claims 25-29 more than one year after the date of issue of the MacKenzie patent, presents the inquiry as to whether or not his amended claims filed March 23, 1956 embraced "substantially the same subject matter" as that previously pending in his original application claims.

Phrased in reverse, the issue is presented as to whether or not the differences between the original Knowles application claims and the tardily presented amended claims which became the counts in interference were of "patentable significance" within the rule of *Rieser v. Williams*.

It is appellant's contention that the differences between the original Knowles' application claims and the amended

claims were of "patentable significance" and contrary to appellees' assertion (appellees' brief, p.41), does contend that these added claims did not embrace "substantially the same subject matter" as Knowles' original application claims.

Significantly, appellees' brief offers the court no help or assistance in resolving these issues and, having learnedly developed a generalized statement of law which appellant finds unnecessary to dispute, simply rests upon the fact that the Patent Office Board of Patent Interferences ruled adversely to appellant upon the issue of the bar of 35 U.S.C. §135.

C. The Differences Between Knowles' Original and Amended Application Claims Are of Patentable Significance.

Appellees complain of the failure of the Patent Office to declare an interference during the copendency of the MacKenzie and Knowles applications.¹¹ The simple answer to this is that Knowles did not, until more than a year after the issuance of the MacKenzie patent, file claims commensurate in scope to those patented to MacKenzie. Examiner Keaveney had both applications on his desk simultaneously and was bound to compare what the two parties were claiming.¹² His inaction indicates the opinion that there was no interference. Examiner Yudkoff cited the MacKenzie patent to Knowles as merely being "of interest." Since Knowles was not claiming the same subject matter as MacKenzie, he, too, saw no interference. Thus Examiners Keaveney and Yudkoff concurred on this important question.

Confronted with the MacKenzie patent, Knowles nevertheless devised a means to get into interference in order to test the issue of priority of invention. He drafted his claims 25-29 and submitted them by amendment (Ex. 28, p. 53 et

¹¹ See p. 33, appllees' brief.

¹²35 U.S.C. § 135, see quotation, p. 34, appellees' brief.

seq.) on March 23, 1956, more than one year after the MacKenzie patent had issued. The Examiner, on April 10, 1956, required Knowles (Ex. 28, p. 77) to *copy* MacKenzie Claims 3, 6, 7, and 10. Under date of May 11, 1956, Knowles replied (Ex. 28, pp. 78 et seq.) that he could not copy the mentioned MacKenzie claims and stated there was "a serious question" (Ex. 28, p. 79, line 14) that he could make MacKenzie's claims. Knowles then revised or patterned his claims more closely after the MacKenzie claims. His original disclosure would not support his copying the MacKenzie patent claims. Amendments were then ordered (Ex. 28, p. 78), the Examiner was personally interviewed (Ex. 28, p. 71) and thereafter the patent interference was declared (Ex. 28, p. 83). It was at this very point that the basic error was made. The patent office overlooked the bar raised by 35 U.S.C. § 135 by failing to recognize that Knowles had not originally or previously as broadly claimed the subject matter of the counts.

To illustrate graphically the differences between Knowles' original application claims and the amended claims or counts in interference (as well as the MacKenzie claims from which they were synthesized), Appendices A, B, C, D, E, F, G and H are attached. Appellees have, as we have noted, failed to make any attempt to meet the vital issue, and have simply assumed, at all times, that there was no substantial difference between the Knowles application and the subsequent amendments—an issue which the actions of Examiners Keaveney and Yudkoff as well as appellant dispute.

Appendices A, B, C and D compare the Knowles application, Claim 5, pending at the time the MacKenzie patent issued, with interference Counts 1, 2, 3 and 4 which were introduced into Knowles' application only on March 23 and May 11, 1956, and with MacKenzie's patent Claims 3, 6, 7 and 10. Similarly, Appendices E, F, G and H compare Knowles' application Claim 6 in each instance with Mac-

Kenzie's patent Claims 3, 6, 7 and 10 and interference Counts 1, 2, 3 and 4 respectively.

Appendices A, B, C and D show that in his Claim 5, Knowles originally claimed a plate freezer comprising "a frame" and "a cage in said frame". MacKenzie's "casing" enclosed a vertical stack of relatively operable refrigerated plates, but no "cage". MacKenzie's "casing" was a broader claim than Knowles' "frame" and "cage" in his plate freezer which was designed to be installed in an insulated room such as was specially constructed by Evergreen. By amendment, Knowles converted MacKenzie's "casing" into "an enclosing structure" and then argued that his "frame" and "cage" was in essence the same. Appellant submits that Knowles' Claim 5 was narrower in a substantial and patentably critical instance from the tardily added claims which ripened into the allowed claims of the Knowles patent and that the counts in interference cannot be equated with the subject matter of Knowles' Claim 5 which was pending during the critical year.

Similarly, as reflected in Appendices E, F, G and H it will be noted that Knowles had introduced his claim as "a plate freezer" without reference to any structure and without reference particularly to "a casing" as called for by MacKenzie or "an enclosing structure" as called for by the four counts in interference. The specific limitation in Knowles' Claim 6 is found in the language "dogs fixed at said station". By comparison with the MacKenzie claims and the several counts in interference it will be seen that in the latter two instances the Claims are broader in the recitation of "stop means" and, in particular, in the fact that they recite no structural limitation that they be "fixed at said station".

It is believed that these comparisons establish, as the patent examiners concluded, that Knowles, during the critical year, was not claiming substantially the same subject

matter as his late-added Claims 25, 26, 27 and 28, which became, respectively, Counts 1 through 4 in interference, and that the Patent Office Board of Patent Interferences erroneously concluded that the addition of Knowles' amended claims which precipitated the interference was not barred by 35 U.S.C. § 135.

CONCLUSION

In two significant respects appellee Knowles has run afoul of the expressed policy of Congress that dilatory action of a patent applicant shall not be permitted to extend the patent monopoly. Knowles failed to file his original patent application within one year after he had placed his invention on sale as required by 35 U.S.C. § 102 and he failed to claim the subject matter of the MacKenzie claims within one year following the issue of the MacKenzie patent as required by 35 U.S.C. § 135. For these reasons as indicated above and in appellant's opening brief, it is believed that the judgment of the Court below must be reversed.

Respectfully submitted,

ROBERT W. GRAHAM

J. KENNETH BRODY

FORD E. SMITH

Attorneys for Appellant.

CERTIFICATE OF COUNSEL

I certify that, in connection with the preparation of this brief, I have examined Rules 18 and 19 of the United States Court of Appeals for the Ninth Circuit, and that, in my opinion, the foregoing brief is in full compliance with those rules.

.....
, Attorney.

21 December, 1962

No. 18180 ✓

*See also
Vol. 3191*

IN THE
UNITED STATES COURT OF APPEALS
FOR THE NINTH CIRCUIT

FORMULABS, INCORPORATED, a corporation,
CLARENCE SCHREUR and GORDON S. LACY,
individuals doing business as PACIFIC
RESEARCH LABORATORY, a co-partnership,

Appellants,

vs.

HARTLEY PEN COMPANY, a corporation,
doing business as THE HARTLEY CO., and
E. I. du PONT de NEMOURS & COMPANY, a
corporation,

Appellees.

APPELLEE HARTLEY PEN CO.'S
ANSWERING BRIEF

FILED

JAN - 8 1939

FRANK B. SCHMID, CLERK

OWEN A. BARTLETT and
A. V. FALCONE
416 West 8th Street
Los Angeles 14, California

Attorneys for Appellee
Hartley Pen Co.



TOPICAL INDEX

| | <u>Page</u> |
|---|-------------|
| Appellee Hartley Pen Co.'s Answering Brief | 1 |
| Preface | 1 |
| I The Intervenor's' Brief in Cause No. 17741 | 23 |
| Preface | 23 |
| A. The Argument on Said Appeal | 23 |
| 1. That the owner of a trade secret has exclusive right to it. | 23 |
| 2. That the property owner has the constitutional right to assert his property rights in a court having juris- diction of the property. | 25 |
| 3. That intervenors were given the right to intervene by this Court in 275 F.2d 52. | 25 |
| 4. That the order of January 10, 1962 ordered disclosure of the trade secrets which the inter- venors seek to enjoin. | 30 |
| 5. That said order was a denial of the motion. | 30 |
| 6. That the said order was appealable. | 30 |
| 7. That if the intervenors' appeal is defective it should be considered as a petition for extraordinary writs. | 30 |
| B. The Argument as a Petition for Writs. .. | 31 |
| 1. As to the intervenors' alleged purpose of intervention. | 31 |

1870

...

...

...

...

...

...

...

...

| | <u>Page</u> |
|--|-------------|
| 2. Intervenors contend that their right to protect their property was adversely decided without being given their day in court and this constitutes an abuse of discretion and a violation of due process. | 34 |
| C. The Argument on du Pont's Motion to Dismiss the Appeal in 17741. | 36 |
| II The Intervenors' Brief in Cause No. 18180 | 36 |
| Preface | 36 |
| The "Statement of the Case". | 37 |
| The Specifications of Error. | 39 |
| The Summary of Argument. | 44 |
| Argument. | 44 |
| Preface | 44 |
| 1. That the court erroneously held that it had no jurisdiction. | 45 |
| 2. That the court erred in holding that the intervenors could intervene only by joining Hartley against du Pont. | 49 |
| 3-4. That the court erred in not following the "law of the case" and in refusing to accept, as res judicata, this Court's decision in 275 F.2d 52. | 53 |
| 5-6. That the district court erred in denying the motion for preliminary injunction and in holding that "publi- | |



| | <u>Page</u> |
|---|-------------|
| cation" of the trade secret would not "irreparably injure intervenors". | 61 |
| 7. That the court erred in holding that du Pont's pro- cedural discovery right "transcends" intervenors' ownership rights in their property. | 65 |
| Conclusions. | 69 |
| III Hartley's Argument. | 71 |
| Conclusion | 76 |

THE UNIVERSITY OF CHICAGO
DEPARTMENT OF CHEMISTRY
5800 S. UNIVERSITY AVENUE
CHICAGO, ILLINOIS 60637

PROFESSOR [Name]
[Address]
[City, State, Zip]

1980

100

TABLE OF AUTHORITIES CITED

| <u>Case</u> | <u>Page</u> |
|---|---|
| Electrical Research Products v. Gross, (CCA 9, 1941), 120 F.2d 301 | 58 |
| Fidelity & Deposit Co. of Maryland v. Port of Seattle, (CCA 9, 1939), 106 F.2d 777, cert. den. (1940) 309 US 661 | 58 |
| Formulabs v. Hartley Pen Co., 275 F.2d 52 | 3, 14, 15, 16 19, 22, 24, 25, 36, 39 42, 45, 48, 51, 53, 54 55, 56, 70, 75, 76 |
| Hartley Pen Co. v. U.S. District Court, 287 F.2d 324 | 3 |
| Higgins v. California Prune & Apricot Growers, (CCA 2d, 1924), 3 F.2d 896, 9 | 59 |
| Hurn v. Ousler, 289 US 238, 42 | 72 |
| Kemp v. United States, (CCA 8, 1947), 160 F.2d 406 (pt. 1), cert. den. (1947), 331 US 843 | 59 |
| Krippendorf v. Hyde, 110 US 276 | 28, 67 |
| Morgan's Company v. Texas Central Railway, 137 US 171 | 29 |
| Partmar Corp. et al., v. Paramount Pictures Theatres Corp., et al., (1953), 347 US 89 | 61 |
| Salvoni v. Pilson, (CA DC, 1950), 181 F.2d 615, cert. den. 339 US 981 | 58 |

1911

1911

1911

1911

1911

1911

1911

1911

1911

STATUTES

Federal Rules of Civil Procedure

| | |
|---------------|--------------------------------|
| Rule 7(a) | 20 |
| Rule 13(g) | 19, 20 |
| Rule 24(a)(2) | 52 |
| Rule 24(a)(3) | 15, 23, 30, 48, 50, 52, 68, 70 |
| Rule 24(c) | 16, 43 |

TEXTS

| | |
|--|----|
| 1A Moore's Federal Practice, 4203-4204, ns. 13-14 | 58 |
| 1A Moore's Federal Practice, 4205, n. 20 | 59 |
| Restatement, Judgments, Sec. 68, Comment d | 60 |



IN THE
UNITED STATES COURT OF APPEALS
FOR THE NINTH CIRCUIT

FORMULABS, INCORPORATED, a corporation,
CLARENCE SCHREUR and GORDON S. LACY,
individuals doing business as PACIFIC
RESEARCH LABORATORY, a co-partnership,

Appellants,

vs.

HARTLEY PEN COMPANY, a corporation,
doing business as THE HARTLEY CO., and
E. I. du PONT de NEMOURS & COMPANY, a
corporation,

Appellees.

APPELLEE HARTLEY PEN CO.'S
ANSWERING BRIEF

Preface

This is Hartley's answer to the intervenors' opening brief on their appeal from the District Court's two orders, both dated July 26, 1962 and entered July 30, 1962, the first granting Hartley's motion to dismiss the intervenors' "Complaint in Intervention" and the second denying their motion for preliminary injunction.

The only authority for said opening brief was this Court's opinion in proceedings numbered 17741 and 17799,

1912

1912

Proceedings of the Board of Directors

1912

1912

1912

1912

1912

1912

1912

1912

1912

1912

IN THE
UNITED STATES COURT OF APPEALS
FOR THE NINTH CIRCUIT

FORMULABS, INCORPORATED, a corporation,
CLARENCE SCHREUR and GORDON S. LACY,
individuals doing business as PACIFIC
RESEARCH LABORATORY, a co-partnership,

Appellants,

vs.

HARTLEY PEN COMPANY, a corporation,
doing business as THE HARTLEY CO., and
E. I. du PONT de NEMOURS & COMPANY, a
corporation,

Appellees.

APPELLEE HARTLEY PEN CO.'S
ANSWERING BRIEF

Preface

This is Hartley's answer to the intervenors' opening brief on their appeal from the District Court's two orders, both dated July 26, 1962 and entered July 30, 1962, the first granting Hartley's motion to dismiss the intervenors' "Complaint in Intervention" and the second denying their motion for preliminary injunction.

The only authority for said opening brief was this Court's opinion in proceedings numbered 17741 and 17799,

THE HISTORY OF THE

REIGN OF

CHARLES THE FIRST

BY

JOHN

WILKINS

ESQ.

IN TWO VOLUMES.

LONDON,

Printed by R. CLAY AND COMPANY, PRINTERS, BUNGAY, SUFFOLK.

1794.

Price 10s. 6d.

dated July 11, 1962, in which this Court stated,

"In the event that the party or parties adversely affected by such ruling or rulings shall appeal from such ruling or rulings, such appeal or appeals shall be consolidated with the present appeal in Cause No. 17741 and with the petition in Cause No. 17799, and said Cause No. 17741 and the new appeal or appeals shall be submitted to this Court, without further oral argument on the briefs on file, the present record on appeal supplemented by the record of proceedings had in the District Court upon remand, and supplemental opening, answering and reply briefs on the legal question or questions presented by such new appeal or appeals."

The intervenors have partially succeeded in beclouding the clear issues between Hartley and du Pont (and the clear, separate and unrelated issues between Hartley and the Intervenors). Their said brief contains numerous disjointed references to the various previous proceedings before this Court in such a confused fashion that a proper perspective of the issues before this Court is lost.

To rectify this and focus the crux of this appeal

Hartley will synopsise the relevant background of the intervenors' efforts to intervene in this action, which began on February 5, 1958 and which promise to continue indefinitely, thereby patently delaying and damaging Hartley (which is its licensee and heavy royalty payer) in its main action against du Pont (who has been, is and will be aided and comforted thereby). The intervenors are thereby deliberately injuring Hartley to whom they owe their present position and serious contractual obligations and are knowingly thereby benefiting du Pont.

There have been the following proceedings before this Court:

1. Formulabs' appeal in Cause No. 16140 resulting in this Court's decision in 275 F.2d 52, the substance of which was that Formulabs was entitled to intervene in the discovery proceedings in the main action in which du Pont sought disclosure of Hartley's trade secrets.

2. Hartley's petition for extraordinary writs in Cause No. 17096 which resulted in this Court's decision in 287 F.2d 324, which vacated Judge Harrison's said disclosure orders.

3. The intervenors' appeal in Cause No. 17598, which involved an unusual, complex situation.

Beginning on June 30, 1961 the intervenors filed the following pleadings in intervention:

a. Schreur's and Lacy's motion to intervene as

cross-complainants together with a cross-complaint by all three intervenors for declaratory relief and injunction against Hartley only. This was opposed by both Hartley and du Pont.

b. "Pleading of Intervenor" by Formulabs alone, filed on July 14, 1961 (containing three alleged causes of action each against Hartley alone.)

c. "First Amended Pleading of Intervenor", filed on July 17, 1961, three days after the said "Pleading of Intervenor" and was precisely the same pleading with only some insubstantial amendments.

d. Hartley's notice of motion to strike from the said "First Amended Pleading of Intervenor" and also said "Pleading of Intervenor", if still effective, and also its motion to dismiss said pleadings.

e. On July 31, 1961 Judge Mathes granted Hartley's said motion to dismiss with leave to the first cause of action and without leave to the second and third causes of action, on the ground of want of jurisdiction of the subject matter, the same not being ancillary to the main action, there being no independent grounds of jurisdiction and no diversity. As to the first cause of action leave was granted to all three intervenors to intervene and oppose du Pont's efforts to obtain disclosure of the trade secret. The court stated, among other things, that it would never issue an injunction against

Hartley disclosing. The leave was explicitly stated to be "the leave . . . is to file a complaint in intervention, joining the Hartley Pen Company, the plaintiff, in opposing the efforts of the defendant to compel the disclosure of the secret formula". The court directed that a written order be prepared by Hartley. This was done but was not signed until the hearing of September 11, 1961 but dated as of July 31, 1961 and filed September 21, 1961.

f. "Complaint in Intervention" and motion for preliminary injunction by all three intervenors, filed on August 9, 1961.

g. Hartley's motion to dismiss said complaint and opposition to said motion for preliminary injunction, filed August 16, 1961. Du Pont's motion to dismiss the said complaint filed August 31, 1961.

h. Hearing of September 11, 1961. The court first granted Hartley's said motion to dismiss the said complaint but then vacated the order and continued all matters.

i. On September 15, 1961 the intervenors filed their notice of appeal from the said order signed on September 11, 1961, dated July 31, 1961 but not filed until September 21, 1961. Said notice of appeal was filed six days prior to the filing of the said written order. The same day the intervenors filed a designation of contents of

record on appeal and statement of points.

j. On September 25, 1961 Hartley filed its motion to correct and modify the record on said attempted appeal.

k. On November 13, 1961 the court, among other things, denied Hartley's said motion regarding the record on said appeal (appeal No. 17598). There was no printed record on said appeal.

l. On December 4, 1961 this Court made its order granting du Pont's motion to dismiss the said appeal, denied Hartley's similar motion as moot and treating the said appeal as a petition for a writ of mandamus denied the same.

4. The intervenors' appeal in Cause No. 17741. This also presented an unusual, complex situation as follows:

a. On January 10, 1962 Judge Mathes made a written order directing Hartley to answer du Pont's additional interrogatories and requests for admissions, which would call for the disclosure of the trade secrets. This order was filed on January 11, 1962.

b. Hearing of January 29, 1962. The intervenors sought to have Judge Mathes hear their said motion for preliminary injunction but he refused to do so. He also denied Hartley's motion to stay proceedings on the additional interrogatories and requests for admissions.

c. On February 1, 1962 the intervenors filed their notice of appeal, dated January 31, 1962, by which

1. Name of the person or organization

2. Address of the person or organization

3. Telephone number

4. Date of the first contact

5. Date of the last contact

6. Name of the person contacted

7. Position of the person contacted

8. Nature of the contact

9. Name of the person contacted

10. Position of the person contacted

11. Date

12. Name

13. Position

14. Date

15. Name

16. Position

17. Date

18. Name

19. Position

20. Date

21. Name

22. Position

23. Date

24. Name

25. Position

they purported to appeal from the said order of January 10, 1962 filed on January 11, 1962 which, as noted, ordered Hartley to answer the said interrogatories and requests for admissions. The intervenors appealed therefrom as "implicitly and effectively denying their said motion for injunction." This notice of appeal was in hybrid form. It was captioned as an appeal and stated that the intervenors appealed from said order but then it proceeded as a petition for extraordinary writs concluding with a prayer for such writs.

d. Du Pont's motion, dated February 23, 1962, to dismiss said appeal (numbered 17742 although it referred to said appeal No. 17741).

e. Hartley's memorandum, dated February 27, 1962, regarding du Pont's said motion to dismiss said appeal. Hartley stated its position that, among other things, the said order from which the intervenors attempted to appeal was not technically an appealable order but that in view of the extraordinary and urgent circumstances involved, it be construed and considered as a petition for alternative writs directed to requiring Judge Mathes to hear and determine the pending matters, i.e., Hartley's and du Pont's said motions to dismiss the only pending pleading by intervenors, their said "Complaint in Intervention" and their motion for preliminary injunction. Hartley pointed out that du Pont's said motion to dis-

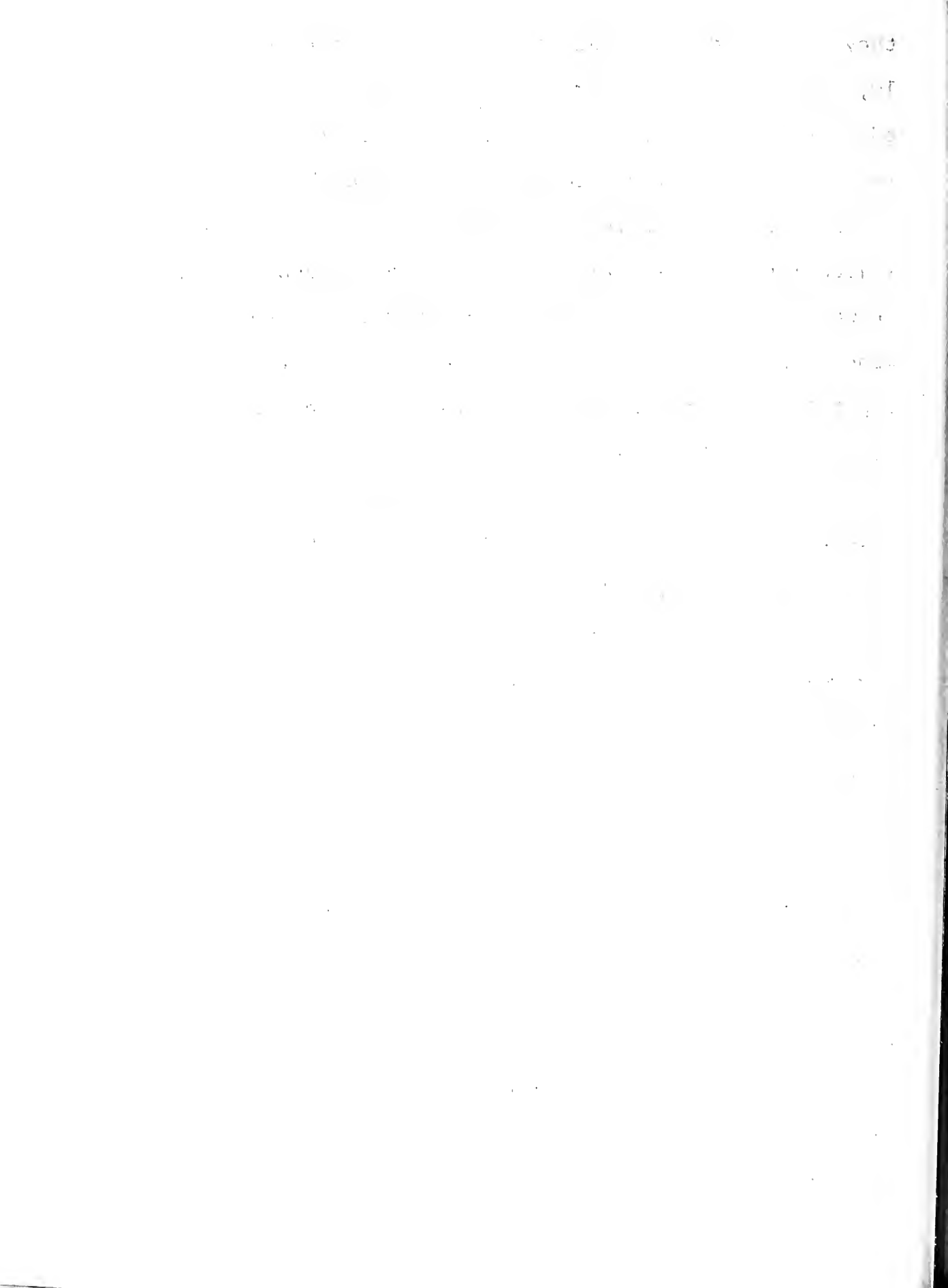

miss the said appeal did not consider said appeal as a petition for writs. Hartley informed this Court that it had advised Judge Mathes that on January 12, 1962 it had filed in the Los Angeles Superior Court an action for declaratory relief against the intervenors relating to their controversy as to their rights and obligations regarding the trade secrets and their relationship relative thereto. The intervenors' appeal or petition for writs, as the case may be, in Cause No. 17741 and du Pont's said motion to dismiss the same and Hartley's said memorandum regarding said motion, the latter two numbered 17742 but relating to 17741, are pending determination by this Court and have not yet been determined.

5. Hartley's petition for extraordinary writs in Cause No. 17799, the object of which is to seek a writ of mandamus vacating the said order of January 10, 1962 requiring Hartley to answer certain additional interrogatories and requests for admissions which would disclose the trade secrets. This is pending in this Court and undetermined.

6. On July 11, 1962 this Court rendered its opinion, captioned and numbered in both causes 17741 and 17799. Its substance was: (a) it vacated the submission of Cause 17741 and remanded it to the District Court "with the suggestion and request that the District Court expeditiously rule upon Formulabs' motion for pre-

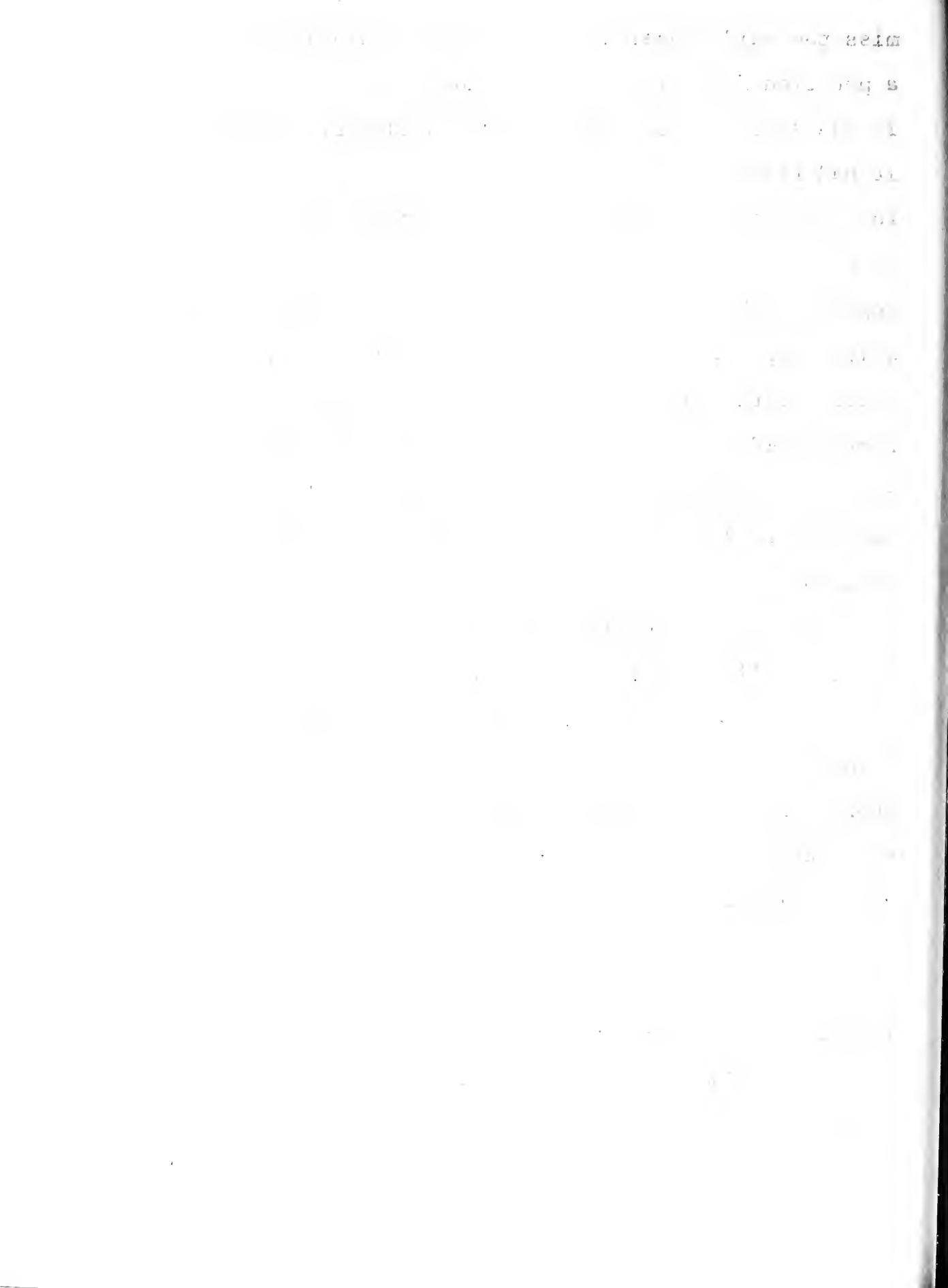

liminary injunction and du Pont's and Hartley's motions to dismiss the complaint in intervention" and (b) "vacated the submission of Cause No. 17799 to be deemed resubmitted without further oral argument on the present records and briefs upon resubmission of Cause No. 17741."

7. The intervenors' appeal in Cause No. 18180. This was based upon the following proceedings:

a. The District Court's written order dated July 30, 1962 and filed and entered the same day granting Hartley's and du Pont's said motions to dismiss the said "Complaint in Intervention" with leave to the intervenors to file an amended complaint in intervention within 20 days after service of the copy of the order, the amended complaint to be in conformity with the District Court's order of July 31, 1961 and specifically providing that the amended complaint "may not assert any claim against plaintiff arising out of any contract between plaintiff and intervenors, but may join plaintiff in opposing all efforts to compel disclosure of any secret formula or secret process or other trade secret in which intervenors may have or claim a property right or other legally cognizable interest, so that intervenors may, if so advised, participate in all future hearings and proceedings which may be had in this action concerned with any disclosure of any such secret formula

or secret process or other trade secret".

b. The Order for Final Judgment, entered on July 31, 1962. This was amended on August 6, 1962 by inserting or adding to it said provision for leave to intervenors to file within 20 days the explicitly defined amended complaint.

c. Pursuant to stipulation of the parties this Final Order was further amended on August 9, 1962 that the intervenors had 20 days after the return to the District Court of the mandate from this Court on this appeal within which to file the said amended complaint in conformity with the District Court's said order of July 31, 1961.

d. The intervenors appealed, by written notice dated August 10, 1962, from the order dismissing said "Complaint in Intervention," the said order denying their motion for preliminary injunction and the said Order for Final Judgment, as so amended. This appeal is pending in this Court. This brief by Hartley answers the intervenors' opening brief in this appeal.

References to the record will be made as follows:
To Cause No. 16140 by numbers preceded by 1 App.;
Cause No. 17096 by numbers preceded by 1 Pet.; Cause
No. 17598 by numbers preceded by 2 App.; Causes Nos.
17741 and 17742 by numbers preceded by 3 App.; Cause
No. 17799 by 2 Pet. and Cause No. 18180 by 4 App.

The first part of the document discusses the importance of maintaining accurate records of all transactions. It is essential for the company to have a clear and concise system in place to ensure that all financial data is properly documented and accessible. This will help in the preparation of financial statements and provide a clear picture of the company's financial health.

The second part of the document outlines the various methods used to collect and analyze data. It is important to use a variety of sources to ensure that the data is comprehensive and representative. This includes internal records, external data, and surveys. The analysis should be thorough and objective, taking into account all relevant factors.

The third part of the document discusses the results of the data collection and analysis. It shows that there is a significant correlation between the variables studied. This suggests that the factors being studied are indeed related and that the data collected is reliable. The results are presented in a clear and concise manner, making it easy to understand the findings.

The fourth part of the document discusses the implications of the findings. It suggests that the results have important implications for the company's operations and financial performance. It is important to take these findings into account when making decisions and to continue to monitor the data over time to ensure that the results remain valid.

The fifth part of the document discusses the limitations of the study. It is important to recognize that there are always limitations to any study, and this is no exception. The results of this study should be used as a guide rather than a definitive answer, and further research may be needed to confirm the findings.

The sixth part of the document discusses the conclusions of the study. It is clear that the data collected is reliable and that the results are significant. The findings suggest that the factors being studied are indeed related and that the data collected is comprehensive and representative. It is important to take these findings into account when making decisions and to continue to monitor the data over time to ensure that the results remain valid.

The seventh part of the document discusses the recommendations for future research. It is important to continue to study these factors and to explore new methods of data collection and analysis. This will help to improve the accuracy and reliability of the data and provide a clearer picture of the company's financial health.

The eighth part of the document discusses the final thoughts of the author. It is clear that this study has provided valuable insights into the company's financial performance and that the results are significant. It is important to take these findings into account when making decisions and to continue to monitor the data over time to ensure that the results remain valid.

The record in 16140 consists of the printed transcript of record on appeal. The record in 17096 consists of the petition and its appendix. The record in 17598 consists of intervenors' "Designation of Portions of Record Appellants Request Be Printed"; Hartley's objections thereto and designation of record. There is no printed record therein. The record in 17741 and 17742 is not a printed record but consists of the appendix attached to the intervenors' brief. The record in 17799 consists of the appendix to the petition. The record in 18180 is not a printed record but consists of a duplicate copy of various documents in two volumes filed on August 22, 1962 and a supplemental transcript of record filed on October 3, 1962.

The following is the crucial substance of the matters before this Court:

1. The order of July 31, 1961 has become and is final and binding upon the intervenors. This is so for several patent reasons: first, the time has elapsed for an appeal therefrom; second, the appeal taken therefrom has been dismissed by this Court; third, the intervenors exercised the leave granted by said order and filed an amendment to their pleading pursuant thereto, thereby accepting the benefits therefrom and being thereby estopped to attack it.

The force and effect of said order and all its

106
107
108
109
110
111
112
113
114
115
116
117
118
119
120

107

107
108
109
110
111
112
113
114
115
116
117
118
119
120

107

107
108
109
110
111
112
113
114
115
116
117
118
119
120

adjudication is binding upon intervenors. Said order fixed and limited the scope of the intervenors' intervention.

2. The only orders subject to review before this Court are then:

a. The order of January 10, 1962 directing Hartley to answer du Pont's additional interrogatories and requests for admissions which will compel the disclosure of trade secrets. This is subject to review by virtue of Hartley's petition for extraordinary writs pending in this Court in Cause No. 17799.

b. The said order of July 26, 1962 dismissing the said "Complaint in Intervention", the said order of the same day denying intervenors' motion for preliminary injunction and the said order of July 31, 1962 for final judgment (as amended) in effect dismissing the said "Complaint in Intervention". It is Hartley's position that the attempted appeal in 17741, subject to du Pont's said motion to dismiss and Hartley's said memorandum regarding the same, both numbered 17742, is moot since the attempted appeal related to the allegedly implicit and indirect adjudication by the said order of January 10, 1962 which was superseded by the explicit and unequivocal orders of July 26, 1962 dismissing the said "Complaint in Intervention" and denying the intervenors' said motion for preliminary injunc-

tion and on July 31, 1962 by the said order for final judgment.

The only pleading by intervenors before this Court is their said "Complaint in Intervention" and the only orders are the said orders indicated in the last two paragraphs. (Their said motion for preliminary injunction is dependent upon said complaint.)

The real point is not whether the intervenors have been permitted to intervene (they have been) but the scope and extent of their intervention. They deliberately and continuously confuse the fact that they have been repeatedly permitted to intervene, that they have accepted the leave granted by the District Court, by its orders which have become final, to intervene in a specified manner but although accepting the leave under said orders they have attempted to intervene differently and beyond the scope of the said orders.

Reduced to the ultimate issue, the proposition for this Court to determine is whether or not the intervenors are entitled to fix the manner of their intervention or whether they are bound, first, by the said orders which have become final, and, second, and in any event, by the historical, traditional, statutory and constitutional limits to the right of intervention.

It is Hartley's position that intervention means precisely that. It is inherent in the connotation of

judgment.

The court, in its opinion, stated that the

plaintiff's claim was based upon the

contract entered into between the

parties on the 15th day of July, 1911.

The court found that the

plaintiff had performed all the

obligations of the contract and

was entitled to the amount of

the contract price, less the

amount of the discount allowed

to the defendant.

The court accordingly granted

judgment in favor of the

plaintiff for the sum of

the contract price, less the

amount of the discount allowed

to the defendant.

The court also granted

judgment for the costs of the

suit.

The court's opinion was

affirmed by the court en banc.

The court's opinion was

affirmed by the court en banc.

intervention that it is an entry into a pending action between other parties, the issues of which have already been framed. It does not permit an entirely different, separate and distinct case to be injected into the pending action. Otherwise it would not be intervention but a different action.

Hartley points out that this confusion by the intervenors was anticipated by it in its serious and strenuous efforts to have this Court define and clarify this matter in Cause No. 16140 when this Court held that Formulabs had the right to intervene regarding the pending discovery proceedings between Hartley and du Pont in the main action. It will be recalled that Hartley was greatly concerned that Formulabs might contend that this Court's decision in 275 F.2d 52 (that the order denying it the right to intervene was erroneous) gave it carte blanche to intervene in any manner it saw fit or, more specifically, by intervening to seek an injunction against Hartley on an entirely different basis and cause of action and upon issues different from those framed between Hartley and du Pont in the main action. Hartley seriously submitted this to this Court in its petition for rehearing in 16140 and in its petition for certiorari to the Supreme Court.

What Hartley then feared has come to pass since intervenors now argue that they have carte blanche

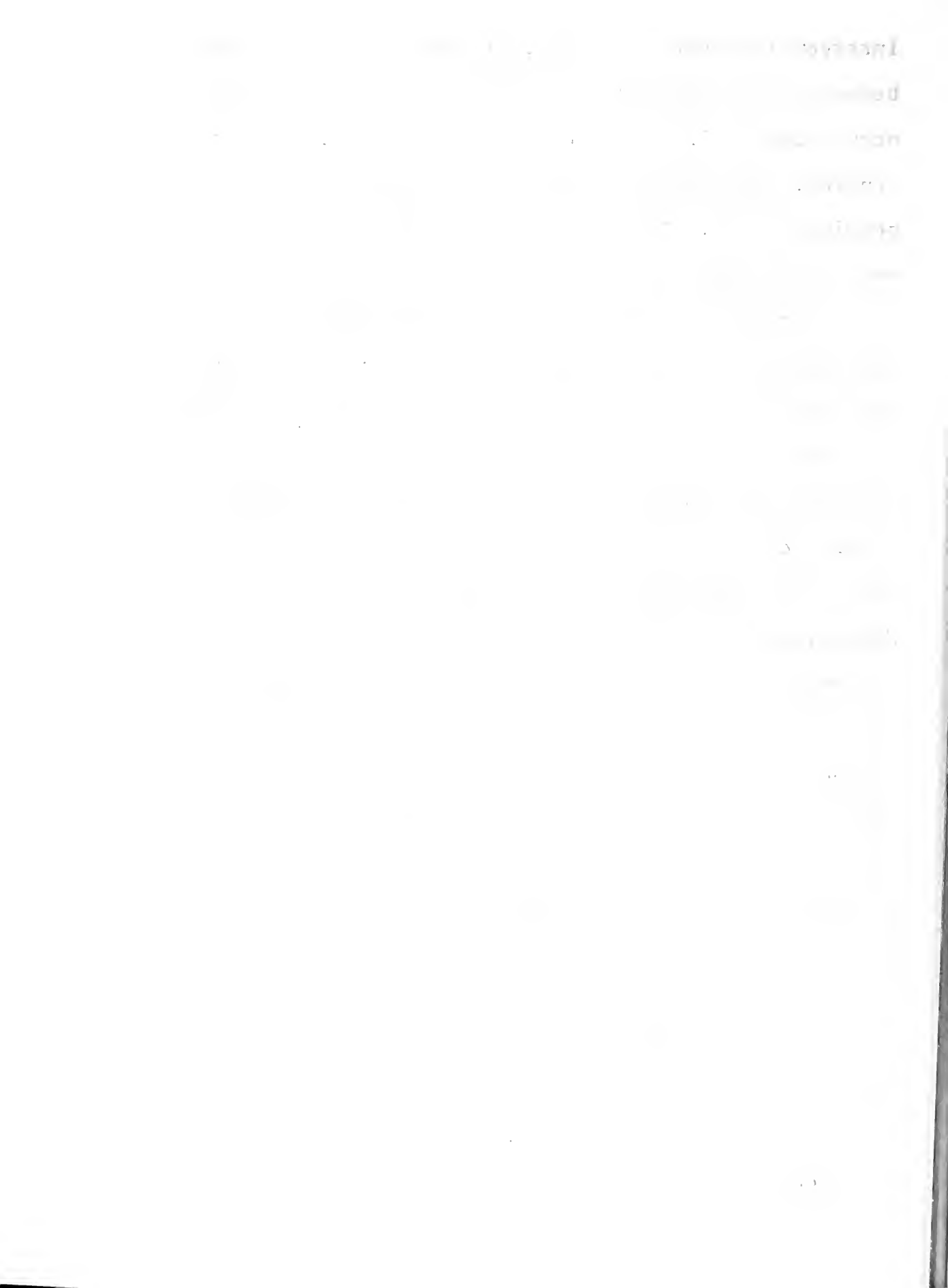

right to file an entirely different case within the main action and to have it litigated within the main action although there is no other ground of federal jurisdiction.

It is Hartley's position that not only has the intervenors' right to intervene been unequivocally and explicitly fixed and defined by the final order of the District Court (of September 11, 1961 dated as of July 31, 1961 and entered September 21, 1961, as noted supra) but also by the traditional and historical concept of intervention.

Parties seeking to intervene take the pending action as they find it. Otherwise they should not intervene and cannot intervene and should be required to litigate their different, separate and distinct cause of action as all other litigants do.

The intervenors' whole (and sole) position is predicated upon this Court's decision in 275 F.2d 52 as having allegedly held that under FRCP 24(a)(3) Formulabs (and the other intervenors through and with it) had the right to intervene by the original cross-complaint, the sufficiency of which this Court allegedly upheld. To state it differently, the intervenors' position is that by holding that Formulabs could intervene and by reversing the order denying its motion to intervene, supported by its original cross-complaint, this Court, in

right to life, liberty and property
of the people of the State of New York
and to the enjoyment of the same
without any unreasonable interference
with their right to privacy.

The Court has held that the right to privacy
is a fundamental right which is
protected by the Constitution.
The right to privacy is not a
right to be left alone, but a
right to be free from unreasonable
intrusions into one's private life.

The right to privacy is a right
which is not explicitly mentioned
in the Constitution, but which
is derived from the Bill of Rights.
The right to privacy is a right
which is not absolute, but which
is subject to reasonable regulation
by the State.

The right to privacy is a right
which is not a right to be left
alone, but a right to be free
from unreasonable intrusions
into one's private life.
The right to privacy is a right
which is not absolute, but which
is subject to reasonable regulation
by the State.

The right to privacy is a right
which is not a right to be left
alone, but a right to be free
from unreasonable intrusions
into one's private life.
The right to privacy is a right
which is not absolute, but which
is subject to reasonable regulation
by the State.

275 F.2d 52, also held that the cross-complaint was a sufficient pleading which adequately set forth "the claim or defense for which intervention is sought" under FRCP 24(c). In Hartley's opposition to the intervenors' contentions on said appeal it, among other things, contended that the cross-complaint was insufficient as a pleading and did not satisfy FRCP 24(c). This Court did not rule on this.

Hartley's position is that this Court's opinion in 275 F.2d 52 merely held that Formulabs could intervene regarding the only proceeding as to which intervention could be proper, in any event, and regarding which proceeding intervention was only sought, i.e., the discovery proceeding by du Pont which involved disclosure of a certain secret formula; and that any other implied holding by this Court would not only be obiter but would be unjustified. This appears clear from this Court's careful language in its said opinion, including the following, "Section (c) of the rule deals with procedure. Since no problem of procedure is involved, we will not quote the provisions of section (c)." Further, during the oral argument before this Court on March 4, 1962 in Cause No. 17741 (and 17742), comments were made by Judge Barnes and Judge Jertberg to the substantial effect that the intervenors were granted leave to intervene regarding the situation and status of the

| | |
|------------------------------------|---|
| Introduction | 1 |
| Chapter I. General Information | 1 |
| Chapter II. Administration | 1 |
| Chapter III. Instruction | 1 |
| Chapter IV. Physical Education | 1 |
| Chapter V. Vocational Education | 1 |
| Chapter VI. Special Education | 1 |
| Chapter VII. Buildings and Grounds | 1 |
| Chapter VIII. Finance | 1 |
| Chapter IX. Miscellaneous | 1 |
| Appendix | 1 |
| Index | 1 |

main action as it then existed.

The fact should never be forgotten that the intervenors' sole basis for intervention, repeatedly conceded by them, is the pending disclosure order on du Pont's discovery proceedings.

The intervenors have repeatedly stated that the issues between them and Hartley are separate and distinct from the issues between Hartley and du Pont in the main action. Reference is made to Hartley's motion to dismiss the appeal in Cause No. 17598, specifically the statement of facts, pages 8-11 inclusive. Therein Hartley quoted statements made by Formulabs in its reply to du Pont's response to Formulabs' request for clarification filed on June 23, 1961 (statement of facts, pages 8-9) (this does not appear in the designation of record in 17598), the intervenors' statements in their memorandum in support of their motion to intervene as cross-complainants (pages 10-11 of said statement of facts) (this appears in the designation of record in 17598, page 27).

Formulabs said, among other things, in its said reply to du Pont's response to its request for clarification (page 2, lines 2-10) the following (which appears in said statement of facts, pages 8-9):

"The basic issue between Hartley and du Pont is: Can du Pont show good cause

justifying an order for discovery against Hartley?

"The basic issue in any action brought by Formulabs is: Does Formulabs have the right to enjoin Hartley from disclosing to another a secret given in confidence?

"Formulabs has no contest with du Pont. The two issues are separate. They are not properly combined and the Formulabs argument is not useable against du Pont as suggested by du Pont in the quotation above."

(On page 2, lines 19-22):

"To order Formulabs to intervene at this time in the absence of an order injurious to its position, or which it recognizes as dangerous, is to insist that a third party take part in litigation unnecessarily."

In the said memorandum the intervenors said the following (designation of record in 17598, page 27):

The said memorandum stated that intervenors wanted "to make it crystal clear that they join neither plaintiff nor defendant in the main action and become a 'co-party' with neither. Instead they enter

the case to assert an independent property right in accordance with their rights" as set out in Formulabs v. Hartley, 275 F.2d 52.

They quoted FRCP 13(g) defining a "cross-claim" and stated:

"It is not believed that pleading in the present instance falls within that rule" because (1) "it is not a pleading by 'one party against a co-party' . . . Intervenors have no 'co-party'. They are aligned with neither plaintiff nor defendant. They seek to assert a right against plaintiff but in no sense are they aligned with defendant. A right is asserted against plaintiff. Certainly then plaintiff is not a 'co-party'. Instead plaintiff stands in the position of a defendant so far as intervenors are concerned"; (2) the cross-complaint does not assert "a claim . . . arising out of the original 'transaction or occurrence'. Intervenors' rights of ownership are entirely independent of, and existed long before, the transaction giving rise to the suit" between Hartley and du Pont; (3) the cross-complaint does not relate to any "property

THE UNIVERSITY OF CHICAGO

PHYSICS DEPARTMENT

PHYSICS 311

LECTURE 1

MECHANICS

1.1 Kinematics

1.2 Dynamics

1.3 Energy

1.4 Momentum

1.5 Angular Momentum

1.6 Oscillations

1.7 Waves

1.8 Relativity

1.9 Quantum Mechanics

1.10 Statistical Mechanics

1.11 Thermodynamics

1.12 Electromagnetism

1.13 Optics

1.14 Modern Physics

1.15 Miscellaneous

1.16 Problems

1.17 Experiments

1.18 History

1.19 Bibliography

1.20 Index

1.21 Appendix

1.22 Glossary

1.23 Acknowledgments

that is the subject matter of the original action", which is du Pont's defective dye; that the "most important" fact is "that intervenors seek to assert a new right forming no part of the main case and in the assertion of which they join neither plaintiff nor defendant".

Regarding FRCP 7(a) they stated that "it is rather clear that a situation in which an intervenor intervenes in a suit solely to protect a property right and not as a party to the main action was not in the contemplation of the drafters of the rules at the time this wording was adopted. None of the pleadings referred to in that rule or in 13(g) fit the present case".

The intervenors also stated in their "Objections to Proposed Order re Intervention as Proposed by Plaintiff Hartley Pen Company", dated September 5, 1961 (which appears in the said designation of record in 17598, page 255) the following:

"4. The defendant du Pont seeks to learn the secret upon grounds having nothing to do with ownership rights or intervenors' rights as owners.



"5. If intervenors are compelled to oppose du Pont upon questions having nothing to do with intervenors' rights as owners to protect their property, they are being deprived of their day in court upon the only issue with which they are at all concerned."

* * *

"Intervenors are not interested in du Pont's procedural rights and du Pont is not interested in intervenors' rights of ownership.

"To force intervenors to lay aside all effort to enforce their right of ownership and to compel them to contest a procedural question cannot be right."

They also stated in their "Memorandum and Points and Authorities in Opposition to the du Pont Motion to Dismiss Complaint in Intervention", dated September 5, 1961, which is not in the record of any of said proceedings, the following:

"7. Intervenors have no quarrel with defendant du Pont and the merits of its case with respect to plaintiff Hartley do not concern intervenors except to the extent they would prefer to see licensee

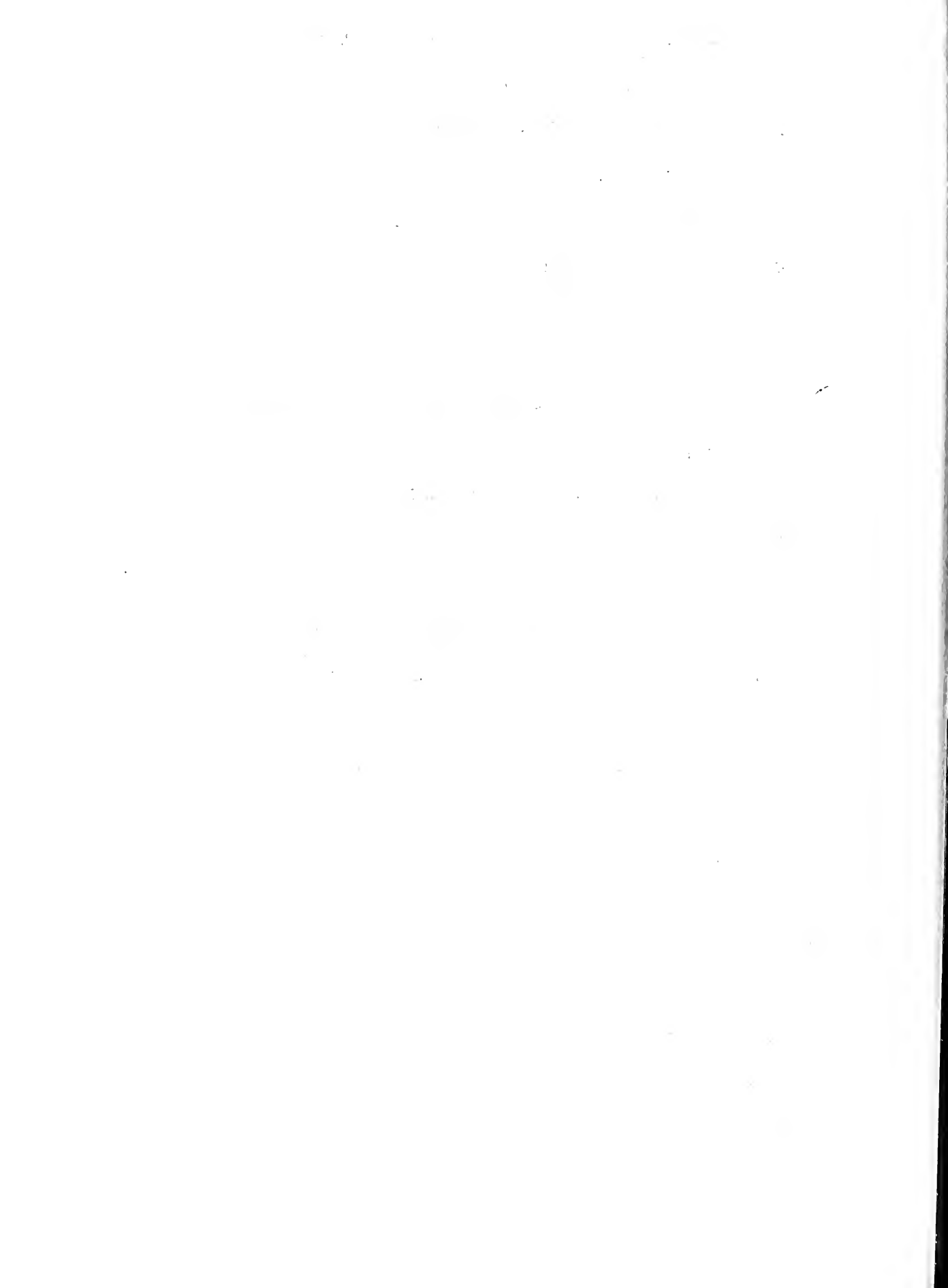

Hartley prevail.

"8. Whether or not du Pont can or cannot show good cause justifying, as between it and Hartley, an order to disclose is actually of no concern to intervenors."

* * *

"H. Why should an intervenor interested only in protecting his unique property in the hands of the plaintiff be forced by the Court to join that plaintiff in asserting plaintiff's rights against the defendant, or in opposing defendant's rights against the plaintiff, on a discovery question in which it has no interest?"

Accordingly, the intervenors' only interest and only right, if any, is to participate and intervene regarding the discovery proceedings initiated by du Pont's additional interrogatories and requests for admission.

These discovery proceedings are the very subject of Hartley's petition in Cause No. 17799.

This Court held in 275 F.2d 52 "The sole issue on this appeal is whether the district court erred in denying Formulabs' motion to intervene". Again, it

1907

1907

1907

1907

1907

1907

1907

1907

1907

1907

1907

1907

1907

1907

1907

1907

1907

1907

1907

1907

1907

1907

1907

1907

1907

said that the issues were further narrowed since Formulabs conceded that it only could intervene under Rule 24(a)(3) and, again, that the issue was: did Formulabs have the right to intervene under 24(a)(3).

I

The Intervenors' Brief in Cause No. 17741

Preface

Since this related to a non-appealable order as to which du Pont's motion to dismiss is pending before this Court undetermined and since such order has been superseded by the subsequent orders which are the subject of the intervenors' appeal in this appeal 18180, the use of the intervenors' brief in 17741 is and should be limited only to those matters which are material in this appeal 18180.

[This brief is in three parts, A (3-18) the argument on said appeal, B, the argument as a petition for writs (19-46) and C, the argument opposing du Pont's motion to dismiss the appeal in 17741.]

A. The Argument on said Appeal

1. That the owner of a trade secret has exclusive right to it (6-8).

All the argument in this regard relates to the general rights of an owner of a trade secret against

1. The first part of the document discusses the importance of maintaining accurate records of all transactions.

2. It is essential to ensure that all data is entered correctly and that any discrepancies are identified and corrected promptly.

3. The second part of the document outlines the various methods used to collect and analyze data, including surveys, interviews, and focus groups.

4. The final part of the document provides a summary of the findings and conclusions drawn from the analysis.

5. The first part of the document discusses the importance of maintaining accurate records of all transactions.

6. It is essential to ensure that all data is entered correctly and that any discrepancies are identified and corrected promptly.

7. The second part of the document outlines the various methods used to collect and analyze data, including surveys, interviews, and focus groups.

8. The final part of the document provides a summary of the findings and conclusions drawn from the analysis.

9. The first part of the document discusses the importance of maintaining accurate records of all transactions.

10. It is essential to ensure that all data is entered correctly and that any discrepancies are identified and corrected promptly.

11. The second part of the document outlines the various methods used to collect and analyze data, including surveys, interviews, and focus groups.

12. The final part of the document provides a summary of the findings and conclusions drawn from the analysis.

13. The first part of the document discusses the importance of maintaining accurate records of all transactions.

14. It is essential to ensure that all data is entered correctly and that any discrepancies are identified and corrected promptly.

15. The second part of the document outlines the various methods used to collect and analyze data, including surveys, interviews, and focus groups.

16. The final part of the document provides a summary of the findings and conclusions drawn from the analysis.

17. The first part of the document discusses the importance of maintaining accurate records of all transactions.

18. It is essential to ensure that all data is entered correctly and that any discrepancies are identified and corrected promptly.

19. The second part of the document outlines the various methods used to collect and analyze data, including surveys, interviews, and focus groups.

20. The final part of the document provides a summary of the findings and conclusions drawn from the analysis.

21. The first part of the document discusses the importance of maintaining accurate records of all transactions.

22. It is essential to ensure that all data is entered correctly and that any discrepancies are identified and corrected promptly.

23. The second part of the document outlines the various methods used to collect and analyze data, including surveys, interviews, and focus groups.

24. The final part of the document provides a summary of the findings and conclusions drawn from the analysis.

the world, not to the licensor's rights and obligations as to his licensee and the latter's rights and obligations. Particularly not as to the licensee's rights to use the trade secrets knowingly in product manufacture and the right to use those trade secrets if necessary in enforcing their rights to products manufactured by it or to defend product liability cases arising out of the use of the trade secrets in the manufacture of the products. This is inherent in business and commerce and therefore was patently anticipated by Hartley and the intervenors.

It is not true that disclosure under a safeguarded discovery order is the same as an unequivocal disclosure to a stranger. This is obvious. The intervenors make much of the fact that they disclosed the trade secret in confidence by contractual restraints and that this protected the trade secret. Disclosure with judicial restraints, by restraining orders and safeguards in a discovery order, is at least equal to, but apparently greater than, the contractual restraints. If disclosing a trade secret under a contractual restraint is not a publication neither is it by disclosing it under a judicial restraint in a discovery order.

Intervenors (6) make much of this Court's language in 275 F.2d 52 that Formulabs would be adversely affected by an order of the Court "requiring publication

of the trade secrets¹¹. This is a clear illustration of the intervenors' use of semantic expressions to extend the scope and effect of the ruling. It may be that this use of the language is most unfortunate, considered in retrospect. But the fact is that this Court was discussing generally the matter of publication of trade secrets and specifically was determining the effect of Judge Harrison's order, which contained no protective measure at all.

2. That the property owner has the constitutional right to assert his property rights in a court having jurisdiction of the property (8).

This, of course, is obvious. But it begs the question. Owners have constitutional rights to due process but due process has defined procedural requirements.

The intervenors repeatedly stress their property rights.

What about Hartley's property rights and constitutional rights regarding them?

3. That intervenors were given the right to intervene by this Court in 275 F.2d 52 (9-12).

That is true.

Intervenors state (9) that there is no question that they will be adversely affected by disclosure of the trade secrets and since there is no question of the right to intervene the only question left is whether the

... .. 30
... .. 30
... ..
... ..
... ..
... ..
... ..
... ..

... ..
... ..
... ..
... ..
... ..
... ..
... ..
... ..

... ..
... ..
... ..
... ..
... ..
... ..
... ..
... ..

... ..
... ..
... ..
... ..
... ..
... ..
... ..
... ..

... ..
... ..
... ..
... ..
... ..
... ..
... ..
... ..

the owner of property can be denied the right to assert ownership simply because he is an intervenor.

Hartley asks, would the intervenors be adversely affected by disclosure under the safeguards? It contends not. In any event, this is not the situation where a stranger is involved or someone having no contractual relationship and status as Hartley does. Hartley has rights under the contract between it and Formulabs. Stated otherwise, Formulabs anticipated, or should have anticipated, Hartley's use of the trade secrets in its product manufacturing utilizing the trade secrets and therefore could not be "adversely" affected, as against Hartley, although it might even be actually damaged (assuming no disclosure order with protective measures). There is a parity with the doctrine of volenti non fit injuria or non-compensable damages. The issue of fact and/or law that Hartley stands with and for Formulabs, and that Formulabs is estopped to question Hartley's use of the trade secrets as being anticipated, involves Hartley's right to question Formulabs' right to intervene in this action. Formulabs is not in the position of an owner opposing a stranger to its title or property. Hartley has rights and stands on parity, if not greater, rights with Formulabs.

The intervenors state, in substance, (9) an owner cannot be deprived of property without due process be-

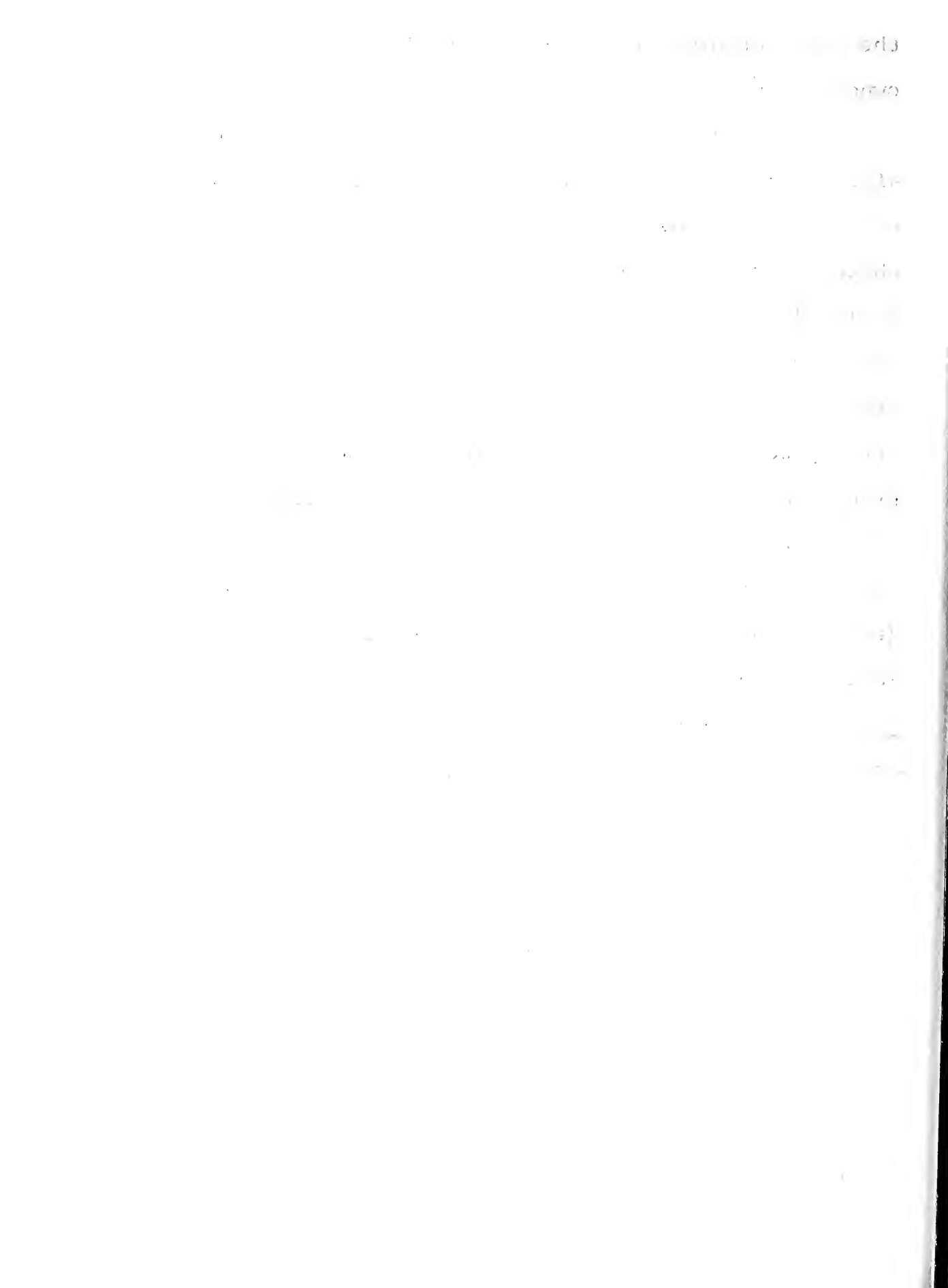

cause he is an intervenor. It is Hartley's position that patently no one should or can legally be deprived of his property without due process. Ironically, Hartley's rights here have been completely ignored not only by intervenors, du Pont, the district court, but this Court, at least in this regard. This is a complete lack of due process. Hartley has the right to contend that Formulabs' rights are relative and limited. It has been denied the opportunity and the right to assert these rights. It has always been assumed that Formulabs has unlimited rights against everyone, including Hartley. This is just not so. Should not Hartley be given the opportunity to litigate with due process its claims against Formulabs? Or is Formulabs beyond this?

The intervenors then state (9-10) that to make such contention is to "give primacy to procedural rights at the expense of fundamental property rights".

Hartley states that the key is the remedy to enforce the right. Formulabs insists on a tailor-made remedy having no precedence or authority. It certainly has rights, but so does Hartley. Each should litigate them. The federal court has no jurisdiction of an independent suit between one party to the main action and a stranger to it. The right to intervene is one thing. But to litigate a non-federal cause of action (properly triable in the state courts) in the federal court be-

cause of expediency or alleged inadequacy of remedy is another. Rights cannot be created to afford remedy. It is vice versa. Remedies, assuming that it is still true (and proper, disciplined applications within the federal jurisdiction, scope and grounds are made) that for every right (since every wrong presupposes the violation of a right) there is a remedy, the remedy may be modified to meet the needs of the occasion or the particular suit. Such as enjoin the disclosure and further discovery proceedings relating thereto until Hartley and the intervenors litigate the controversy in the state court where it properly belongs.

The intervenors cite cases (10). Most of these were considered by Hartley in its brief in Cause No. 16140. In any event, each and all of these cases involved ancillary proceedings in the main action, which were dependent thereon. This is entirely different from the intervenors' pending appeal. No useful purpose will be served by discussing the facts and the holdings in each of the cases cited by the intervenors. This Court is familiar with them. The intervenors unduly emphasize and attempt to expand Krippendorf v. Hyde, 110 US 276. This held that intervention is permitted to allow strangers claiming an interest in the subject matter of the main action, to assert their titles and rights there-to. Krippendorf involved a suit for goods sold by

1870
1871
1872
1873
1874
1875
1876
1877
1878
1879
1880
1881
1882
1883
1884
1885
1886
1887
1888
1889
1890
1891
1892
1893
1894
1895
1896
1897
1898
1899
1900

plaintiff to defendant. Plaintiff levied an attachment on a third person's goods in another city claiming they were defendant's. The third person furnished a bond, the goods were delivered to him and sold. He then moved to intervene and was made a defendant. Plaintiff moved to strike him out as a defendant and the motion was granted. Defendant's creditors came into the suit. Judgment was rendered for plaintiff and the creditors. The marshal was ordered to execute. The third person filed a bill to restrain the marshal but the trial court dismissed it for want of equity, holding there was a plain remedy at law. This was reversed as under the Indiana state practice the third person could not be made a party to test title; the only remedy he had was replevin in the state court but he could not maintain this since the property was in the custody of the United State marshal, This was a direct claim of title and there was a direct interest in the subject matter. The court held that the proceedings would be considered as an ancillary and dependent bill equivalent in effect and purpose to a petition in the attachment proceeding itself, as incident to and dependent on it. As a further example of the intervenors' confusion, the case they cite, Morgan's Company v. Texas Central Railway, 137 US 171, held that intervention is permitted in proper cases where no new and distinct matters are introduced by the intervention,

where the subject matter is the same and where the conflicting claims to the property which are the subject matter of the action can be determined.

4. That the order of January 10, 1962 ordered disclosure of the trade secrets which the intervenors seek to enjoin (12-13).

This discusses the alleged appealability of the order. This is no longer pending but is moot since the intervenors have appealed from subsequent appealable orders.

5. That said order was a denial of the motion (14-15).

The intervenors' discussion is abstract, academic and unsound. In any event, the point is moot.

6. That the said order was appealable (15-17).

This is an extension of the intervenors' said argument and is similarly fallacious and moot.

7. That if the intervenors' appeal is defective it should be considered as a petition for extraordinary writs (17-18).

This is a further extension of said argument and is similarly fallacious and moot.

The substance of the intervenors' position is that they own property, they want to protect it and are entitled to do so under FRCP 24(a)(3).

Hartley submits the question: what rights of

where the subject was the only one of its kind

in the world. It was the only one of its kind

in the world. It was the only one of its kind

in the world. It was the only one of its kind

in the world. It was the only one of its kind

in the world. It was the only one of its kind

in the world. It was the only one of its kind

in the world. It was the only one of its kind

in the world. It was the only one of its kind

in the world. It was the only one of its kind

in the world. It was the only one of its kind

in the world. It was the only one of its kind

in the world. It was the only one of its kind

in the world. It was the only one of its kind

in the world. It was the only one of its kind

in the world. It was the only one of its kind

in the world. It was the only one of its kind

in the world. It was the only one of its kind

in the world. It was the only one of its kind

in the world. It was the only one of its kind

in the world. It was the only one of its kind

in the world. It was the only one of its kind

in the world. It was the only one of its kind

in the world. It was the only one of its kind

in the world. It was the only one of its kind

ownership do the intervenors actually have? Does not Hartley also have rights of ownership? Does not Hartley also have constitutional property rights to protect and the right to have them litigated and determined by due process?

B. The Argument as a Petition for Writs (19-46).

1. As to the intervenors' alleged purpose of intervention (22-3).

They (23) contend they have no interest "in the main action nor in the procedures relating thereto, nor as to whether du Pont can or cannot establish good cause as to justify, as between itself and Hartley, the right to see the trade secrets. That good cause may exist in great quantities but if the trade secret belongs to Intervenor they have the right to protect it against the world".

Hartley submits the following: The statement is not correct. The intervenors have no right to "protect" the secret against Hartley and more specifically no right to "deprive" Hartley of its right to use the trade secret to give it the full benefit of its license to use it in its manufacture of its end product which was always known to the licensor. The license does not stop with the manufacture of the product. It is monstrous to contend that Hartley can use the trade secret to make

10/10/10

10/10/10

10/10/10

10/10/10

10/10/10

10/10/10

10/10/10

10/10/10

10/10/10

10/10/10

10/10/10

10/10/10

10/10/10

10/10/10

10/10/10

10/10/10

10/10/10

10/10/10

10/10/10

10/10/10

10/10/10

10/10/10

10/10/10

the product but cannot use it to enforce its use of the product. The intervenors have repeatedly stated that the trade secret is worth a million dollars. As Hartley has variously pointed out, many in the industry, including Hartley's competitors, know the trade secret by virtue of similar licenses given by Formulabs. It is practically common knowledge. As du Pont has variously stated, it may very well be that the trade secret is not a trade secret at all. However, Hartley's damages exceed the million dollars many times. Its very existence was jeopardized by its damages sustained from the defect of dyes and it has lost its pre-eminent position in its field as a proximate result thereof. There is a serious question, and Hartley has so raised it, whether the trade secret, so called, is worth a million dollars. Everyone appears to have lost sight of the fact that it has been assumed, as a practical matter, that the intervenors have full rights to enjoin Hartley from disclosing. This necessarily involved the assumption that Hartley has no rights at all. Talk about due process! Hartley has been given no opportunity at all to enforce its rights to the trade secret and its use of it. This is a classic case of confusion. Instead of Formulabs (the licensor) being required to prove that it has the right to enjoin Hartley from disclosing, it has been assumed, without pleading or proof

The project is due to be completed by the end of the year. The project is a major undertaking for the organization and will have a significant impact on our operations. The project is being managed by a team of experienced professionals who are committed to delivering high-quality results. The project is being funded by the organization and is expected to generate a positive return on investment. The project is being implemented in a phased manner to minimize disruption to our operations. The project is being monitored closely by the management team to ensure that it is progressing as planned. The project is expected to be completed by the end of the year.

at all, that it has. Instead of Hartley being given the opportunity to litigate its rights to the trade secrets and its complete use thereof, it has been assumed that it has no such rights. It is patent that the proper forum is the Los Angeles Superior Court in which Hartley has filed the declaratory relief action against the intervenors. The federal proceedings have been and can be stayed pending the determination of the superior court action. Hartley could have long ago disclosed in the main action (prior to this Court's injunction against it on February 2, 1962) with no other consequence than Formulabs' suit, if any, to claim damages therefor. Despite the patently well-nigh impossibility of Formulabs' being able to prove that disclosure of the trade secrets in the main action, under protective measures in protective orders, could or would cause it any damage, it could try it. It at least would have the opportunity to do so. And Hartley should have the similar right to litigate it. If it proved the full damages of \$1,000,000 as the alleged value of its alleged trade secrets (which are shared by numerous users and licensees) this would be a fraction of Hartley's damages, which it seeks to enforce in the main action. Accordingly, a speculative, practically impossible of proof damage claim is sought to be used to destroy a multi-million dollar claim of substantial merit. Instead of disclosing Hartley, how-

18 36

18 36

18 36

18 36

18 36

18 36

18 36

18 36

18 36

18 36

18 36

18 36

18 36

18 36

18 36

18 36

18 36

18 36

18 36

18 36

18 36

18 36

18 36

ever, performed all of its legal duties (and more). In appreciation of that, however, Formulabs seeks to destroy Hartley's main action. This is extreme disloyalty and unfairness.

2. Intervenors contend that their right to protect their property was adversely decided without being given their day in court and this constitutes an abuse of discretion and a violation of due process (31-45).

Hartley submits this question: what about Hartley's property rights in the trade secrets and the main action and its right to its day in court and its right to due process? To say that Hartley can dismiss the main action and thus avoid the whole matter is to deny it the right to fully use the trade secrets for which it has paid dearly and which it has established for Formulabs' benefit and the right to use the fruits of its licensed use of the trade secrets. It is fundamental that product litigation over product liability is inherent in the manufacture and sale of products. That should be and is anticipated by all connected with it. Formulabs anticipated and should have anticipated that Hartley would have lawsuits over its inks and would be required to disclose its trade secrets regarding them, either to enforce its rights including to the price of its inks, or to defend product liability actions against it.

Litigation is an inherent part of business today and is so recognized not only by the business world but by the courts and judicial notice has been taken of this fact.

Hartley submits that it is incredible that so much confusion and diversion has resulted from this case regarding intervention. Intervention is a participation in an already pending action as an incident to it and dependent upon it. It is not the joining in a pending action of an entirely different suit between different parties. This would not be intervention. It might be consolidation but not intervention. There is no authority for consolidation in a federal action of a non-federal case.

Hartley does not concede that disclosure under a discovery order, qualified with appropriate safeguards, would constitute a "publication", no more than telling employees of licensees or various licensees would be such a "publication" in a sense that it would destroy the trade secret. As Hartley has stated supra, the disclosure of a trade secret to a licensee, under contractual covenants, is no more (in fact not as much) protection against its publication and destruction than is its limited disclosure for discovery purposes only under a discovery order and judicial safeguards, consisting of protective orders.



As noted, supra, this Court's reference to "publication" in its decision in 275 F.2d 52 was clearly a general statement and in any event related to Judge Harrison's order which had no protective safeguards at all.

C. The Argument on du Pont's Motion to Dismiss the Appeal in 17741 (47-55).

Since the point is moot, as noted supra, and since much of the argument hereunder is repetitious and covered supra, Hartley will not extend this brief by further comment hereunder except to refer to its said memorandum regarding du Pont's said motion.

II

The Intervenors' Brief in Cause No. 18180

Preface

Intervenors state (2) that said brief is supplemental to, and supplemented by, the brief in 17741.

As Hartley has stated supra, this is not correct. Only that portion of the brief and record in 17741 which is relevant and material to the appeal in 18180 can be properly considered with the latter brief. The order which was the subject of the intervenors' appeal in 17741 was not an appealable order and is moot since subsequent orders were made from which this appeal has

been taken.

The intervenors state (2) the "basic issues" to be (a) their right to assert their property rights against Hartley and (b) their right to a preliminary injunction.

Hartley submits again the obvious fact that the controversy as to property rights between Hartley and the intervenors is not incidental to, or ancillary to, or dependent upon, the issues in the main action but is a strictly state court litigation between them alone.

It is not true, as intervenors state, under "Jurisdiction" (3), that the "Complaint in Intervention" was filed "under authority granted by this Court". This Court never authorized the filing of that complaint or any other complaint. It only reversed the order of Judge Harrison denying intervention and ruled intervenors could intervene. But how or by what pleading it did not decide. There was no pleading issue before this Court and this Court did not determine any pleading issue.

The "Statement of the Case" (5-7).

Among other things, intervenors state (6) that the dismissal of their "Complaint in Intervention" raised two concepts, one held by the district court, Hartley and du Pont and the other by intervenors, the first, that intervenors cannot fully assert their rights of

ownership and the second, that the intervenors have the right "to intervene to assert fully their property rights", otherwise their property would be taken without due process.

As to the first, Hartley submits that the statement is incorrect. The point is how, where and when do the intervenors enforce their rights. They have the right to do so in the state court, which has jurisdiction of their cause of action, if any, against Hartley. Then Hartley also has rights, which it has the right to enforce, and which it has tried to enforce in the declaratory relief action in the Los Angeles Superior Court.

The second statement is also incorrect. Everyone is entitled to enforce his legally cognizable rights by due process. But this means due process according to established principles, traditions and practices. The intervenors' position is not that they were not accorded due process (since it is patent that they have by their pleadings, proceedings and appeals) but that they insist on selecting and creating a special procedure, not recognized in the law, for enforcing what they consider to be their rights.

Intervenors state (7) that the district court denied their motion for a permanent injunction on the basis that they had no right to assert their property rights against Hartley. That is not so. The district court's

decision was based upon its conclusion that the intervenors had no right to attempt to enforce their claims in the form and manner in which they sought to do so in the main action and that if they wanted to intervene they should "intervene" and not attempt to "inject" a new cause of action and, in effect, attempt to "consolidate" a state case with a federal case in a federal court.

The Specifications of Error (7-9).

The substance of the intervenors' specifications of error is as follows: that it was error to dismiss their "Complaint in Intervention" and to deny their motion for preliminary injunction on the ground that the court had no jurisdiction of the cause of action alleged in the complaint and that the motion for preliminary injunction did not state sufficient grounds and also fell with the complaint. The rest of the intervenors' specifications are sheer argument and surplusage, i.e., that the court failed to follow the law of the case as this Court allegedly established it in 275 F.2d 52 and refused to accept that decision as res judicata, that the court erred in holding that disclosure under the disclosure order, with its effective provisions, was not a publication of the trade secret and would not irreparably injure intervenors and in also holding that du Pont's

1. Introduction

2. Methodology

3. Results

4. Discussion

5. Conclusion

6. References

7. Appendix

8. Acknowledgments

9. Contact Information

10. Author Biographies

11. Declaration of Interest

12. Funding Sources

13. Index

14. Glossary

15. Bibliography

16. Appendix A

17. Appendix B

18. Appendix C

19. Appendix D

20. Appendix E

21. Appendix F

22. Appendix G

23. Appendix H

interest in the procedural discovery transcended intervenors' property rights in the main action.

The last two contentions require special comment. The first was conclusion of law 6 (4 App. Doc. No. 280, pp. 54-6). The second was conclusion of law 5 (4 App. Id.).

It should be recalled that the findings of fact, conclusions of law and the order on the motion for preliminary injunction were prepared by du Pont with complete disregard of the strict issues and contentions made by Hartley. Hartley strenuously objected thereto (4 App. Doc. No. 284, pp. 40-43) and also objected to the proposed order (4 App. Doc. No. 285, pp. 46-49). The intervenors also objected thereto (4 App. Doc. No. 282, pp. 14-25 and Doc. No. 283, pp. 26-35). Judge Mathes overruled said objections and signed the said findings, conclusions and order. It was Hartley's contention that the only proper findings of fact were the first four and also Hartley's suggested findings 5 and 6 and that the only proper conclusion of law was conclusion 1 and Hartley's suggested 2 and 3 (4 App. Doc. No. 284, pp. 40-43, Supp.Tr.).

It was further Hartley's contention that the court could only properly find that it had no jurisdiction of the complaint and that the motion for preliminary injunction fell with it and did not state sufficient

grounds for preliminary injunction and that it should accordingly dismiss the complaint and deny the motion and that the only proper findings and conclusions were to that effect only.

It is such careless procedure by du Pont that confuses the simple issues and has enabled the intervenors to make the contentions they have made since 1958 and which they are instantly making in this pending appeal.

It should be borne in mind that Hartley then moved to amend the findings, conclusions and order (4 App. Doc. No. 292, pp. 1-9, Supp.Tr.). Judge Mathes denied this motion (4 App. Doc. No. 296, pp. 10-11, Supp.Tr.).

Hartley submits that the only material issue for the court to determine was: should Hartley's motion to dismiss the complaint in intervention be granted upon the grounds stated, or any of them, and should the intervenors' motion for preliminary injunction be denied upon the grounds of the opposition thereto by Hartley and du Pont? The substance of this was, of course, whether or not the complaint in intervention stated a proper case of which the district court had jurisdiction, i.e., was it ancillary to and dependent upon the main action and properly a subject of intervention therein; further, did the motion for preliminary injunction, being dependent upon the complaint, fall with it and did it, in any event, not state sufficient grounds for a preliminary

injunction as Hartley and du Pont contended.

As to the intervenors' repeated contentions that they were denied due process because the court dismissed their complaint in intervention and denied the motion for preliminary injunction, Hartley submits that their contentions are patently without any merit at all. It is obvious that the court considered the complaint in intervention in passing upon and considering Hartley's and du Pont's motions to dismiss the same and that it also considered the merits of the intervenors' motion for preliminary injunction and Hartley's and du Pont's opposition thereto and that it not only considered them but decided them. This was due process. Due process does not depend upon favorable results but only upon the opportunity to be regularly heard according to established precedents. The intervenors have been given their right to be heard, a right which they have, in Hartley's opinion, greatly abused, since they initiated their intervention efforts in 1958.

As to the intervenors' argument that this Court's decision in 275 F.2d 52 established the law of the case and was res judicata to the extent that this Court approved the filing of the "Complaint in Intervention" and established the intervenors' alleged unequivocal and predetermined right to having a motion for preliminary injunction against Hartley granted in the main

action, this has been answered supra.

All this Court did was to decide that Judge Harrison's denial to the intervenors of the opportunity to intervene was error under the state of the record at that time. It should be recalled in this regard that Judge Harrison's disclosure order contained no protective measure at all. This Court explicitly refused to pass upon the merits of Formulabs' cross-complaint and Hartley's strong argument against its sufficiency and its contention said pleading did not comply with FRCP 24(c). Hartley's petition for rehearing to this Court specifically stressed this matter, expressing Hartley's apprehension that this would result in the intervenors' contention that they were given carte blanche right to intervene regardless of their ability or inability to state a proper case for intervention (an apprehension which has come to pass). Hartley's petition for certiorari to the Supreme Court also stressed this point.

Although it is Hartley's position that the findings of fact, conclusions of law, judgment and order (other than as submitted proper by Hartley) were not necessary and were improper, the fact remains that they do not aid the intervenors. It is not what those documents state but what their legal effect is that is important.

For instance, the use of du Pont's semantics in stating that their interest in the procedural process

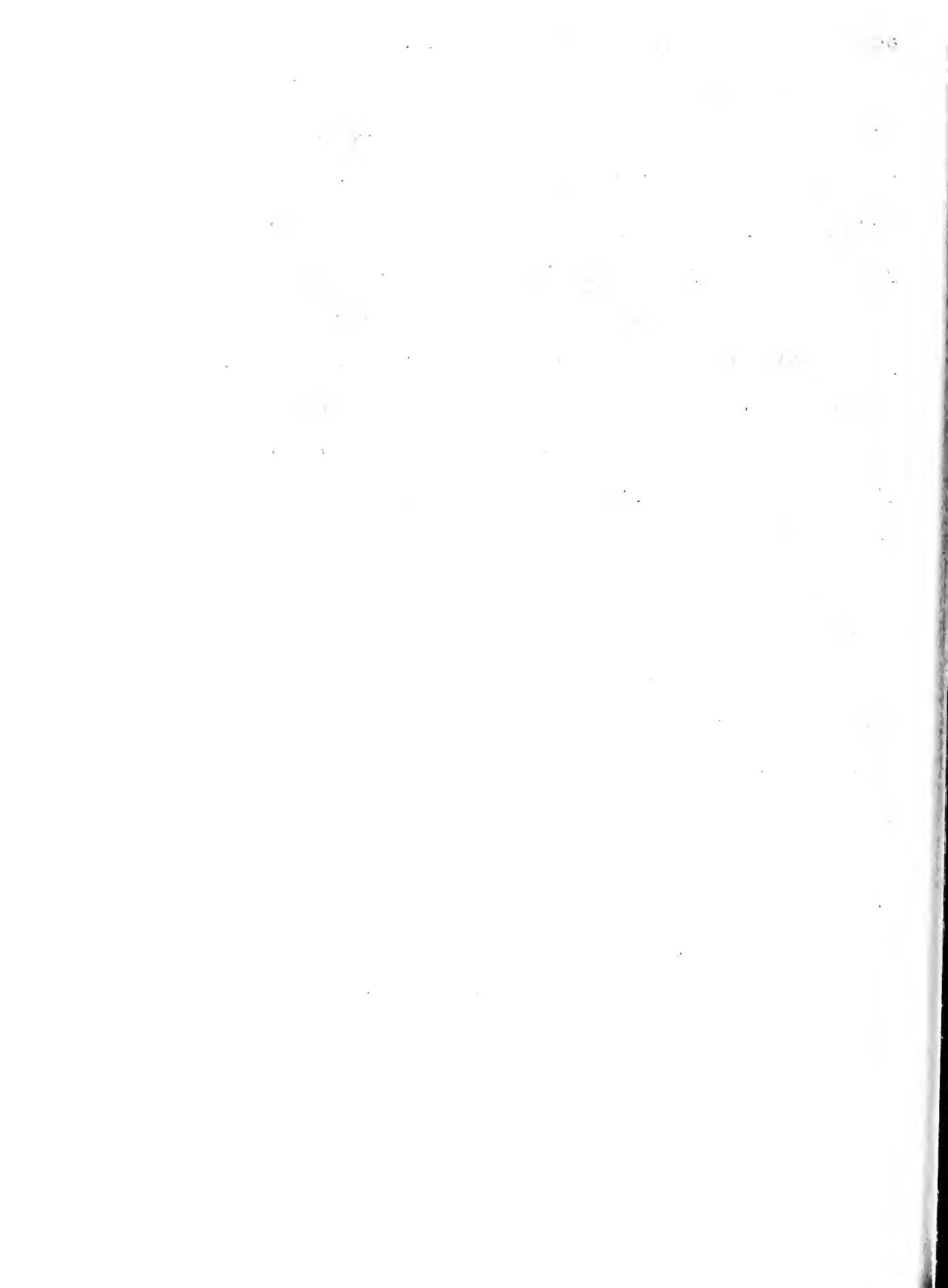

(whatever that means in this instance) "transcends" the intervenors' property right in the main action, is unfortunate but that is all. The fact remains that the intervenors do not have the right to intervene and inject their claims against Hartley in the main action. They have a right to enforce their claims against Hartley in the proper forum. The fact that du Pont added the irrelevant and unnecessary statement of transcension of comparative rights does not alter the results of the findings. The conclusion that disclosure under the disclosure order, with its protective measures, would not constitute the publication of the trade secrets so as to irreparably injure the intervenors was not necessary. However, it is correct. Disclosure under the disclosure order is not publication to the world and is more effective and more protective than the contractual provisions under which the intervenors are purporting to proceed against Hartley.

The Summary of Argument (9-11).

The summary of the intervenors' argument has been considered supra since it is only a recapitulation of the preceding contents of their brief.

Argument (12-35).

Preface

Faint, illegible text, possibly bleed-through from the reverse side of the page. The text is too light to transcribe accurately.

The intervenors incorporate specified portions of their brief in 17741. These have been considered supra. Further, only certain portions of that brief are relevant to this appeal.

1. That the court erroneously held that it had no jurisdiction.

The intervenors state (14) "The ownership rights of Intervenors are uncontested".

Hartley states that this is not so. Hartley has seriously questioned this, as noted supra.

They again contend that their right to intervene was established by this Court in 275 F.2d 52 and that the complaint therein was precisely the same as the complaint in this appeal. As noted supra, the pleadings are not the same; this Court did not pass upon the sufficiency or propriety of the original cross-complaint in cause 16140; the intervenors constantly ignore the fact that they are bound by the court's order granting them limited leave to intervene, which order has become and is final.

The intervenors contend (14-15) the court has limited their right so that first, they have been denied the right to assert their property rights, second, they have been prevented from asserting their ownership rights against Hartley, third, they have been compelled "to assert a defense in which they are not interested . . .

The first part of the report deals with the general situation in the country. It is noted that the economy is still in a state of depression, and that the government has taken various measures to stimulate it. These measures include the reduction of taxes, the increase of public works, and the improvement of the financial system.

The second part of the report deals with the situation in the various provinces. It is noted that the situation is generally similar, but that there are some differences. In some provinces, the situation is more favorable, while in others it is more unfavorable. The reasons for these differences are discussed in detail.

The third part of the report deals with the situation in the various cities. It is noted that the situation is generally similar, but that there are some differences. In some cities, the situation is more favorable, while in others it is more unfavorable. The reasons for these differences are discussed in detail.

The fourth part of the report deals with the situation in the various industries. It is noted that the situation is generally similar, but that there are some differences. In some industries, the situation is more favorable, while in others it is more unfavorable. The reasons for these differences are discussed in detail.

The fifth part of the report deals with the situation in the various sectors of the economy. It is noted that the situation is generally similar, but that there are some differences. In some sectors, the situation is more favorable, while in others it is more unfavorable. The reasons for these differences are discussed in detail.

The sixth part of the report deals with the situation in the various regions. It is noted that the situation is generally similar, but that there are some differences. In some regions, the situation is more favorable, while in others it is more unfavorable. The reasons for these differences are discussed in detail.

The seventh part of the report deals with the situation in the various countries. It is noted that the situation is generally similar, but that there are some differences. In some countries, the situation is more favorable, while in others it is more unfavorable. The reasons for these differences are discussed in detail.

The eighth part of the report deals with the situation in the various continents. It is noted that the situation is generally similar, but that there are some differences. In some continents, the situation is more favorable, while in others it is more unfavorable. The reasons for these differences are discussed in detail.

The ninth part of the report deals with the situation in the various oceans. It is noted that the situation is generally similar, but that there are some differences. In some oceans, the situation is more favorable, while in others it is more unfavorable. The reasons for these differences are discussed in detail.

The tenth part of the report deals with the situation in the various islands. It is noted that the situation is generally similar, but that there are some differences. In some islands, the situation is more favorable, while in others it is more unfavorable. The reasons for these differences are discussed in detail.

against du Pont, a stranger . . . which owes Intervenors no duty, which only wants to learn the secret in a suit it will win if it does not get the secret".

Hartley again submits that the crucial issue is whether what the intervenors are attempting to do is a true intervention or whether it is something else, i.e., a consolidation of a state action with a federal action in a federal court.

The intervenors continue their said contentions in referring (15-16) to conclusion of law 3 that du Pont has an interest in the discovery proceedings.

Hartley has discussed this supra. As it pointed out, even if the conclusion of law was improper and unnecessary, it does not aid the intervenors. The point still is whether the intervenors are properly intervening.

The intervenors then attempt to point out an alleged inconsistency between conclusions of law 3 and 4, 4 holding that the court had no jurisdiction to litigate the rights and obligations of Hartley and intervenors in the main action and 3 that the issue of the disclosure right involved du Pont's interests in discovery proceedings.

Hartley submits that, first of all, there is no inconsistency, the fact is obvious that du Pont has an interest in the discovery proceedings against Hartley

in the main action between them; secondly, the issue is clear, i.e., whether or not the intervenors are attempting to intervene properly or to inject an entirely new and different case and therefore, under the guise of intervention, effect a consolidation of a state case with a federal case in a federal court, although a state case is now pending between Hartley and the intervenors which will dispose of their controversy.

Intervenors discuss their rights in the trade secret (16-17). However, they ignore the fact that Hartley also has rights therein and very substantial and serious rights. And, more importantly, the right to due process in litigating them.

The intervenors state (17) that conclusion of law 4 would make it possible for Hartley to defeat the intervenors' rights to the trade secrets or their right to protect them by intervention or otherwise by merely denying that they own the property. This is non sequitur. The fact remains that Hartley has constantly contended, and does, that it has co-extensive if not superior rights to the intervenors in the trade secrets.

The intervenors state (17) that Hartley has not denied the intervenors' rights of ownership. This is incorrect. Hartley has, of course, conceded that the intervenors own, as licensor, the rights to the trade secret but that Hartley also owns, as licensee, the

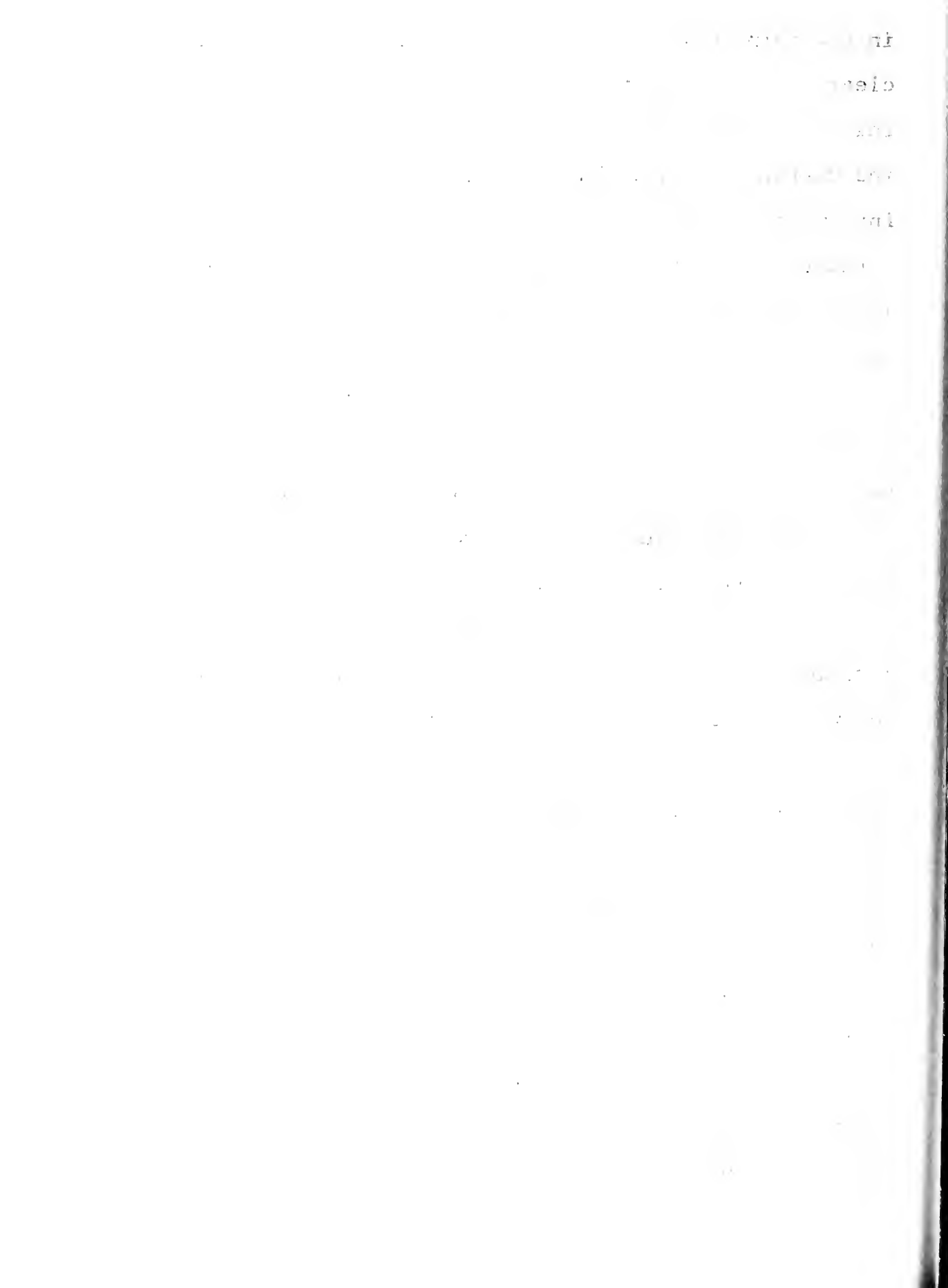

rights thereto and that these rights are very substantial and are such that they support and should support the main action, i.e., the cause of action for breach of warranty arising out of Hartley's use of the trade secrets under the license agreement. This has been variously discussed through all the causes before this Court and in the briefs and records therein and on this appeal.

The intervenors' argument as to jurisdiction (17-20) is undisciplined. Whether the district court has jurisdiction depends on the controversy sought to be submitted to it for its determination. It has, of course, jurisdiction of proper intervention but it does not have jurisdiction of new, independent and distinct state court action to be decided upon different issues and between different parties than the main action.

The intervenors confusedly argue (17-20) that no diversity is required to intervene under FRCP 24(a)(3) and that this was established by this Court in 275 F.2d 52.

Hartley admits that no diversity is required to intervene under 24(a)(3) under proper circumstances and upon a proper record. This is different from attempting to consolidate or inject a separate suit unrelated to the issues of the main action. This is different from attempting to force a trial of a state case in a federal case pending in a federal court. What the intervenors

10

11

12

13

14

15

16

17

18

19

20

21

22

23

24

25

26

27

28

29

30

want to do is to create a new ground of jurisdiction and they appear to be on their way to do so. This is a most serious and alarming development.

The intervenors then argue that their constitutional rights have been violated by the court's dismissal of their complaint in intervention and denial of their motion for preliminary injunction, i.e., holding that it has no jurisdiction. This argument has been considered supra and Hartley again points out that it also has constitutional rights which have been completely ignored and overlooked so far in all these proceedings.

2. That the court erred in holding that the intervenors could intervene only by joining Hartley against du Pont (21-24).

In the first place, the intervenors constantly overlook the fact that they accepted the leave fixed by Judge Mathes to intervene which defined the scope of the intervention, that the order has become and is final and that they are bound by it. This is not a direct attack against the order but a collateral attack which has no basis in law. They are bound and estopped by the order in attempting to intervene thereunder.

The key to the fallacy of intervenors' position and their violation of the basic concept of intervention, historically maintained and defined and unchangedly applied, is found in their statement (22) that "implicit"

in the court's orders and the "theory" purported to underline them is "that intervenors have no status in the action other than to take the pleadings as they find them. Any issue, any assertion of rights or position not having its origin in those pleadings is, in the district court's view, improper and outside the court's jurisdiction."

That is the precise doctrine of intervention and this is what intervenors completely ignore.

The intervenors state (22) that their intervention is a matter of right under 24(a)(3).

This, of course, does not mean that they can create new intervention proceedings and instead of intervening consolidate non-federal cases with federal cases in federal courts.

Intervenors state (22-23) that they have intervened to protect their property rights and that no issue involving the same is in the main action by the pleadings therein, and issues framed thereby, between Hartley and du Pont. Hartley submits this fact clearly shows the impropriety of the intervention.

If the intervenors' position is sound then all the fundamental principles of intervention, established historically, will be destroyed.

The usual intervention is where A sues B claiming the ownership of X property. B also claims ownership



of X property. C also claims ownership or interest therein and intervenes in the issues framed between A and B in the main action, i.e., who owns the X property.

It should be recalled that a judgment in the main action will not dispose of or adjudicate the property rights of, or controversies between, Hartley and the intervenors, as the intervenors have always conceded and as they concede in this appeal. The trade secrets are involved only under the discovery proceedings and the disclosure order. However, Judge Harrison's orders were without protective measures. Judge Mathes' order is with protective measures.

Unless this Court disciplines the intervenors' efforts and defines strictly the scope of its decision in 275 F.2d 52, it will establish the precedence that disclosure of a trade secret in discovery proceedings only, under safeguards fixed by the disclosure order, constitutes such a publication of the trade secret and such a disposition of property as to warrant intervention and that such a disclosure order would be the equivalent of a judgment upon the merits of the main case. This is not so and would destroy all fundamental principles of intervention.

Intervenors state (23) that the District Court has forced a procedural right upon them in lieu of their constitutional rights to protect their million

of
...
...

dollar trade secret.

Hartley submits this is not so; that the million dollar value has been denied; the trade secrets have been disclosed to many licensees in competition with Hartley and to many of the licensees' employees; that the disclosure will be made under protective measures; that the million dollar value should be compared with Hartley's claim for many times that amount involved in the main action.

The intervenors state (23) that they could have joined Hartley under 24(a)(2) but did not want to do so but intervene only under 24(a)(3); that their constitutional rights have been violated and due process denied them and that due process consists of an opportunity to be heard.

Hartley points out that the intervenors have had ample opportunity to be heard repeatedly since 1958. And they have been heard. This shows the fallacy and lack of discipline in the intervenors' position. They claim that due process consists of the opportunity to be heard and they have had nothing but opportunity to be heard. On the contrary, Hartley's rights in the trade secrets and its rights to use them in enforcing its cause of action in the main action has been completely ignored and it not only has not had an opportunity to be heard and to determine and

July

1900

1901

1902

1903

1904

1905

1906

1907

1908

1909

1910

1911

1912

1913

1914

1915

1916

1917

1918

1919

1920

1921

1922

1923

1924

litigate its controversy with the intervenors there-
over but it has been assumed that it has no such rights.

The intervenors again repeat their contention that the court's order that it has no jurisdiction of their "Complaint in Intervention" violated their constitutional rights and denied them due process.

Hartley again repeats that the very statement shows that intervenors have had due process, i.e., they have filed documents, have submitted them, the same have been heard, with the opposition thereto, by the court and decided. This is patently due process.

3-4. That the court erred in not following the "law of the case" and in refusing to accept, as res judicata, this Court's decision in 275 F.2d 52 (25-26).

The intervenors state (25) that the right "to intervene with a proposed complaint seeking the exact same relief sought by the complaint now dismissed was decided by this Court" in 275 F.2d 52; further, that "no attempt to justify the refusal" to follow the "law of the case" has been made; and that this Court "negatived the requirement of diversity of citizenship and held that the District Court did have jurisdiction."

Hartley submits that this is not so; that this Court merely held that Formulabs had the right to intervene but did not (nor could it without disapproving and not following established principles and

1

2

3

4

5

6

7

8

9

10

11

12

13

14

15

16

17

decisions regarding intervention) hold that diversity was not required for jurisdiction of a cause of action concededly not related to or incidental to the main action, independent thereof and between a stranger and one of the parties. All it held was that in proper intervention diversity was not required.

The intervenors state (25-26) that Formulabs' cross-complaint in Cause 16140 was directed solely against Hartley and sought injunctive relief, that this Court was aware of that fact and that the issue before this Court was the jurisdiction of the district court and that in making the order which is the subject of this appeal the district court failed to follow the "law of the case" as this Court declared it in 275 F.2d 52 that it had jurisdiction.

This is not so, as has been repeatedly noted supra. The issue was the right to intervene and not the question of jurisdiction over the subject matter of the cross-complaint in intervention or over the cause of action and controversy between Hartley and the intervenors.

The intervenors then state (26) that they stand with Formulabs "and upon entering this case of necessity took it as they found it".

The intervenors are completely inconsistent. They claim they do not have to take the main action as

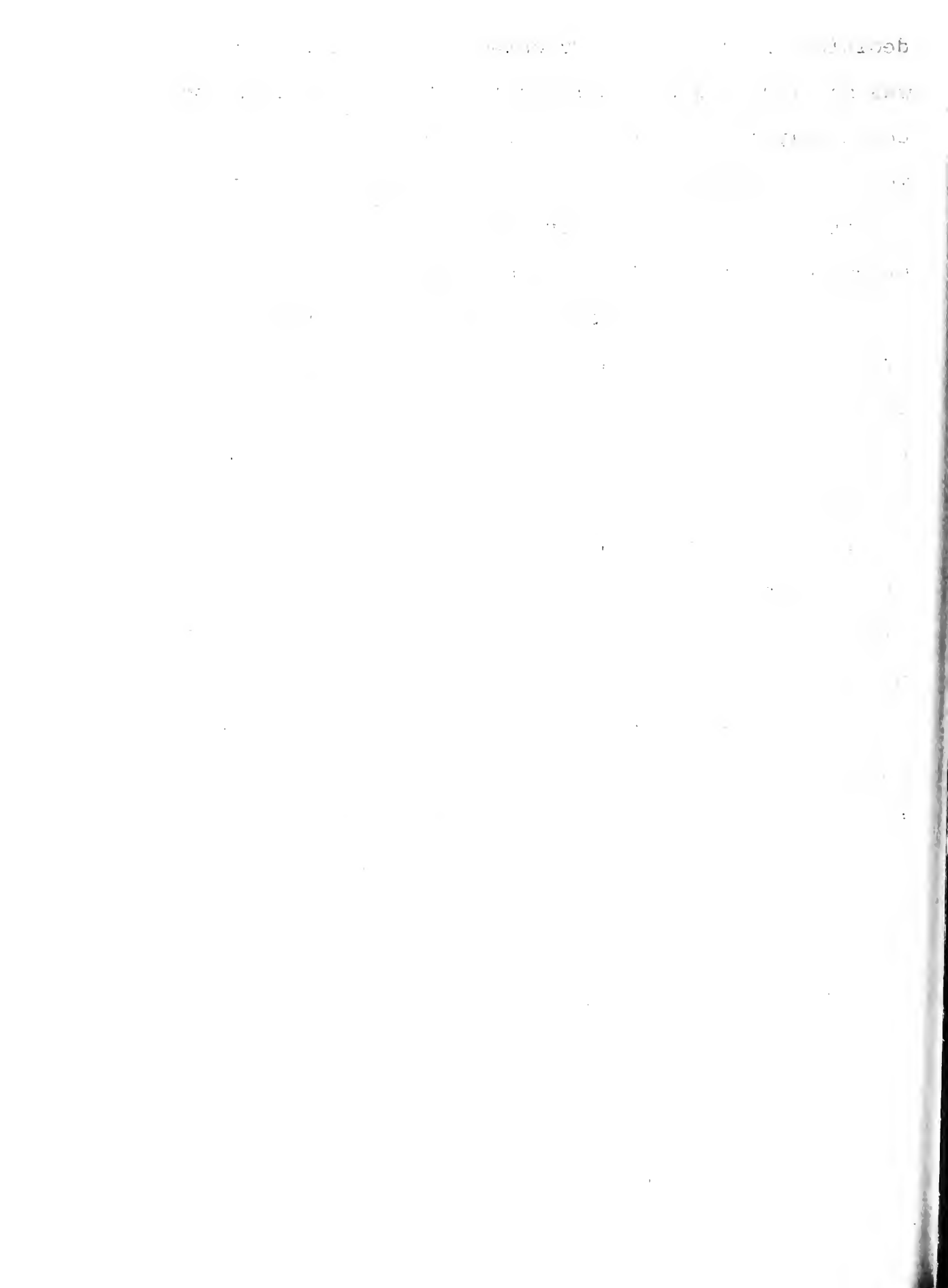

they find it on the issues framed in it between Hartley and du Pont but they do have to take it as they find it insofar as Formulabs' right to intervene is concerned!

The intervenors then state (26) no one objected in 16140 that the cross-complaint was "improperly directed against Hartley alone", that this could have been raised and the decision of this Court became res judicata upon that issue.

This is a completely incorrect statement of the record. Hartley not only objected but emphasized the absurdity of the contention that Judge Harrison could order disclosure (Formulabs so stated) and could then, at Formulabs' request, order Hartley not to obey his own order to disclose! Hartley repeatedly contended that the intervention in that form was improper and that the proper intervention was to join it opposing du Pont's disclosure efforts. Hartley further contended that it had substantial rights in the trade secrets and the right to use them effectively in order to enforce its cause of action involved in the main action and that Formulabs should proceed against du Pont.

The intervenors argue again that this Court's decision in 275 F.2d 52 is res judicata.

Hartley submits again that if it is res judicata then Hartley has been deprived completely of due process,

it has not had the opportunity to determine its controversy with the intervenors, it has been assumed that it has no right but that only the intervenors have rights to the trade secrets. Further, the intervenors completely ignore the distinctions between orders and judgments as to res judicata. Orders change with changing circumstances. Further, also completely ignored, is this Court's care in limiting the scope of its decision in 275 F.2d 52. Intervenors' argument, of course, also ignores Hartley's contentions in its petition for rehearing and its petition to the Supreme Court for hearing in 16140, noted supra.

As to the intervenors' contentions regarding the "law of the case".

In cause 16140 Formulabs had not intervened. It had been denied the right to do so. That appeal involved the sole issue: whether Formulabs should be allowed to intervene as to the only matter in which it was interested, i.e., du Pont's discovery proceedings seeking a disclosure of the trade secret. Formulabs conceded, as it had to, that it had no other interest in the main action and would not be affected by it at all. Accordingly, the sole reason for any intervention was du Pont's discovery proceedings. This Court held that Formulabs had the right to intervene in that regard. However, it explicitly refused to determine

It has been found that the...

very few of the...

to have...

with...

roughly...

there...

that...

the...

the...

of...

the...

the...

the...

the...

the...

the...

the...

the...

the...

the...

the...

the...

the...

the...

the...

the...

the...

the...

the sufficiency of Formulabs' pleading, i.e., its cross-complaint. It should be recalled that Judge Harrison denied Formulabs' motion to intervene.

In this appeal, 18180, Judge Mathes granted the intervenors' motion to intervene and granted them leave to do so in a limited manner. There is no question in this appeal of the right to intervene. Judge Mathes' order granting such leave has become final, the intervenors are bound thereby and limited by the scope thereof, i.e., to join Hartley in opposing du Pont's said discovery proceedings. In 16140, both in the district court and in this Court, Hartley conceded the sole basis for intervention was said discovery proceedings. However, although accepting Judge Mathes' leave by his said order and purporting to act thereunder, the intervenors are not seeking to intervene according to said leave but entirely differently. As Hartley has pointed out, they are not seeking "intervention" but "injection" of a new, distinct, state case into the federal main action, an unprecedented procedure, being really an attempt to effect a "consolidation" of a state case with a federal case in the federal court.

Accordingly, the causes are different and involve different questions.

The pleading in this appeal, i.e., intervenors'

the subject of the letter is the
condition of the road and the
desire to have it improved.

The road is in a very poor
condition and it is necessary
to have it repaired.

The road is in a very poor
condition and it is necessary
to have it repaired.

The road is in a very poor
condition and it is necessary
to have it repaired.

The road is in a very poor
condition and it is necessary
to have it repaired.

The road is in a very poor
condition and it is necessary
to have it repaired.

The road is in a very poor
condition and it is necessary
to have it repaired.

The road is in a very poor
condition and it is necessary
to have it repaired.

The road is in a very poor
condition and it is necessary
to have it repaired.

"Complaint in Intervention", is different from Formu-
labs' cross-complaint in 16140. This Court did not
pass upon the sufficiency of the latter pleading in
16140. It refused to do so and explicitly so stated.
Further, there was no final order granting leave, or
any order granting leave, in 16140. There is such an
order in this appeal, 18180.

"Normally the 'law of the case' cannot be
properly invoked where the case is not the same."

Fidelity & Deposit Co. of Maryland v.

Port of Seattle, (CCA 9, 1939), 106

F.2d 777, cert. den. (1940) 309 US 661

Nor where, although the case is the same, the
matter now presented was not previously determined.

Electrical Research Products v. Gross,

(CCA 9, 1941), 120 F.2d 301

Salvoni v. Pilson, (CA DC, 1950), 181 F.2d

615, cert. den. 339 US 981

1A Moore's Federal Practice, 4203-4204,

ns. 13-14

There is therefore no basis for the application
of the doctrine of the law of the case either in the
district court or this Court.

As to this Court, ". . . it is now well settled
that the 'law of the case' does not rigidly bind a
court to its former decisions but is only addressed

Label

Product

Price

Quantity

Total

Net

Gross

Profit

Loss

Gain

Share

Dividend

Interest

Income

Expense

Asset

Liability

Equity

Debt

Capital

Revenue

Cost

Value

Price

Rate

Level

Stage

to its good sense."

1A Moore's, supra, p. 4205, n. 20

Higgins v. California Prune & Apricot
Growers, (CCA 2d, 1924), 3 F.2d 896, 9

"The doctrine of the law of the case is a salutary rule of practice, but it is not a limitation on the power of the court."

United States v. Fullard-Leo, (CCA 9, 1949),
156 F.2d 756 (pt. 1)

Kemp v. United States, (CCA 8, 1947), 160
F.2d 406 (pt. 1), cert. den. (1947),
331 US 843

As to the intervenors' contentions regarding
res judicata.

It is not clear what the intervenors claim in this regard. They cannot logically claim that the issue in this appeal, i.e., the sufficiency of the "Complaint in Intervention" (which is different from the cross-complaint in 16140) could have been litigated in 16140. There was there no such pleading. Nor was there involved the issue tendered in this appeal by Hartley that the intervenors can only intervene under Judge Mathes' final order limiting the scope of intervention, under which order the intervenors elected and purported to intervene. There was such an order in 16140 and the intervenors were not even in

the State of New York,
 I, the Governor,
 do hereby certify that
 the following is a true and
 correct copy of the
 original as the same
 appears in the files of
 the Department of State,
 at Albany, New York,
 this _____ day of _____,
 19____.

 Governor

that cause. Nor was Formulabs there pleading under any order granting leave to intervene.

Not only were the issues in this appeal not involved in 16140 but they could not have been (since they occurred subsequently and were different and distinct and therefore were not and could not have been litigated and determined).

The intervenors (consistently) disregard distinctions in legal doctrines. For instance, that res judicata has two aspects: first, that of "merger" and "bar", and second, that of "collateral estoppel". The first aspect is the one that, generally, concludes issues which could have been but were not litigated. The reason is obvious, i.e., the cause of action or case is "merged" in the judgment for plaintiff or "barred" by the judgment for defendant; in either case the original cause of action is effectively extinguished.

The second aspect applies where the subsequent action is based upon a different case and cause of action. The reason is obvious, i.e., only those issues common to both actions and which were actually litigated and determined by the prior judgment are concluded, not issues which might have been but were not litigated.

Restatement, Judgments, Sec. 68, Comment d

1911

1911

1911

1911

1911

The intervenors cite (26) only Partmar Corp. et al., v. Paramount Pictures Theatres Corp., et al., (1953), 347 US 89. That case recognized the distinctions of collateral estoppel and pointed out that if a finding was not material to the first action the doctrine of collateral estoppel would not apply.

Accordingly, neither the "law of the case" nor res judicata, in either of its aspects, applies.

5-6. That the district court erred in denying the motion for preliminary injunction and in holding that "publication" of the trade secret would not "irreparably injure intervenors" (27-30).

It will be noted that the second topic was the subject of the conclusion of law to which Hartley objected but which, in any event, does not aid the intervenors.

Hereunder intervenors contend (27) that if the dismissal of their "Complaint in Intervention" was erroneous they are, in effect, automatically entitled to a preliminary injunction.

Hartley submits that this is non sequitur. A complaint may state a cause of action but a motion for preliminary injunction may not be proved and may be denied upon its merits.

They also state (27) that the only evidence in the case was to the effect that the trade secret is

worth a million dollars.

Hartley submits that this is not so. The only evidence consists of ipse dixit of Schreur's and Lacy's affidavits. These were denied by Hartley and questioned, if not denied, by du Pont which in fact denies the status of the property as a trade secret.

They further contend that the preliminary injunction would maintain the status quo pending determination of the preliminary injunction.

Hartley submits that this could only follow after the trial of the complaint between Hartley and the intervenors, regarding the controversies between them alone, which is the proper subject of the Los Angeles Superior Court action. What would du Pont be doing meanwhile?

Intervenors next (27-28) quote and discuss the license provision against disclosure.

This has been discussed in each of the causes before this Court. The license agreement patently provides against voluntary disclosure and resistance to involuntary disclosure. Hartley again submits that disclosure under a final discovery order in a suit filed by it to save its economic life arising out of its proper use of the trade secrets in litigation involving the products made by the said use of the trade secrets would not be "voluntary". To require Hartley



to dismiss the main action would be to compel it to destroy its property without the opportunity to try issues against Formulabs and the other intervenors, including that it has been and is estopped against Hartley, variously raised by Hartley in its various proceedings including its petitions for extraordinary writs.

The intervenors then state (28) that a preliminary injunction would have Hartley do what it agreed to do.

This, of course, is not so since it assumes that Hartley has no rights, that a disclosure order with proper protective measures would constitute a violation of the license agreement, that the license agreement is binding upon the court and disregards all the other arguments and contentions made by Hartley, most importantly including its basic argument that it has the right to litigate its controversy with intervenors and not have it summarily decided against it without the opportunity to be heard upon the merits. Hartley submits that the preliminary injunction would delay and destroy the main action without due process.

The intervenors then state (28) that there was no contradictory evidence to Schreur's and Lacy's affidavits which showed grounds for a preliminary injunction.

Hartley submits that this is not so. In the

first place, no grounds were shown, in the second place, the affidavits contained nothing but conclusions of law and not evidentiary facts which are required in affidavits. Further, there were oppositions by Hartley and du Pont which contained adequate grounds showing that the motion for a preliminary injunction should not be granted and the court decided the matter in accordance with said opposition thereto.

They then state (28) that the motion for a preliminary injunction was not passed upon its merits because the court did not consider the "Complaint in Intervention" acceptable.

The court determined the insufficiency of the "Complaint in Intervention". The motion for preliminary injunction depended upon it and fell with it. The court determined it had no jurisdiction of said complaint. It followed then that it had no jurisdiction of the motion for preliminary injunction. Further, there were additional grounds for denying the motion.

The intervenors then discuss (29) finding of fact 13, as to the protective provisions of the disclosure order and conclusion of law 6 that disclosure thereunder would not be a "general publication" and then they argue (29-30) that it would be a disclosure of the trade secret and quote Judge Harrison in a general comment he made which had no relevancy to any

110
111
112
113

114

115
116
117

118

119

order.

Judge Harrison's statement was a general statement. It related to no pleading or order. As a matter of fact, Judge Harrison's order contained no protective measure.

The intervenors' statement (30) that there is no recognized way to protect the trade secret during a trial particularly where a jury is demanded, is unsound. There are many cases in which disclosure of a trade secret has been made in court under appropriate discovery proceedings. The court's authority and protective measures are as effective as (if not more so than) the protective measures in the license agreement.

They then contend (30) that if they are entitled to reverse the order dismissing the complaint in intervention they are automatically entitled to a preliminary injunction.

Hartley submits again that this is non sequitur.

7. That the court erred in holding that du Pont's procedural discovery right "transcends" intervenors' ownership rights in their property (30-35).

This has been noted supra as having been an unfortunate semantic expression by du Pont, adopted by the court, to which Hartley objected but which does not aid intervenors in any event since the basic issue is

their right to intervene and the manner and scope of intervention.

Intervenors again hereunder contend that their property rights are guaranteed constitutionally.

Hartley submits its rights are also so guaranteed and they have been completely ignored so far.

They further contend (32) that intervenors owe du Pont no duty to disclose, du Pont has no right to it and Hartley is bound not to disclose.

Hartley submits that this is not a full statement of Hartley's full rights. Hartley has rights to use the trade secrets and the use thereof extends to its full use to afford Hartley all the fruits of its use including not only the products manufactured by its use of the trade secrets but in its rights to enforce all rights resulting from the sale or use of the products.

Intervenors further argue (32) that the basic concept of the court's order is that they must take the pleadings as they find them "though the requirement necessitates the waiver of or loss of property rights", that they are quite willing so to take the pleadings of the main case "but those pleadings do not raise in any issue relating to Intervenors' rights of ownership".

This shows the complete fallacy of the intervenors' position. They can take the main action as they find it or they can leave it and proceed to file

a separate and appropriate action. They would create a new basis for intervention or more properly they would force a consolidation of a state action with a federal action in the federal court. If in order to protect rights the assistance of the federal court is necessary this can be effected without destroying the doctrine of intervention and its historical definitions and applications within the court's jurisdiction. This can be done by maintaining the status quo of the federal action while the state action is tried and similar remedies.

Further, the intervenors' very statement shows that their cause of action is distinct, separate and unrelated to the main action. Unless an intervenor can and does take the issues of the main action as he finds them then he is not intervening and his entry is not intervention. The inexplicable part of the intervenors' efforts is their refusal to accept this obvious fact.

The intervenors then again discuss (32-33) Krippendorf v. Hyde, 110 US 276 and attempt to expand its holding. This has been discussed supra. The Krippendorf case did not in any way change the fundamental rules of intervention as noted supra; the proceeding involved therein was purely incidental and ancillary to the main action.



The intervenors again discuss (34) conclusion of law 5 and, among other things, state that their property rights are "decreased" because they are "compelled to intervene to assert those rights" and that 24(a)(3) does not provide for "such reduction in property rights".

If an intervenor attempts to intervene in the wrong case or attempts to improperly intervene in the right case, the adverse consequences would not be due to a defect in the procedural remedies afforded him but to his own fault in attempting to proceed improperly. The intervenors can intervene as they have been permitted to intervene by the order which has become final or they can proceed to litigate their separate cause of action in the proper forum.

Intervenors make an interesting contention (34), i.e., that conclusion of law 5 is premised on du Pont's need to defend itself yet it is not necessary that it defend itself because the district court has held that either Hartley discloses or loses; that if the intervenors succeed in stopping Hartley it will not disclose but then du Pont will prevail; that accordingly the order amounts to holding that a procedural right that du Pont does not need in order to succeed is superior to intervenors' rights to a million dollar trade secret.

of law and equity, and the
property rights, and the
period of the year, and the
20 (a) 11 12 13 14 15 16 17 18 19 20

property rights, and the
period of the year, and the
with the year, and the
rights, and the

rights, and the
period of the year, and the
with the year, and the
rights, and the

rights, and the
period of the year, and the
with the year, and the
rights, and the

rights, and the
period of the year, and the
with the year, and the
rights, and the

rights, and the
period of the year, and the
with the year, and the
rights, and the

rights, and the
period of the year, and the
with the year, and the
rights, and the

The obvious replies to this inordinate statement will not be made by Hartley, who will only state that it is assumed that Hartley has no rights at all including no right to even present its contentions and have them tried on the merits in determining the controversy between it and the intervenors.

The intervenors state (35) that if the district court had no jurisdiction it could not properly make findings of fact or conclusions of law.

Hartley, as noted supra, objected to the findings of fact and conclusions of law because they went beyond the scope of merely determining that the court had no jurisdiction and make proper conclusions to that effect.

However, this defect in the findings and the conclusions of law does not alter the fact that the court determined, upon the merits, that the "Complaint in Intervention" did not state a case within its jurisdiction and that the motion for preliminary injunction was denied upon its merits.

Conclusions (35-37).

Hereunder the intervenors make the following statements:

(1) That it was error to dismiss the said complaint for lack of jurisdiction.

This has been discussed repeatedly supra.

11/11/11

11/11/11

11/11/11

11/11/11

11/11/11

11/11/11

11/11/11

11/11/11

11/11/11

11/11/11

11/11/11

11/11/11

11/11/11

11/11/11

11/11/11

11/11/11

11/11/11

11/11/11

11/11/11

11/11/11

11/11/11

11/11/11

11/11/11

11/11/11

11/11/11

11/11/11

11/11/11

(2) That the court's orders take their property without due process of law and in violation of the federal and state constitutions, FRCP 24(a)(3) and the license agreement.

Hartley submits that this is not so at all.

Particularly is it not so as to the license agreement. Hartley has contended from the outset that the license agreement does not bind the court at all nor does it bind Hartley regarding du Pont's disclosure efforts in the main action.

(3) That the order takes intervenors' property without due process.

This is a repetition of (2).

Hartley again submits that the intervenors apparently do not understand the concept of due process; they were given access to procedure, they used it, they filed pleadings, were heard, the court also heard the opposition thereto and decided against intervenors. That is due process. Due process does not mean deciding the way intervenors want it to be decided.

(4) That the court did not follow the "law of the case".

This has been discussed supra.

(5) That the court did not accept this Court's decision in 275 F.2d 52, either as "the law

of the case" or "res judicata".

This also has been discussed supra.

(6) That if the order dismissing the said complaint is reversed intervenors should be entitled to a preliminary injunction automatically.

As noted supra, Hartley contends that this is patently non sequitur.

III

Hartley's Argument

The issues before this Court are simple.

The intervenors accepted the leave to intervene under the order signed on September 11, 1961, dated as of July 31, 1961 (on which date the oral leave was granted by Judge Mathes to the intervenors) and entered on September 21, 1961 from which the intervenors' appeal was taken in Cause 17741. That order has become and is final. It fixed the scope and limit of the intervention the intervenors can make in any action.

Their efforts to intervene inconsistently with the order are not only in contempt of it but in violation of it. Indirectly, in their proceedings before Judge Mathes, the intervenors were, in effect, attempting to change the said order. In this they failed. They are now attempting to attack the said order. It was an appealable order and reviewable by direct appeal.

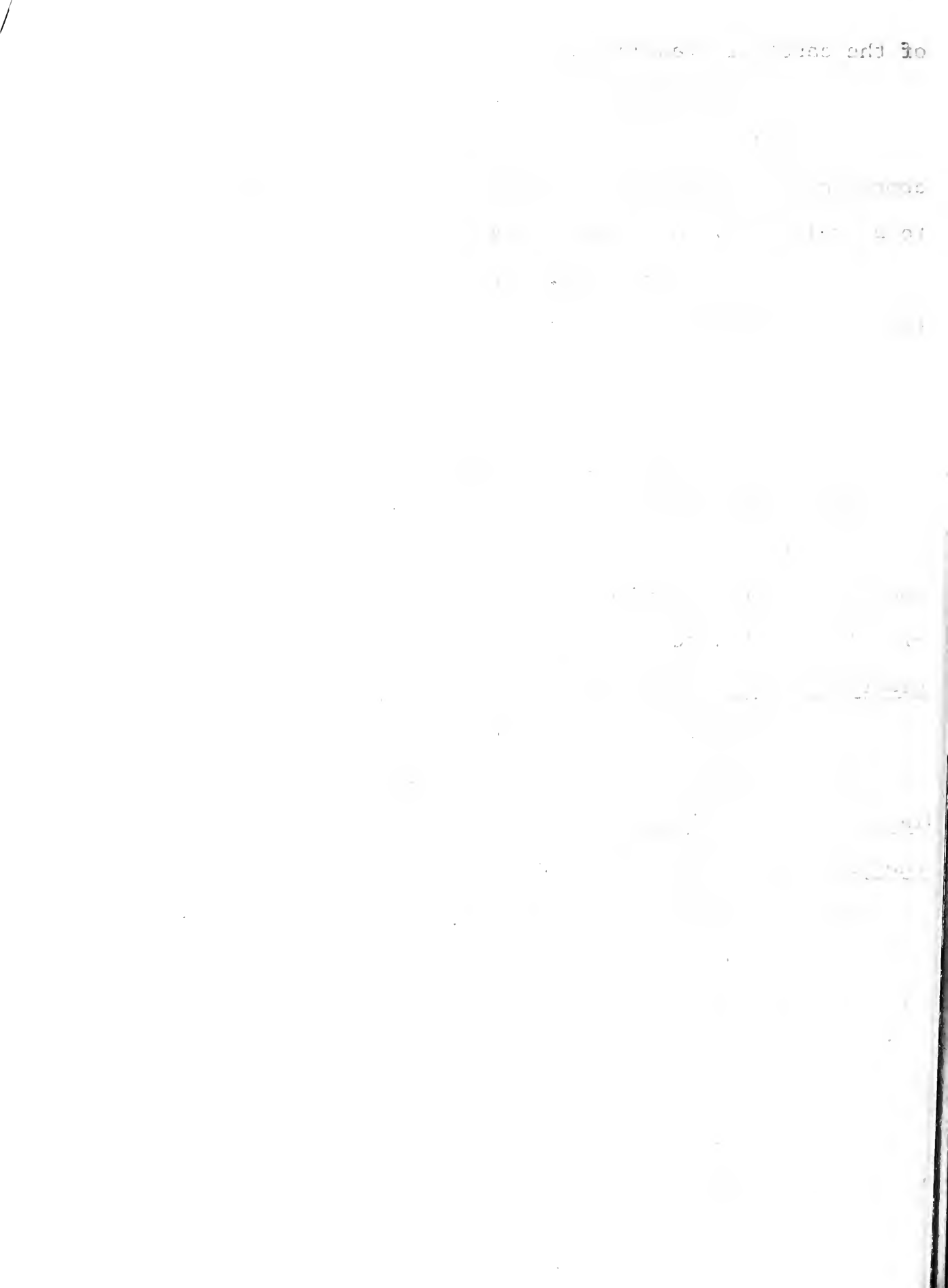

The intervenors' pending proceedings are not direct but collateral.

This has been completely overlooked so far. It is the fact that the order granting them leave to intervene has become and is final.

It is the fact that the only right the intervenors now have to intervene in the main action is under said order.

Whatever rights they may have which are not within that leave or are not connected or related to the main action must be litigated in the proper forum, i.e., the state courts.

Hartley again submits that in any event what the intervenors are attempting to do (assuming they have the right to do so and that the order is not final) is not to intervene but to consolidate or, more properly, inject a state court case into a federal case pending in the federal court. This is a hybrid proceeding and has no precedence in law.

It is elementary that where a party has two causes of action, one federal and the other non-federal, only the former is properly maintainable in the federal court. The federal jurisdiction cannot be extended by any rule of court.

Hurn v. Ousler, 289 US 238, 42

Throughout all the multiple proceedings since 1958,

The interrelationships between the various factors

but will not be discussed here.

This paper is intended to provide a general

is that the results of the study are

interesting and important.

It is hoped that this paper will

provide a basis for further research

order to determine the

of the various factors

and the results of the study

are presented in the following

sections of the paper.

The first section discusses

the objectives of the study

and the methods used.

The second section presents

the results of the study

and discusses their implications.

The third section concludes

the paper and suggests

directions for future research.

The fourth section discusses

the limitations of the study

and the conclusions drawn.

The fifth section discusses

the significance of the study

when Formulabs began its efforts to intervene, to date, it has been completely overlooked that Hartley has substantial rights, at least the equivalent of, if not superior (as Hartley contends) to the intervenors' rights to the trade secrets.

Hartley has the right to maintain the main action and should not be compelled to dismiss it.

Hartley has variously contended from the very outset that disclosure under a proper final disclosure order, with appropriate protective measures, will not constitute "publication" or a destruction of the trade secret; that the license agreement does not bind the court nor does it bind Hartley, if Hartley has (and it has) exercised all due care in resisting involuntary disclosure and in requiring the court to make it a proper and final order of disclosure; that it was in the contemplation of Hartley and the intervenors that Hartley would use the trade secret in manufacturing its product and would sell its product and that in the sale of its product public liability would arise either defensively, requiring Hartley to defend itself against product liability actions, or affirmatively, by Hartley's filing actions arising out of its manufacture and sale of its products, such litigation was inherent in Hartley's business and the use of the trade secrets in such litigation was probable.

when formula 2 is applied to the data in table 1
it has been suggested that the following formula
substituted for the one in formula 1
suggested by the author of the paper
table 1
and 2
part 1
part 2
part 3
part 4
part 5
part 6
part 7
part 8
part 9
part 10
part 11
part 12
part 13
part 14
part 15
part 16
part 17
part 18
part 19
part 20
part 21
part 22
part 23
part 24
part 25
part 26
part 27
part 28
part 29
part 30
part 31
part 32
part 33
part 34
part 35
part 36
part 37
part 38
part 39
part 40
part 41
part 42
part 43
part 44
part 45
part 46
part 47
part 48
part 49
part 50
part 51
part 52
part 53
part 54
part 55
part 56
part 57
part 58
part 59
part 60
part 61
part 62
part 63
part 64
part 65
part 66
part 67
part 68
part 69
part 70
part 71
part 72
part 73
part 74
part 75
part 76
part 77
part 78
part 79
part 80
part 81
part 82
part 83
part 84
part 85
part 86
part 87
part 88
part 89
part 90
part 91
part 92
part 93
part 94
part 95
part 96
part 97
part 98
part 99
part 100

Hartley should have the right to litigate its substantial property rights in the trade secrets. It established the trade secrets commercially and has paid substantial royalties. Nevertheless, the intervenors have licensed the secrets to others in competition with Hartley as well as used the secrets themselves in competition to Hartley.

Among the absurd statements the intervenors make is that trade secrets could not be protected by the protective orders under the discovery proceedings. The very statement illustrates its fallacy. Trade secrets are discoverable and they are protectable properly by protective measures in discovery orders. The applicable rules so provide.

The intervenors ignore every basic concept of intervention. Hartley repeats that intervention obviously means that a party enters into the main action within the issues framed therein between the parties to it, which issues are to be determined upon their merits by a final judgment. It does not mean that they can inject into the federal main action an entirely different cause of action, separate and apart and otherwise cognizable only in a state court under the guise of protecting their property rights in discovery proceedings.

This Court did not nor could it have decided in

substantive part of the...
established...
part...
...

...

...

...

...

...

...

275 F.2d 52 that intervention can be made by injecting the state case into the federal case in the federal court under the guise of a tenuous right in discovery proceedings. It did decide that the intervenors can intervene in resisting du Pont's efforts to obtain disclosure of the trade secrets.

In all the intervenors' tactical maneuvering the fact remains that they find themselves bound by the order granting leave to intervene in a specified and limited way. They can not expand it now.

Hartley submits that the practical matter would be to have their declaratory relief action in Los Angeles Superior Court determined and thereby decide the controversy between Hartley and the intervenors.

The unfortunate development is that the intervenors have been permitted to inject the completely non-federal case between themselves and Hartley into the main action between Hartley and du Pont and that Hartley has been placed in the position of having been deprived of all right to litigate that separate controversy between it and the intervenors and threatened with a destruction of its main action. There is no precedence for this. The extended research by Hartley's counsel has not disclosed a comparable situation.

The first issue is whether the court should grant summary judgment. The court notes that the plaintiff has presented sufficient evidence to raise a genuine issue of material fact. Therefore, summary judgment is denied.

The second issue is whether the defendant is entitled to judgment as a matter of law. The court finds that the defendant's motion for summary judgment is also denied because the plaintiff has shown that the defendant's conduct was negligent.

The court then addresses the issue of damages. The plaintiff seeks compensation for the loss of the property. The court determines that the plaintiff is entitled to the fair market value of the property at the time of the loss.

Finally, the court considers the issue of attorney's fees. The court holds that the plaintiff is entitled to reasonable attorney's fees because the defendant's conduct was willful and wanton.

The court concludes by affirming the judgment of the lower court and awarding the plaintiff the full amount of damages and attorney's fees.

Conclusion

It is respectfully submitted that the order was proper, that the intervenors' attempts to intervene are not intervention at all but efforts to develop a new ground of federal jurisdiction and to thereby consolidate or inject a state case into a federal case pending in a federal court under the guise of discovery proceedings, utilizing for that purpose this Court's decision in 275 F.2d 52.

Hartley submits that its petition for extraordinary writs shows that du Pont is not entitled to disclosure. This will dispose of all matters. In any event, assuming that du Pont continues and can continue its attempts to show, and can show, good cause for disclosure, Hartley is entitled to litigate its controversy with the intervenors once and for all in the state case.

Hartley respectfully submits that this appeal should be denied and the orders affirmed.

OWEN A. BARTLETT and
A.V. FALCONE

By: A.V. FALCONE

Attorneys for Appellee
Hartley Pen Company

is a...
properly...
side not...
particular...
collected...
pending...
procedures...
decisions...
action...
management...
evidence...
event...
let...
dim...
w...
the...
...
...

No. 18180

IN THE UNITED STATES COURT OF APPEALS
FOR THE NINTH CIRCUIT

FORMULABS, INCORPORATED, a corporation,
CLARENCE SCHREUR and GORDON S. LACY,
individuals doing business as PACIFIC
RESEARCH LABORATORY, a co-partnership,

Appellants,

vs.

HARTLEY PEN COMPANY, a corporation,
doing business as THE HARTLEY CO., and
E. I. du PONT de NEMOURS & COMPANY,
a corporation,

Appellees.

INTERVENORS' BRIEF IN REPLY TO
APPELLEE HARTLEY PEN CO.'S
ANSWERING BRIEF

WILLIAM DOUGLAS SELLERS
16 North Marengo Avenue
Pasadena, California

Attorney for Appellants, Formulabs,
Incorporated, Clarence Schreur and
Gordon S. Lacy, dba Pacific
Research Laboratory

FILED

JAN 28 1963

FRANK H. SCHMIDT, CLERK

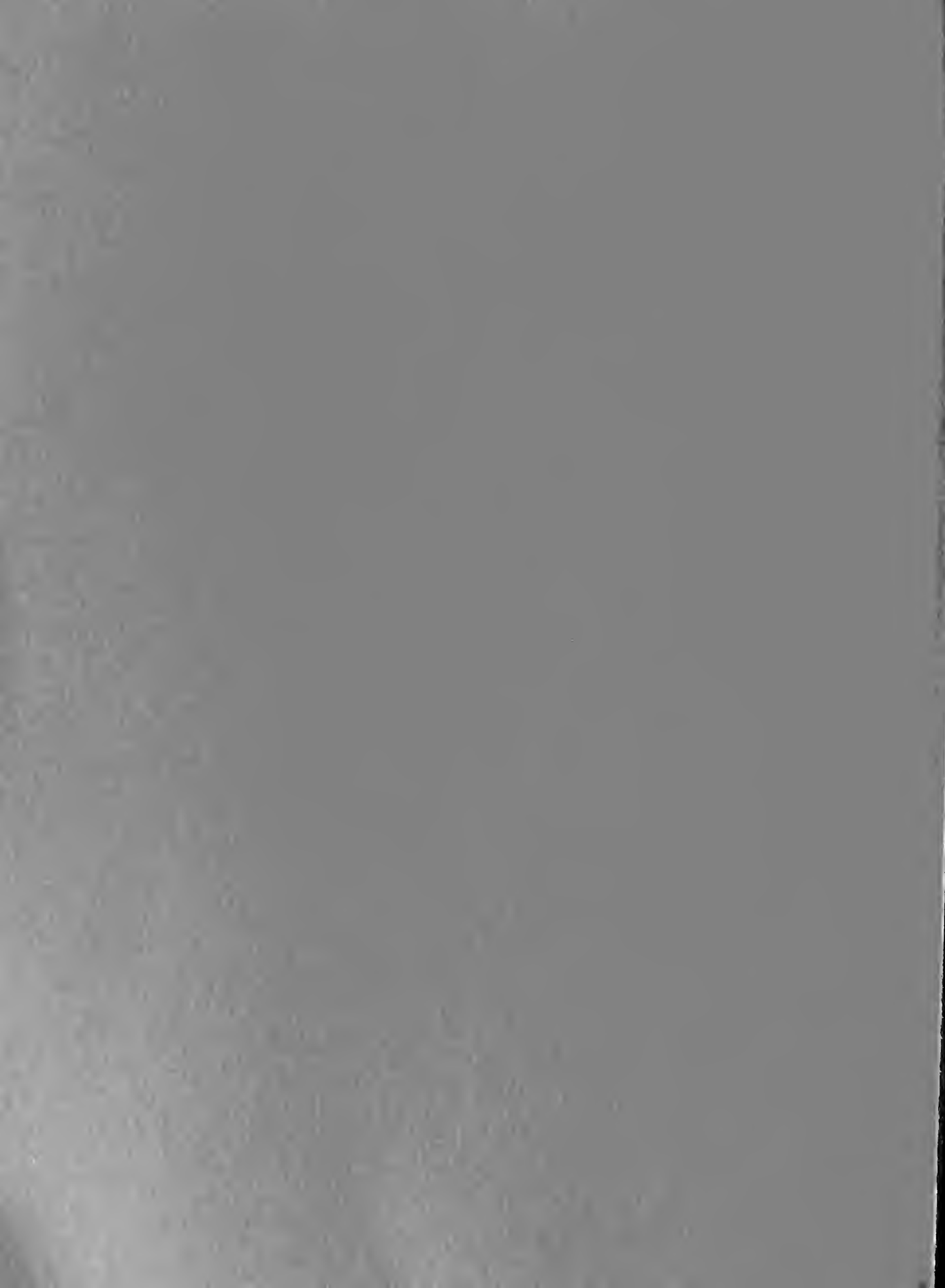

No. 18180

IN THE UNITED STATES COURT OF APPEALS
FOR THE NINTH CIRCUIT

FORMULABS, INCORPORATED, a corporation,
CLARENCE SCHREUR and GORDON S. LACY,
individuals doing business as PACIFIC
RESEARCH LABORATORY, a co-partnership,

Appellants,

vs.

HARTLEY PEN COMPANY, a corporation,
doing business as THE HARTLEY CO., and
E. I. du PONT de NEMOURS & COMPANY,
a corporation,

Appellees.

INTERVENORS' BRIEF IN REPLY TO
APPELLEE HARTLEY PEN CO.'S
ANSWERING BRIEF

WILLIAM DOUGLAS SELLERS
16 North Marengo Avenue
Pasadena, California

Attorney for Appellants, Formulabs,
Incorporated, Clarence Schreur and
Gordon S. Lacy, dba Pacific
Research Laboratory

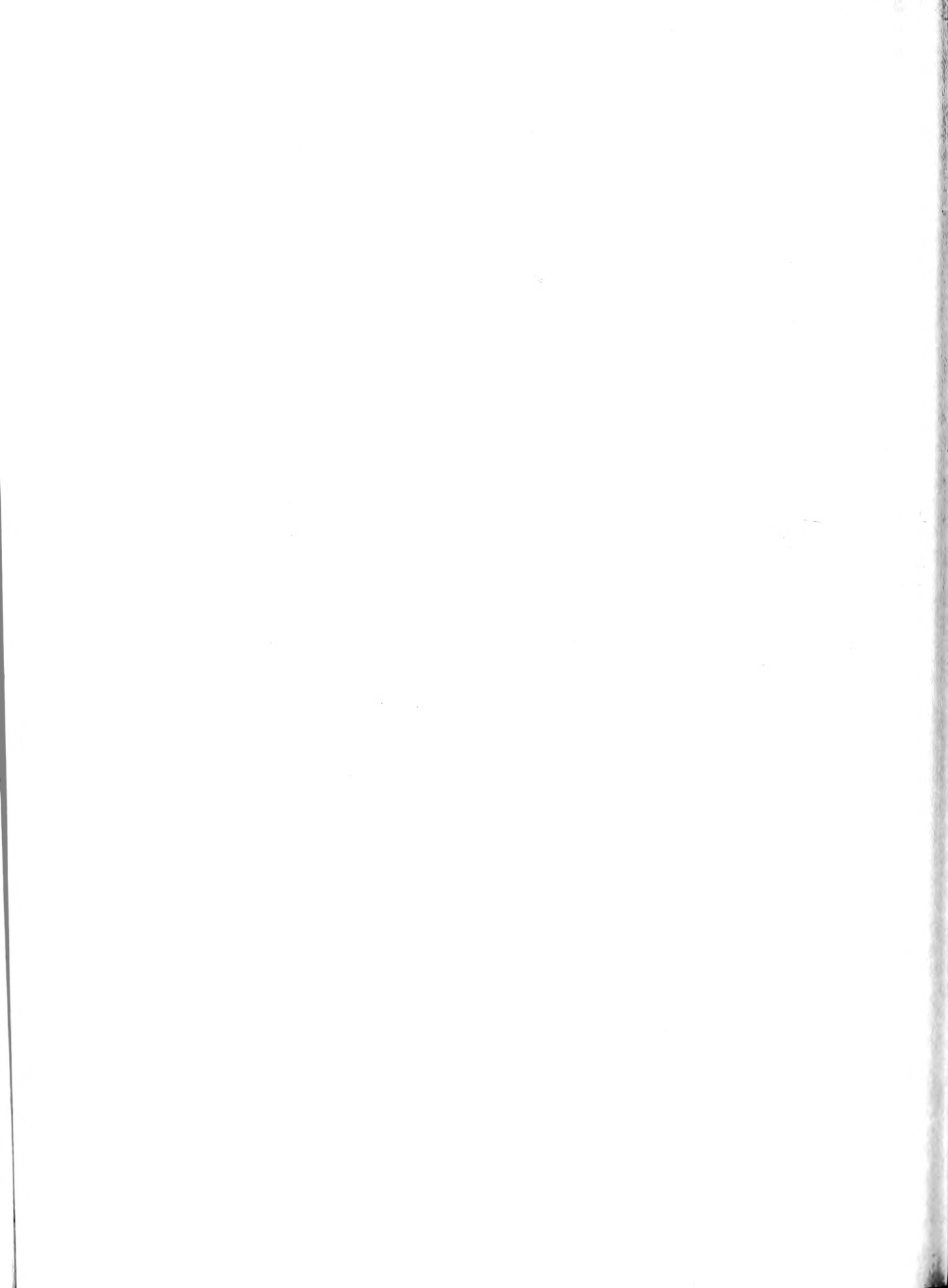

TOPICAL INDEX

| | <u>Page</u> |
|--|-------------|
| PREFACE | 1 |
| SUMMARY OF ARGUMENT | 2 |
| ARGUMENT | 6 |
| I. HARTLEY IN ERROR CONTENDS THE DISTRICT COURT ORDER (App. pp. 122-124) DATED JULY 31, 1961, SIGNED SEPTEMBER 11, 1961, AND FILED SEPTEMBER 21, 1961, BARS INTERVENORS FROM FILING THEIR PRESENT COMPLAINT IN INTERVENTION (App. pp. 58-65) FILED AUGUST 9, 1961, AND ACTED UPON AND DISMISSED BY THE DISTRICT COURT ON JULY 30, 1962 (Tr. pp. 61-64), FROM WHICH DISMISSAL THIS APPEAL WAS TAKEN ON AUGUST 10, 1962 (Tr. pp. 78-80). | 6 |
| II. HARTLEY IN ERROR MAKES THE CONTENTION AT SCATTERED POINTS THROUGHOUT ITS BRIEF THAT ITS PROPERTY RIGHTS AND ITS CONSTITUTIONAL RIGHTS ARE BEING IGNORED. | 10 |
| III. HARTLEY CONTENDS: "IN HARTLEY'S OPPOSITION TO THE INTERVENORS' CONTENTIONS ON SAID APPEAL (16140) IT, AMONG OTHER THINGS, CONTENDED THAT THE CROSS-COMPLAINT WAS INSUFFICIENT AS A PLEADING AND DID NOT SATISFY FRCP 24(c). THIS COURT DID NOT RULE ON THIS." (Parenthetical matter added.) (Hartley Brief, p. 16). | 13 |
| IV. HARTLEY CONTENDS: NOTWITHSTANDING THE EXPRESS PROVISIONS OF ITS LICENSE AGREEMENT PROHIBITING DISCLOSURE OF THE TRADE SECRET IT HAS THE RIGHT TO DISCLOSE AND THIS "WAS PATENTLY ANTICIPATED BY HARTLEY AND THE INTERVENORS". (Hartley Reply Brief, p. 24). | 16 |



V. HARTLEY CONTENDS:

"HARTLEY COULD HAVE LONG AGO DISCLOSED IN THE MAIN ACTION (PRIOR TO THIS COURT'S INJUNCTION AGAINST IT ON FEBRUARY 2, 1962) WITH NO OTHER CONSEQUENCE THAN FORMULABS' SUIT, IF ANY, TO CLAIM DAMAGES THEREFOR."
(Hartley Brief, p. 33).

17

VI. HARTLEY CONTENDS:

THIS COURT AUTHORIZED INTERVENTION IN APPEAL 16140 " . . . BUT HOW OR BY WHAT PLEADING IT DID NOT DECIDE. THERE WAS NO PLEADING ISSUE BEFORE THIS COURT AND THIS COURT DID NOT DETERMINE ANY PLEADING ISSUE."
(Hartley Brief, p. 37).

18

VII. HARTLEY CONTENDS:

"AS TO THE INTERVENORS' REPEATED CONTENTIONS THAT THEY WERE DENIED DUE PROCESS BECAUSE THE COURT DISMISSED THEIR COMPLAINT IN INTERVENTION AND DENIED THE MOTION FOR PRELIMINARY INJUNCTION, HARTLEY SUBMITS THAT THEIR CONTENTIONS ARE PATENTLY WITHOUT ANY MERIT AT ALL."
(Hartley Brief, p. 42).

21

VIII. HARTLEY CONTENDS:

"THE INTERVENORS STATE (14) 'THE OWNERSHIP RIGHTS OF INTERVENORS ARE UNCONTESTED.'

"HARTLEY STATES THAT THIS IS NOT SO. HARTLEY HAS SERIOUSLY QUESTIONED THIS . . ." (Hartley Brief, p. 45).

22

IX. HARTLEY CONTENDS:

"THE INTERVENORS CONFUSEDLY ARGUE (17-20) THAT NO DIVERSITY IS REQUIRED TO INTERVENE UNDER FRCP 24(a)(3) AND THAT THIS WAS ESTABLISHED BY THIS COURT IN 275 F.2d 52. (Continued)

23

| | <u>Page</u> |
|--|-------------|
| IX. (Continued) "HARTLEY ADMITS THAT NO DIVERSITY IS REQUIRED TO INTERVENE UNDER 24(a)(3) UNDER PROPER CIRCUMSTANCES AND UPON A <u>PROPER RECORD</u> ." (Emphasis added) (Hartley Brief, p. 48). | 23 |
| X. HARTLEY CONTENDS: RELATIVE TO INTERVENORS' STATEMENT ON PAGE 26 OF THEIR BRIEF THAT "NO OBJECTION WAS MADE BY ANY PARTY TO THAT FIRST APPEAL THAT THE COMPLAINT IN INTERVENTION WAS IMPROPERLY DIRECTED AGAINST HARTLEY ALONE", THAT: "THIS IS A COMPLETELY INCORRECT STATEMENT OF THE RECORD. HARTLEY NOT ONLY OBJECTED BUT EMPHASIZED THE ABSURDITY OF THE CONTENTION THAT JUDGE HARRISON COULD ORDER DISCLOSURE (FORMULABS SO STATED) AND COULD THEN, AT FORMULABS' REQUEST, ORDER HARTLEY NOT TO OBEY HIS OWN ORDER TO DISCLOSE!" (Hartley Brief, p. 55). | 24 |
| XI. HARTLEY CONTENDS: "THE PLEADING IN THIS APPEAL, I. E. , INTERVENORS' 'COMPLAINT IN INTERVENTION', IS DIFFERENT FROM FORMULABS' CROSS-COMPLAINT IN 16140." (Hartley Brief, pp. 57, 58). | 27 |
| XII. HARTLEY'S ARGUMENT (Hartley Brief, pp. 71-75). | 28 |
| CONCLUSION | 29 |



TABLE OF AUTHORITIES

| <u>Cases</u> | <u>Page</u> |
|---|-----------------------|
| Formulabs v. Hartley, 275 F.2d 52, 124 USPQ 398 | 11, 23 |
| Hurn v. Ousler, 289 U.S. 238, 77 L.Ed. 1148, 53 S.Ct. 586 | 29 |
| Partmar Corp. v. Paramount Pictures Theatres Corp. et al. (S.Ct. 1953), 347 U.S. 89, 74 S.Ct. 414 | 25 |
| <u>Rules</u> | |
| Federal Rules of Civil Procedure: | |
| Rule 24(a)(3) | 23, 29 |
| Rule 24(c) | 7, 13, 14, 15, 18, 23 |
| <u>Texts</u> | |
| 2 Barron & Holtzoff, Federal Practice and Procedure, §603, p. 233, n. 99 | 14 |
| 4 Moore's Federal Practice, §24.14, p. 101, n. 1 | 14 |

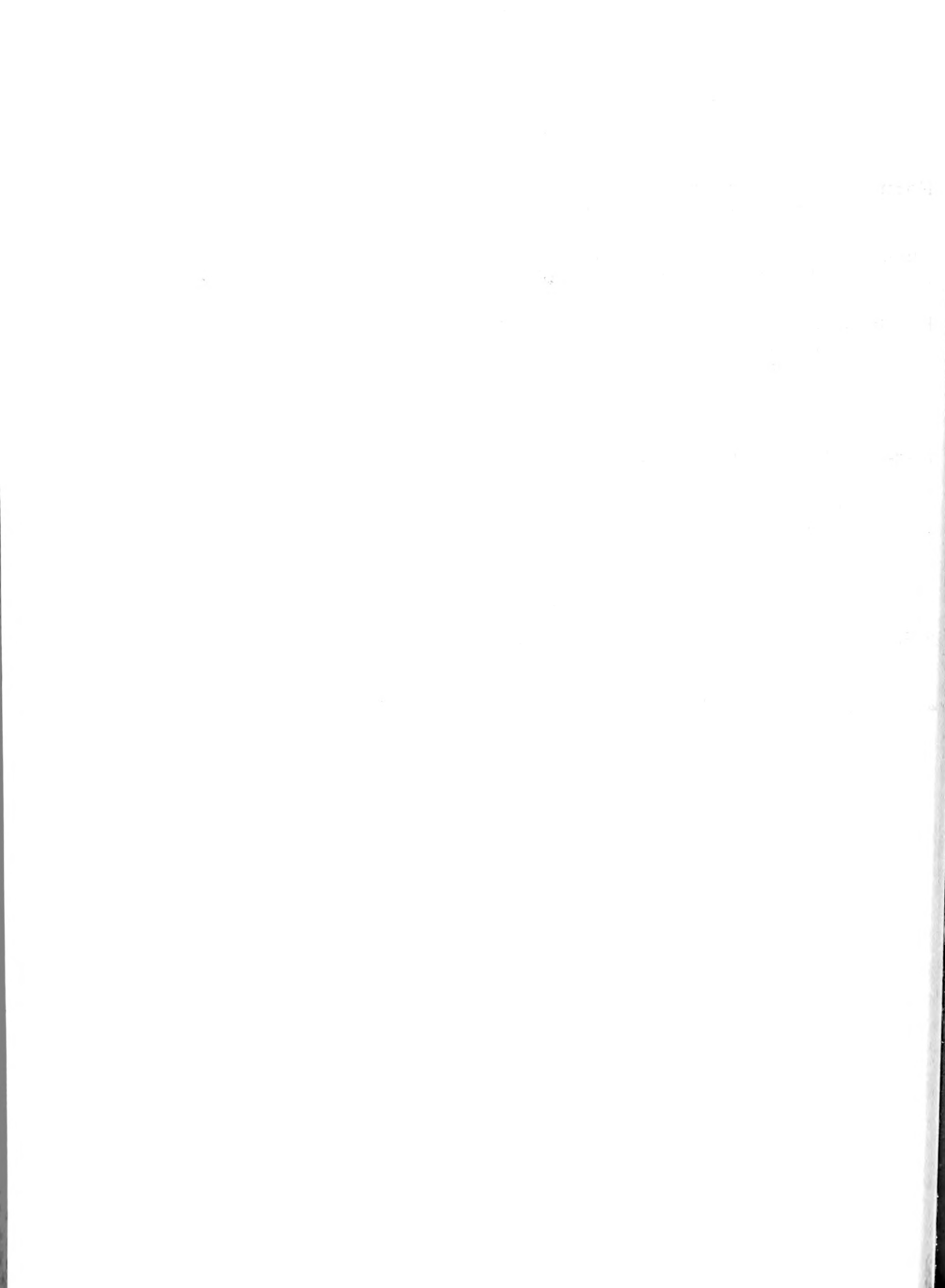

No. 18180

IN THE UNITED STATES COURT OF APPEALS
FOR THE NINTH CIRCUIT

FORMULABS, INCORPORATED, a corporation,
CLARENCE SCHREUR and GORDON S. LACY,
individuals doing business as PACIFIC
RESEARCH LABORATORY, a co-partnership,

Appellants,

vs.

HARTLEY PEN COMPANY, a corporation,
doing business as THE HARTLEY CO., and
E. I. du PONT de NEMOURS & COMPANY,
a corporation,

Appellees.

INTERVENORS' BRIEF IN REPLY TO
APPELLEE HARTLEY PEN CO.'S
ANSWERING BRIEF

PREFACE

This is Intervenor's reply to Hartley's answering brief of
76 pages.

Herein, as in prior briefs, the appellee Hartley Pen
Company will be referred to as Hartley, and the appellee E. I.
du Pont de Nemours & Company as du Pont.

The record designation is set forth on page 3 of Intervenor's
opening brief.



SUMMARY OF ARGUMENT

I

HARTLEY IN ERROR CONTENDS THE DISTRICT COURT ORDER (App. pp. 122-124) DATED JULY 31, 1961, SIGNED SEPTEMBER 11, 1961, AND FILED SEPTEMBER 21, 1961, BARS INTERVENORS FROM FILING THEIR PRESENT COMPLAINT IN INTERVENTION (App. pp. 58-65) FILED AUGUST 9, 1961, AND ACTED UPON AND DISMISSED BY THE DISTRICT COURT ON JULY 30, 1962 (Tr. pp. 61-64), FROM WHICH DISMISSAL THIS APPEAL WAS TAKEN ON AUGUST 10, 1962 (Tr. pp. 78-80).

II

HARTLEY IN ERROR MAKES THE CONTENTION AT SCATTERED POINTS THROUGHOUT ITS BRIEF THAT ITS PROPERTY RIGHTS AND ITS CONSTITUTIONAL RIGHTS ARE BEING IGNORED.

III

HARTLEY CONTENDS:

"IN HARTLEY'S OPPOSITION TO THE INTERVENORS' CONTENTIONS ON SAID APPEAL (16140) IT, AMONG OTHER THINGS, CONTENTED THAT THE CROSS-COMPLAINT WAS INSUFFICIENT AS A PLEADING AND DID NOT SATISFY FRCP 24(c). THIS COURT DID NOT RULE ON THIS."



IV

HARTLEY CONTENDS:

NOTWITHSTANDING THE EXPRESS PROVISIONS OF ITS LICENSE AGREEMENT PROHIBITING DISCLOSURE OF THE TRADE SECRET IT HAS THE RIGHT TO DISCLOSE AND THIS "WAS PATENTLY ANTICIPATED BY HARTLEY AND THE INTERVENORS".

V

HARTLEY CONTENDS:

"HARTLEY COULD HAVE LONG AGO DISCLOSED IN THE MAIN ACTION (PRIOR TO THIS COURT'S INJUNCTION AGAINST IT ON FEBRUARY 2, 1962) WITH NO OTHER CONSEQUENCE THAN FORMULABS' SUIT, IF ANY, TO CLAIM DAMAGES THEREFOR."

VI

HARTLEY CONTENDS:

THIS COURT AUTHORIZED INTERVENTION IN APPEAL 16140 " . . . BUT HOW OR BY WHAT PLEADING IT DID NOT DECIDE. THERE WAS NO PLEADING ISSUE BEFORE THIS COURT AND THIS COURT DID NOT DETERMINE ANY PLEADING ISSUE. "

VII

HARTLEY CONTENDS:

"AS TO THE INTERVENORS' REPEATED CONTENTIONS THAT THEY WERE DENIED DUE PROCESS

2

3

4

5

6

7

8

9

10

BECAUSE THE COURT DISMISSED THEIR COMPLAINT IN INTERVENTION AND DENIED THE MOTION FOR PRELIMINARY INJUNCTION, HARTLEY SUBMITS THAT THEIR CONTENTIONS ARE PATENTLY WITHOUT ANY MERIT AT ALL. "

VIII

HARTLEY CONTENDS:

"THE INTERVENORS STATE (14) 'THE OWNERSHIP RIGHTS OF INTERVENORS ARE UNCONTESTED. '

"HARTLEY STATES THAT THIS IS NOT SO. HARTLEY HAS SERIOUSLY QUESTIONED THIS, . . . "

IX

HARTLEY CONTENDS:

"THE INTERVENORS CONFUSEDLY ARGUE (17-20) THAT NO DIVERSITY IS REQUIRED TO INTERVENE UNDER FRCP 24(a)(3) AND THAT THIS WAS ESTABLISHED BY THIS COURT IN 275 F. 2d 52.

"HARTLEY ADMITS THAT NO DIVERSITY IS REQUIRED TO INTERVENE UNDER 24(a)(3) UNDER PROPER CIRCUMSTANCES AND UPON A PROPER RECORD. "

X

HARTLEY CONTENDS:

RELATIVE TO INTERVENORS' STATEMENT ON PAGE 26 OF THEIR BRIEF THAT "NO OBJECTION WAS MADE BY ANY PARTY TO THAT FIRST APPEAL THAT THE COMPLAINT



IN INTERVENTION WAS IMPROPERLY DIRECTED AGAINST HARTLEY ALONE", THAT:

"THIS IS A COMPLETELY INCORRECT STATEMENT OF THE RECORD. HARTLEY NOT ONLY OBJECTED BUT EMPHASIZED THE ABSURDITY OF THE CONTENTION THAT JUDGE HARRISON COULD ORDER DISCLOSURE (FORMULABS SO STATED) AND COULD THEN, AT FORMULABS' REQUEST, ORDER HARTLEY NOT TO OBEY HIS OWN ORDER TO DISCLOSE!"

XI

HARTLEY CONTENDS:

"THE PLEADING IN THIS APPEAL, i. e. , INTERVENTORS' 'COMPLAINT IN INTERVENTION', IS DIFFERENT FROM FORMULABS' CROSS-COMPLAINT IN 16140. "

XII

HARTLEY'S ARGUMENT (HARTLEY BRIEF, pp. 71-75).

CONCLUSIONS



ARGUMENT

Hartley makes a few contentions justifying detailed discussion, and a large number of contentions justifying corrective comment.

The first Hartley contention viewed as needing detailed discussion is as follows:

I.

HARTLEY IN ERROR CONTENDS THE DISTRICT COURT ORDER (App. pp. 122-124) DATED JULY 31, 1961, SIGNED SEPTEMBER 11, 1961, AND FILED SEPTEMBER 21, 1961, BARS INTERVENORS FROM FILING THEIR PRESENT COMPLAINT IN INTERVENTION (App. pp. 58-65) FILED AUGUST 9, 1961, AND ACTED UPON AND DISMISSED BY THE DISTRICT COURT ON JULY 30, 1962 (Tr. pp. 61-64), FROM WHICH DISMISSAL THIS APPEAL WAS TAKEN ON AUGUST 10, 1962 (Tr. pp. 78-80).

This Hartley contention is found scattered through its brief at p. 11, p. 13 (2nd par.), p. 15 (2nd par.), p. 45 (5th par.), p. 49 (4th par.), p. 57 (2nd par.), p. 59 (last par.), p. 71 (6th par.) and p. 72 (4th par.).

Briefly, it is the Hartley contention that Intervenors were barred from filing their "Complaint in Intervention" (App. pp. 58-65), filed August 9, 1961, because it was not consistent with the District Court's Order filed September 21, 1961, signed September 11, 1961, backdated to July 31, 1961.

The Hartley contention is confused and without merit.

The relevant facts are set forth by Intervenors at App. p. 9,



par. 14 - p. 14, par. 30.

FIRST. The District Court's Order was modified, settled and signed September 11, 1961, and filed September 21, 1961. The present Complaint in Intervention was filed August 9, 1961, nearly six weeks earlier.

SECOND. The District Court Order dismissed, with right to amend, the first count of the earlier complaint of Formulabs (First Amended Pleading of Intervenor, App. pp. 102-113) which was substantially identical to the complaint before this Court in Appeal No. 16140, and dismissed without leave to amend two additional counts seeking declaratory relief; it granted permission to Schreur and Lacy to intervene joining Formulabs on the first count, but denied them the right to file their proposed "Intervenors' Cross-Complaint for Declaratory Judgment and for Injunction" (App. pp. 81-89), containing two counts substantially identical to the two counts of the Formulabs' complaint which were dismissed without leave to amend.

THIRD. The present Complaint in Intervention, basically similar to the first count of the Formulabs' complaint which Formulabs was given the right to amend, seeks the same relief as did the original proposed complaint before this Court in Appeal No. 16140 (present by virtue of the requirement of FRCP 24(c)), in which appeal this Court granted the right to intervene.

FOURTH. The present "Complaint in Intervention of Formulabs, Incorporated, Clarence Schreur and Gordon S. Lacy" was filed August 9, 1961, and was dismissed by the District Court

Order of July 31, 1962 (Tr. pp. 61-64) and supplemental orders which made that order final, as set forth in Intervenors' opening brief at page 4.

FIFTH. It is from that final order and judgment directed to the present complaint that this appeal is taken. If, in the view of the District Court, Intervenors were barred from filing the present complaint by virtue of an order the present complaint should have been dismissed upon that ground. It was not.

SIXTH. The reasons for the failure of the District Court to dismiss the present Complaint in Intervention as being barred by the Order of September 21, 1961 (not July 31, 1961) are clear. They are: (a) the present complaint was filed before the order was made, (b) the complaint was filed after the hearing on July 31, 1961 (App. pp. 159-169) at which the District Court, in addition to other things it said denying the right, gave oral permission to file that complaint and in the following words:

"MR. SELLERS: If I may understand clearly, your Honor, your Honor's position is that I have no right to assert absolutely my ownership rights or my client's ownership rights against Hartley to prevent the disclosure by Hartley --

"THE COURT: You assert every claim you can make in that first count, if you want to.

"MR. SELLERS: I didn't finish, your Honor, I am sorry.

"THE COURT: You can assert all the contracts



you want and all the rights you want. "

(App. p. 165).

SEVENTH: To the extent the present complaint is, in the view of the District Court, improper, that was a grounds of dismissal of the present complaint. It is from the dismissal of the present complaint the present appeal is taken.



II

HARTLEY IN ERROR MAKES THE CONTENTION AT SCATTERED POINTS THROUGHOUT ITS BRIEF THAT ITS PROPERTY RIGHTS AND ITS CONSTITUTIONAL RIGHTS ARE BEING IGNORED

Hartley makes this contention at p. 25, par. 2; p. 27, 1st par.; p. 31, 1st par.; p. 32; p. 33; p. 34, third par.; p. 47, 3rd par.; p. 49, 2nd par.; p. 52, last par.; p. 66, 3rd par.; p. 69, 1st par.; and p. 73, 1st par.

Hartley is the appellee here. It has prevailed below. But Hartley is still complaining.

Hartley has made diametrically opposite representation as to its rights in and obligations relative to the trade secret to the extent that both Intervenors and du Pont are confused.

At each of the places in its answering brief identified above Hartley refers to the property rights it has in Intervenors' trade secret which, at an earlier, clearer day, it recognized as belonging to Intervenors.

Du Pont's understandable confusion resulting from the vacillating Hartley position is evident in its answering Brief when it says:

"In the present case, by contrast, neither Hartley nor du Pont disputes Intervenors' claimed proprietary rights or asserts any paramount interest (or in the case of du Pont, any interest at all) in the secret ballpen in formulae."



This Court was clearly of the opinion that Hartley did not claim ownership when it said:

"The use of the secret formula by Hartley was under the terms of a written license agreement between Hartley and Formulabs.

"In our view, Formulabs is so situated. Admittedly it is the owner of the secret formula and the secret testing procedures."

(Formulabs v. Hartley, 275 F.2d 52,
124 USPQ 398)

Hartley formerly freely admitted it did not have ownership rights, or the right to disclose, and said to Judge Harrison:

"MR. FALCONE: If you make such an order, your Honor, as we told you in conference in chambers, we will accede to it, but we are going contrary to our contract with our licensor."

(Appeal 16140, Tr. p. 272)

Compare that statement with the statements now made by Hartley:

"Formulabs is not in the position of an owner opposing a stranger to its title or property. Hartley has rights and stands on parity, if not greater, rights with Formulabs."

(Hartley Brief, p. 26)

"The fact remains that Hartley has constantly



contended, and does, that it has co-extensive if not superior rights to the intervenors in the trade secrets. "

(Hartley Brief, p. 47)

Hartley, having made an about turn, now contends it has property rights in Intervenor's secret; contends that despite the express wording of the contract denying Hartley the right to disclose (App. p. 64, par. 2) it has an implied right to disclose; contends again and again that its property rights are being ignored.

Hartley's argument is supported only by its own opinion inconsistent with its own earlier views. It cites no law to support its unusual contention of ownership rights. It appreciates, of course, that any contention of ownership rights contrary to Intervenor's, however unrealistic, buttresses the District Court's refusal to take the case upon the grounds it will not decide contested rights between Intervenor and Hartley.

The simple facts are:

1. The continued existence of a binding contract between Intervenor and Hartley is admitted.
2. That contract clearly on its face binds Hartley not to disclose.
3. Hartley contends upon an unsupported legal theory that despite (2) it has the right to disclose.

No right of Hartley is being ignored. How could it be?

The need to assert Hartley's rights in the property could arise only if Intervenor were first given the opportunity to assert

their rights. To date this opportunity has been denied them. The Hartley position is confused, unrealistic, contrary to logic and unsupported by a single citation in point.

III

HARTLEY CONTENDS:

"IN HARTLEY'S OPPOSITION TO THE INTERVENORS' CONTENTIONS ON SAID APPEAL (16140) IT, AMONG OTHER THINGS, CONTENDED THAT THE CROSS-COMPLAINT WAS INSUFFICIENT AS A PLEADING AND DID NOT SATISFY FRCP 24(c). THIS COURT DID NOT RULE ON THIS." (Parenthetical matter added.)

(Hartley Brief, p. 16)

Intervenors in their opening Brief, in combined titles 3 and 4 at pages 25, 26, state the "issue of the right of Formulabs to intervene with a proposed complaint seeking the exact relief sought by the complaint now dismissed by the District Court was decided in this Court" in Appeal No. 16140.

FRCP 24(c) provides:

"A person desiring to intervene shall serve a motion to intervene upon all parties affected thereby. The motion shall state the grounds therefor, and shall be accompanied by a pleading setting forth the claim or defense for which intervention is sought . . ."

The right to intervene was dependent upon the presence of a pleading asserting a good claim.



2 Barron & Holtzoff, Federal Practice and Procedure, §603, p. 233, n. 99;

4 Moore's Federal Practice, §24.14, p. 101, n. 1.

This Court was aware of the claim made by the proposed Complaint in Intervention in Appeal No. 16140 and said with respect thereto:

" . . . The cross complaint prayed that Hartley be enjoined from disclosing such trade secrets. "

(275 F.2d 52, 54)

Hartley asserts (Hartley Brief, p. 16, p. 43, p. 55) that it contended in Appeal 16140, in its petition for rehearing, and in its petition for certiorari, that the complaint "was insufficient". It did.

Accordingly, the controlling facts are as follows:

1. The presence of a proposed pleading was a prerequisite for intervention under FRCP 24(c).
2. A proposed pleading seeking the same relief as the presently dismissed complaint was then before this Court.
3. This Court understood the relief sought.
4. Hartley contended the complaint "was insufficient".
5. This Court held the intervenor had the right to intervene.

Hartley now seeks to have this Court rule in effect that when it held in Appeal 16140 that the intervenor could intervene this Court really meant:



1. That intervention of some kind was proper but not intervention seeking the relief sought by the only pleading before the Court;
2. That the intervenor, contrary to the decision, did not really have the right to intervene seeking the relief the Court knew it was seeking and which relief it discussed in its decision;
3. That despite the fact Hartley contended before this Court the Intervenor's pleading "was insufficient" this Court did not consider that question when it held intervention was proper, it being remembered that a proposed pleading is essential under 24(c);
4. That although the compulsory complaint in intervention in Appeal 16140 sought an injunction against Hartley to this Court's knowledge, and as referred to in its opinion, the relief sought was outside the jurisdiction of the District Court, and this Court did not intend to hold or to imply that intervenor had the right to file that complaint.

Hartley's contentions are interesting. They are unsound.

If they are to control when would there be an end to litigation?



IV

HARTLEY CONTENDS:

NOTWITHSTANDING THE EXPRESS PROVISIONS OF ITS LICENSE AGREEMENT PROHIBITING DISCLOSURE OF THE TRADE SECRET IT HAS THE RIGHT TO DISCLOSE AND THIS "WAS PATENTLY ANTICIPATED BY HARTLEY AND THE INTERVENORS". (Hartley Reply Brief, p. 24).

The right of the owner of a trade secret to enforce the maintenance of secrecy upon those to whom it has been disclosed in secret or under contract is set forth in Intervenor's Brief in No. 17741 at pages 6-8.

Hartley frequently reasserts in its brief that it has the right to disclose notwithstanding the express denial of that right in the license agreement (App. pp. 63-65).

There is one fatal weakness in the Hartley position. Contracts are binding. Hartley finds no law to support its position, nor can Intervenor.

It is denied that it was "patently anticipated", or otherwise, that Hartley should have the right to disclose. Any exceptions to the prohibition of the written agreement should be expressed with the same preciseness as the prohibition itself, and should have the same clarity and weight.

The Hartley position is untenable.



HARTLEY CONTENDS:

"HARTLEY COULD HAVE LONG AGO DISCLOSED IN THE MAIN ACTION (PRIOR TO THIS COURT'S INJUNCTION AGAINST IT ON FEBRUARY 2, 1962) WITH NO OTHER CONSEQUENCE THAN FORMULABS' SUIT, IF ANY, TO CLAIM DAMAGES THEREFOR." (Hartley Brief, p. 33).

The facts:

Intervention was brought to prevent the disclosure of the trade secret under the order of the District Court.

Prior to the first appeal, 16140, Mr. Falcone, counsel for Hartley, stated to Mr. Sellers, counsel for Formulabs, that Hartley would never disclose the secret to du Pont until after it had exhausted its legal remedy in the highest court. That statement and assurance was accepted by Intervenors' counsel on behalf of Intervenors and is still relied upon. Hartley cannot disclose without Mr. Falcone's breaking his word and as to that Intervenors and their counsel are not concerned. We may question Mr. Falcone's position. We may contend his reasoning is undisciplined and confused. We do not question his integrity.

Had the facts not been as here recited, Intervenors would not have been content to have the District Court pigeonhole their motion for a preliminary injunction from August 9, 1961, to July 31, 1962. Mr. Falcone knows this and has not forgotten his promise. The statement made in the heading of this section, therefore, is misleading.



VI

HARTLEY CONTENDS:

THIS COURT AUTHORIZED INTERVENTION IN APPEAL 16140 " . . . BUT HOW OR BY WHAT PLEADING IT DID NOT DECIDE. THERE WAS NO PLEADING ISSUE BEFORE THIS COURT AND THIS COURT DID NOT DETERMINE ANY PLEADING ISSUE. "
(Hartley Brief, p. 37).

Here we have confusion.

In its answering brief at page 16, as discussed above under Title III, Hartley alleged that it contended before this Court in Appeal 16140 that "the cross-complaint was insufficient". Now on page 37, as quoted above, it states the issue was not raised.

In considering this question the Court should have in mind the following:

1. FRCP 24(c) requires that an intervenor with his motion to intervene file a proposed complaint.

2. The law, as cited by Hartley in its Petition for Rehearing in Appeal No. 16140, and as referred to at greater length hereinafter under Title IX (p. 23 of this Brief), is that:

"The claimant for intervention must state a good claim on which relief can be granted. "

3. This Court was advised by du Pont in its Brief in Appeal 16140 at page 10:

"It is clear that Formulabs' sole objective in seeking to intervene was to obtain an injunction



restraining Hartley from disclosing certain trade secrets.

"If Formulabs' sole objective in seeking to intervene was to obtain something to which it was not lawfully entitled, then the order denying intervention was proper."

4. This Court was advised by Hartley in its Brief in Appeal 16140 at page 20:

" . . . That Formulabs 'herein seeks to have plaintiff enjoined from the disclosure' of its trade secrets (78); Formulabs prayed 'for judgment and an injunction enjoining plaintiff herein from disclosing to defendant . . . ' " (Emphasis was present.)

5. And at page 32:

" . . . Formulabs sought to intervene not against the Court's order of disclosure, nor against defendant who requested the disclosure, but strangely against plaintiff by asking the same Court to enjoin plaintiff from obeying the Court's order to disclose. " (Emphasis was present.)

"There is no such authority and such procedure is devoid of any logical or legal support. "

And at page 58:

"Plaintiff points out that Formulabs' motion and proposed cross-complaint were predicated on the controversy which it sought to create between itself and plaintiff and did not attack the order or defendant for seeking it. " (Emphasis was present.)



And the Hartley Brief in 16140 at page 65:

"The motion (to intervene) must set forth the grounds for intervention and shall be accompanied by a pleading setting forth the claim or defense for which the intervention is sought. Rule 24(c)."

And at page 67:

"As noted . . . Formulabs sought to enjoin plaintiff from disclosure, praying judgment against plaintiff." (Emphasis was present.)

If this Court had one fact forcefully and repeatedly called to its attention in 16140 it was the thrust of the proposed complaint in intervention.

How could it have held intervention was proper without accepting the proposed complaint?



VII

HARTLEY CONTENDS:

"AS TO THE INTERVENORS' REPEATED CONTENTIONS THAT THEY WERE DENIED DUE PROCESS BECAUSE THE COURT DISMISSED THEIR COMPLAINT IN INTERVENTION AND DENIED THE MOTION FOR PRELIMINARY INJUNCTION, HARTLEY SUBMITS THAT THEIR CONTENTIONS ARE PATENTLY WITHOUT ANY MERIT AT ALL."

(Hartley Brief, p. 42)

Intervenors' position in this connection is set forth in their Brief, Title 2, pages 21-24, entitled "The District Court Erred in Holding, in Violation of Intervenors' Property Rights and Their Right to Due Process under the Constitution, that Intervenors' Sole Right in Protecting Their Property is to Join Hartley in a 'Me Too' Position Opposing Du Pont's Effort to Show 'Good Cause' Justifying Discovery."

It is the denial by the District Court of Intervenors' right to assert their property rights, while concurrently asserting jurisdiction over that property and disposing of it, that violates Intervenors' property rights and their right to due process, both under the Constitution. Intervenors have been denied their day in court to assert their property rights. Dismissing their complaint and refusing to hear their claim for lack of jurisdiction, coupled with the taking of their property, is not due process.

Hartley earlier in its Brief in Appeal 16140, at page 51, asserted the correct law and as follows:

"Whatever else may be uncertain about the

definition of "due process", all authorities agree that it inhibits the taking of one man's property and giving it to another contrary to settled usages and modes of procedure, and without notice or an opportunity for a hearing. ' O'Choa v. Hernandez, 230 U. S. 139, 161. " (underlining added).

(Hartley Brief, Appeal 16140, p. 51)

VIII

HARTLEY CONTENDS:

"THE INTERVENORS STATE (14) 'THE OWNERSHIP RIGHTS OF INTERVENORS ARE UNCONTESTED. '

"HARTLEY STATES THAT THIS IS NOT SO. HARTLEY HAS SERIOUSLY QUESTIONED THIS . . ."

(Hartley Brief, p. 45)

The confusion Hartley has produced in this contention is set forth above under Title II.

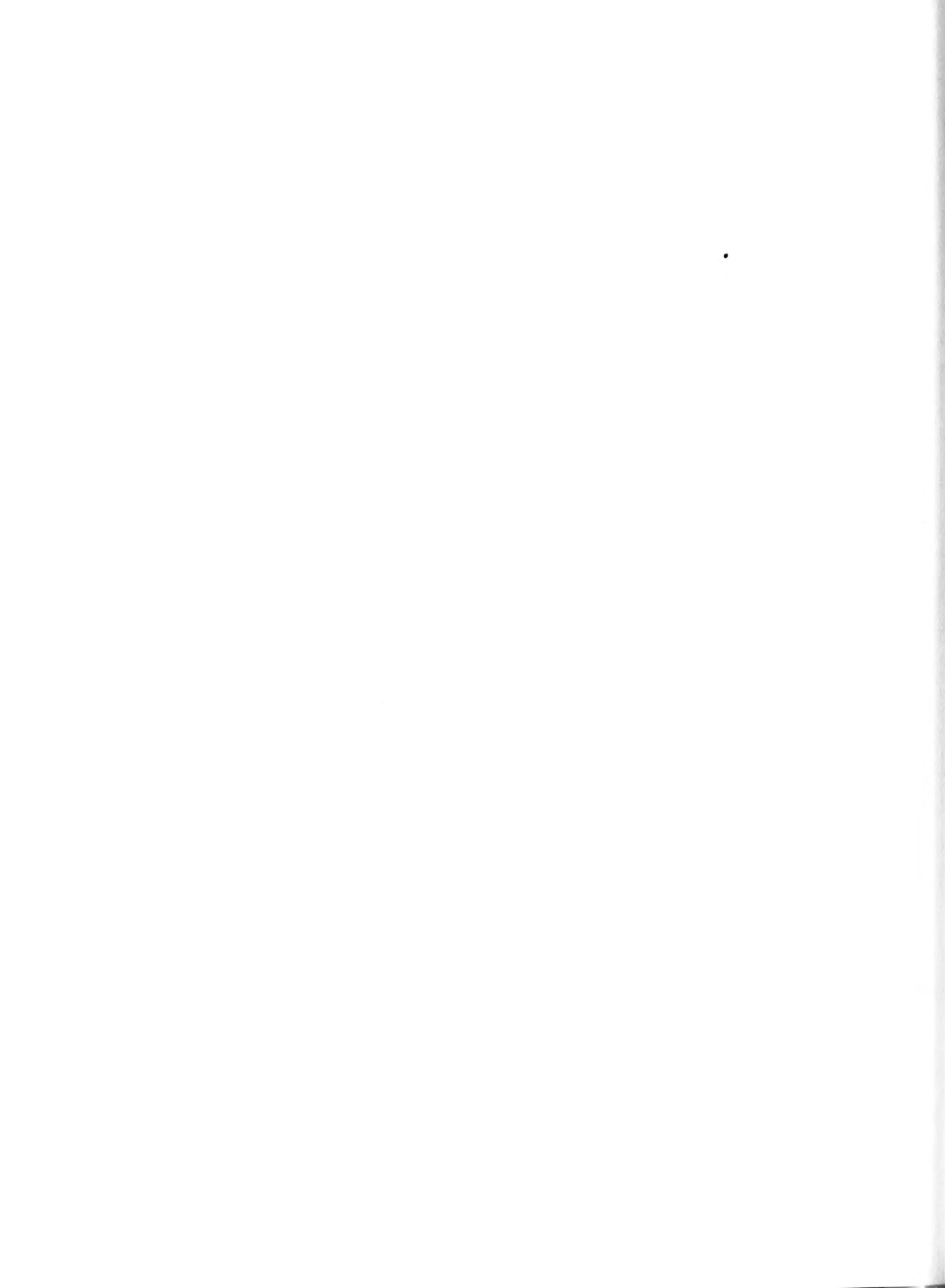

IX

HARTLEY CONTENDS:

"THE INTERVENORS CONFUSEDLY ARGUE (17-20) THAT NO DIVERSITY IS REQUIRED TO INTERVENE UNDER FRCP 24(a)(3) AND THAT THIS WAS ESTABLISHED BY THIS COURT IN 275 F.2d 52.

"HARTLEY ADMITS THAT NO DIVERSITY IS REQUIRED TO INTERVENE UNDER 24(a)(3) UNDER PROPER CIRCUMSTANCES AND UPON A PROPER RECORD."
(Emphasis added)

(Hartley Brief, p. 48)

Confused? Proper circumstances? Proper record?

Intervenors' argument referred to is found under the title

"The District Court Erred in Holding It Had No Jurisdiction of Intervenors' Complaint in Intervention", pp. 13-20.

The complaint filed in the District Court with the motion to intervene, the complaint before this Court in Appeal 16140 in which this Court held the right to intervene was present, and the present Complaint in Intervention, all make the same claim and seek the same relief.

What circumstance could be more "proper" than to file a complaint in intervention after the right to intervene had been sustained by the Court of Appeals?

What record could be more "proper" than a complaint in intervention filed under the compulsory requirement of FRCP 24(c), presented to this Court as a part of the record on appeal in Appeal 16140 to determine the right to intervene, and filed in the District Court after that right was sustained. The present



complaint is an amendment to that original complaint, makes the same claim against the plaintiff Hartley only, as did the original complaint, and seeks injunctive relief against Hartley only as did the original claim.

A more "proper record" under more "proper circumstances" would be hard to imagine.

X

HARTLEY CONTENDS:

RELATIVE TO INTERVENORS' STATEMENT ON PAGE 26 OF THEIR BRIEF THAT "NO OBJECTION WAS MADE BY ANY PARTY TO THAT FIRST APPEAL THAT THE COMPLAINT IN INTERVENTION WAS IMPROPERLY DIRECTED AGAINST HARTLEY ALONE", THAT:

"THIS IS A COMPLETELY INCORRECT STATEMENT OF THE RECORD. HARTLEY NOT ONLY OBJECTED BUT EMPHASIZED THE ABSURDITY OF THE CONTENTION THAT JUDGE HARRISON COULD ORDER DISCLOSURE (FORMULABS SO STATED) AND COULD THEN, AT FORMULABS' REQUEST, ORDER HARTLEY NOT TO OBEY HIS OWN ORDER TO DISCLOSE!"

(Hartley Brief, p. 55)

Hartley is correct.

In preparing the Opening Brief, Intervenor's counsel recalled that Hartley contended the District Court would not grant the relief sought and that the complaint should be directed against du Pont, but that is not the same as saying the Intervenor could not direct the complaint against Hartley alone if it so elected.

Since receiving Hartley's Brief, Intervenor's counsel has



reviewed the record and wishes to acknowledge error and to apologize for the statement which is inaccurate. Hartley did object to the proposed claim in intervention.

Intervenor made its incorrect statement here in connection with its contention of res judicata and cited the Partmar Corp. v. Paramount Pictures Theatres Corp. et al. (S. Ct. 1953), 347 U. S. 89, 74 S. Ct. 414, in support of the contention that even though the issue was not raised the doctrine of res judicata applied for it might have been raised.

The fact that the issue was actually raised, as pointed out by Hartley, strengthens Intervenor's position for if the issue was raised it must have been decided in Intervenor's favor for this Court held the right to intervene was present.

In its "Petition of Appellee Hartley Pen Company for Rehearing" in 16140 Hartley said:

"The only basis this Court has to decide Formulabs' right is to consider (as it did) its motion and cross-complaint."

(Hartley Pet. for Rehearing in Appeal 16140, p. 7)

"Rule 24(c) requires the claimant for intervention to state the grounds of his motion and to accompany it with a pleading setting forth the claim or defense for which the intervention is sought.

"This clearly requires the statement of a good claim.

"2 Barron & Holtzoff, Federal Practice and Procedure, §603, p. 233, no. 99;



4 Moore's Federal Practice, §24.14, p. 101, n. 1

"The claimant for intervention must state a good claim on which relief can be granted.

Shurtz v. Foster & Kleiser (D. C. Cal. 1939), 29

F. S. 162; 2 Barron & Holtzoff, p. 233, n. 99."

(Hartley Pet. for Rehearing in Appeal 16140, p. 7)

"Such a cross-complaint does not state the required claim or defense against either party."

(Hartley Pet. for Rehearing in Appeal 16140, p. 8)

". . . it [the District Court] might construe to be the direct or inferred mandate of this Court's decision that it should do so [order Hartley not to disclose] since it may be contended that this Court held that Formulabs is entitled to intervene upon its present cross-complaint." (Parenthetical matter added).

(Hartley Pet. for Rehearing in Appeal 16140, p. 9)

"This blanket qualification of Formulabs as a claimant for intervention as a matter of right, may lead to the contention that since its right to intervene was (and could only be) based upon its documents and procedure therefor, including the cross-complaint, this Court has held that the cross-complaint states a 'claim' or cause of action."

(Hartley Pet. for Rehearing in Appeal 16140, p. 12)

"If its decision continues unqualified, it may be contended that it held . . . that Formulabs' cross-



complaint states a cause of action or claim for the relief it requests, i. e., that it is proper, . . . "

(Hartley Pet. for Rehearing in Appeal No. 16140,
p. 14)

"If its decision remains unqualified, it will permit Formulabs to litigate in the main action an entirely separate cause of action, if any, i. e., a cause of action against petitioner predicated upon its contract with petitioner, which is completely foreign to the issues tendered in the main action. "

(Hartley Pet. for Rehearing in Appeal No. 16140,
p. 15)

Intervenors' position has been strengthened.

XI

HARTLEY CONTENDS:

"THE PLEADING IN THIS APPEAL, I. E., INTERVENORS' 'COMPLAINT IN INTERVENTION', IS DIFFERENT FROM FORMULABS' CROSS-COMPLAINT IN 16140. "

(Hartley Brief, pp. 57, 58)

Hartley makes this statement in arguing that Intervenors are not entitled to file their present complaint under the law of the case.

The original complaint present in Appeal 16140 is found at pp. 75-81 of the Transcript of Record in that appeal.

The present complaint in this Appeal 18180 is found at

App. pp. 58-65.

In each complaint it is alleged the ink formula is the subject matter, disclosure to Hartley in confidence and under the contract is recited, a copy of the agreement is attached, and an injunction is sought. Intervenors Schreur and Lacy here join the original intervenor in Appeal 16140.

By early Appeal 16140 the right was gained by the intervenor Formulabs to intervene with respect to the same cause of action seeking the same relief as the present complaint.

XII

HARTLEY'S ARGUMENT (HARTLEY BRIEF, pp. 71-75).

The Hartley Argument presents nothing not previously covered.

The matter of the District Court order filed September 21, 1961, signed September 11, 1961, and backdated to July 31, 1961, (Hartley Brief, pp. 71, 72) is discussed above under Title I at page 6.

The matter of the alleged overlooking of Hartley's rights, again referred to at page 73, is covered under Title II of this Brief at page 10.

The reference to the right of Intervenors on page 73 to prevent the unpermitted disclosure of their secret and the potential injury to Intervenors present nothing new.

The repeated allegation that the parties to the license

1911

1912

1913

1914

1915

1916

1917

1918

1919

1920

1921

1922

1923

1924

1925

1926

1927

1928

1929

1930

1931

1932

1933

1934

1935

agreement contemplated disclosure contrary to its express provisions is repeated on page 73, was earlier alleged, and is disposed of at Title II, page 10, of this Brief.

Hartley's Argument at page 74 refers to "the absurd statements of the intervenors" and alleges "the intervenors ignore every basic concept of intervention." Hartley's entire Argument cites one case, Hurn v. Ousler, 289 U.S. 238, 77 L. Ed. 1148, 53 S. Ct. 586, having nothing to do with intervention under FRCP 24(a)(3) to protect property in the custody of and under the control of the Court.

The Hartley Argument adds nothing constructive to the Hartley position.

CONCLUSION

The Hartley answering Brief is of little aid to its position being directed largely to repetitious argument based upon Hartley's unsupported opinions.

Dated: January 22 , 1963.

Respectfully submitted,

/s/ William Douglas Sellers

William Douglas Sellers

Attorney for Appellants
Formulabs, Incorporated
Clarence Schreur and
Gordon S. Lacy, dba
Pacific Research Laboratory

1880

1881

1882

1883

1884

1885

1886

1887

1888

1889

1890

1891

1892

1893

1894

1895

1896

1897

1898

1899

1900

No. 18180

IN THE UNITED STATES COURT OF APPEALS
FOR THE NINTH CIRCUIT

FORMULABS, INCORPORATED, a corporation,
CLARENCE SCHREUR and GORDON S. LACY,
individuals doing business as PACIFIC
RESEARCH LABORATORY, a co-partnership,

Appellants,

vs.

HARTLEY PEN COMPANY, a corporation,
doing business as THE HARTLEY CO., and
E. I. du PONT de NEMOURS & COMPANY,
a corporation,

Appellees.

INTERVENORS' BRIEF
IN REPLY TO ANSWERING BRIEF OF
APPELLEE E. I. du PONT de NEMOURS & COMPANY

WILLIAM DOUGLAS SELLERS
16 North Marengo Avenue
Pasadena, California

Attorney for Appellants
Formulabs, Incorporated,
Clarence Schreur and
Gordon S. Lacy, dba
Pacific Research Laboratory



No. 18180

IN THE UNITED STATES COURT OF APPEALS
FOR THE NINTH CIRCUIT

FORMULABS, INCORPORATED, a corporation,
CLARENCE SCHREUR and GORDON S. LACY,
individuals doing business as PACIFIC
RESEARCH LABORATORY, a co-partnership,

Appellants,

vs.

HARTLEY PEN COMPANY, a corporation,
doing business as THE HARTLEY CO., and
E. I. du PONT de NEMOURS & COMPANY,
a corporation,

Appellees.

INTERVENORS' BRIEF
IN REPLY TO ANSWERING BRIEF OF
APPELLEE E. I. du PONT de NEMOURS & COMPANY

WILLIAM DOUGLAS SELLERS
16 North Marengo Avenue
Pasadena, California

Attorney for Appellants
Formulabs, Incorporated,
Clarence Schreur and
Gordon S. Lacy, dba
Pacific Research Laboratory



TOPICAL INDEX

| | <u>Page</u> |
|---|-------------|
| INTRODUCTION | 1 |
| SUMMARY OF ARGUMENT | 2 |
| ARGUMENT | 3 |
| INTERVENORS' REPLY TO THE APPELLEE'S CONTENTION: | |
| I. "THE DISTRICT COURT DOES NOT HAVE SUBJECT MATTER JURISDICTION OVER THE SEPARATE AND INDEPENDENT CONTROVERSY FRAMED BY THE COM- PLAINT IN INTERVENTION. ITS DISMIS- SAL BY THE DISTRICT COURT WAS, THEREFORE, A NECESSARY AND PROPER RESULT. " | 3 |
| II. "ASSUMING ARGUENDO THAT JURISDICTION OF THE DISTRICT COURT EXTENDS TO DETERMINATION OF THE SEPARATE AND INDEPENDENT CONTRO- VERSY FRAMED BY THE COMPLAINT IN INTERVENTION, THE DISTRICT COURT DID NOT ABUSE ITS DISCRETION IN REFUSING TO ENJOIN DISCLOSURE BY HARTLEY. | |
| "A. THE PRESENTATION OF THE TRUTH IS A PARAMOUNT CONSIDERATION TO PROTECTION OF A PROPRIETARY RIGHT. " | 12 |
| III. "B. UNDER THE CONDITIONS OF SAFE- GUARD INCORPORATED IN THE ORDER OF LIMITED DISCLOSURE, NO GENERAL PUBLICATION OF THE SECRETS WILL BE MADE AND NO IRREPARABLE INJURY DONE TO INTERVENORS. " | 17 |
| CONCLUSION | 20 |

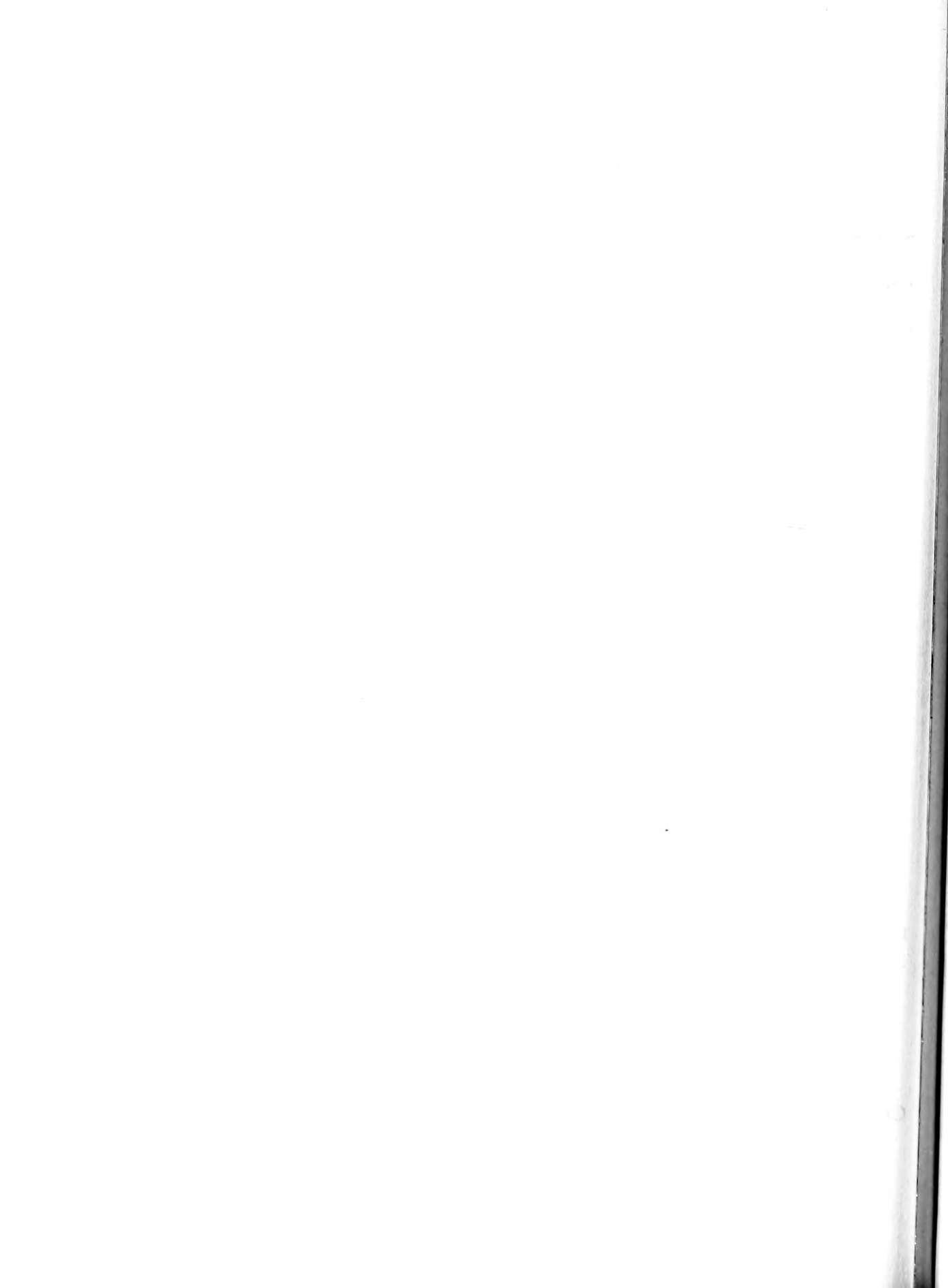
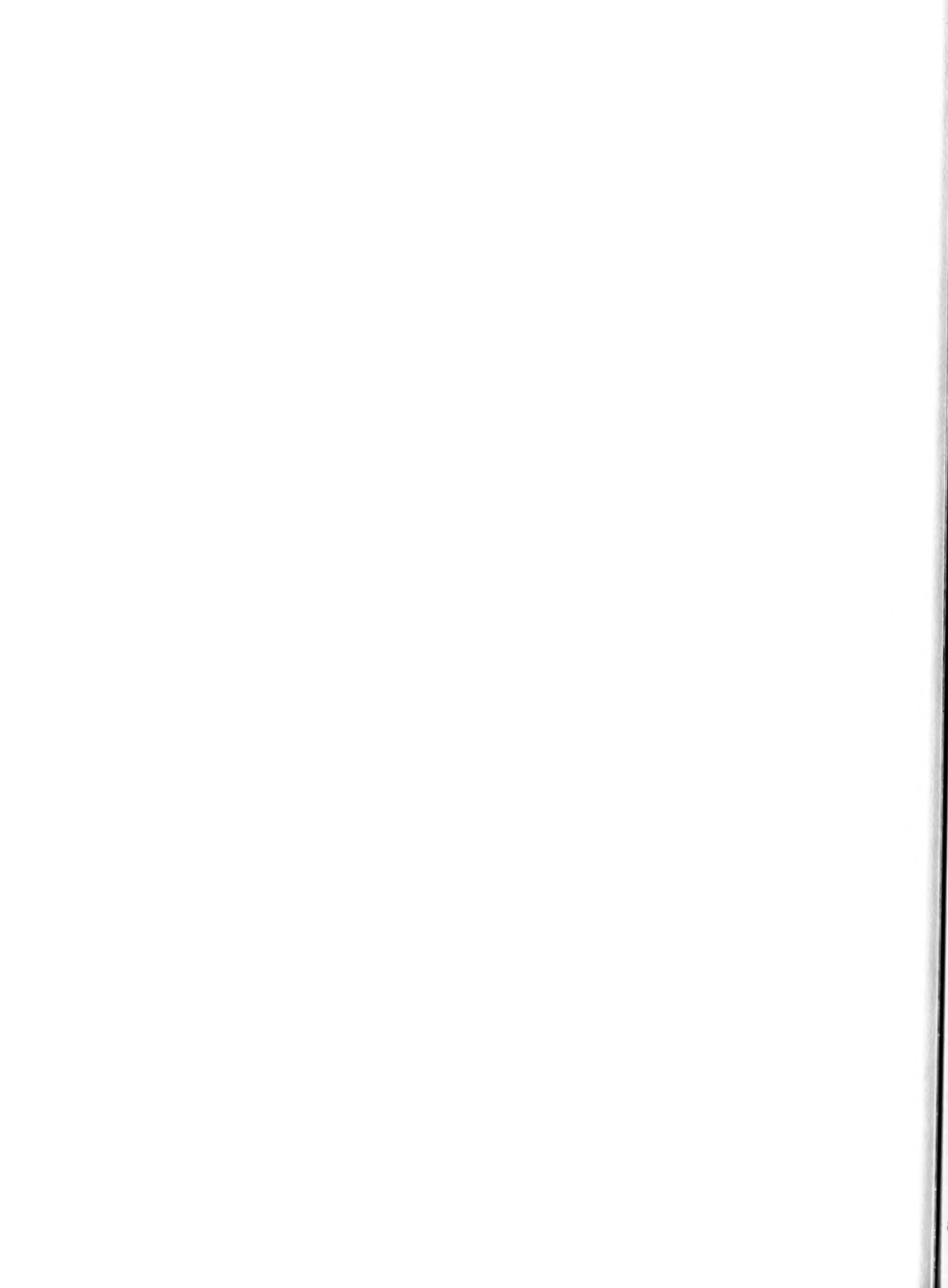

TABLE OF AUTHORITIES CITED

| <u>Cases</u> | <u>Page</u> |
|--|-------------|
| Chadwick v. Covell (1890) 151 Mass. 1900, 23 N. E. Rep. 1068 | 11 |
| Formulabs, Inc. v. Hartley Pen Co., 275 Fed.2d 52 | 4 |
| Giblett v. Read (Hardwick, Ld. Ch., 1743) 9 Mod. 459 | 10 |
| Krippendorf v. Hyde, 110 U.S. 276 | 4, 8 |
| Stewart v. Hook, 118 Ga. 445, 45 S. E. 369, 63 L. R. A. 255 | 10 |
| Vulcan Detinning Co. v. American Can Co. (1904) 67 N. J. Eq. 243, 58 Atl. 290 | 10 |

Rules

| | |
|---------------|-----------|
| FRCP 24(a)(3) | 3, 11, 20 |
|---------------|-----------|



No. 18180

IN THE UNITED STATES COURT OF APPEALS
FOR THE NINTH CIRCUIT

FORMULABS, INCORPORATED, a corporation,
CLARENCE SCHREUR and GORDON S. LACY,
individuals doing business as PACIFIC
RESEARCH LABORATORY, a co-partnership,

Appellants,

vs.

HARTLEY PEN COMPANY, a corporation,
doing business as THE HARTLEY CO., and
E. I. du PONT de NEMOURS & COMPANY,
a corporation,

Appellees.

INTERVENORS' BRIEF
IN REPLY TO ANSWERING BRIEF OF
APPELLEE E. I. du PONT de NEMOURS & COMPANY

INTRODUCTION

This brief is in reply to the Answering Brief of the appellee E. I. du Pont de Nemours & Company and the argument herein is arranged in parallelism with the argument of that appellee.

The parties and the various parts of the record are identified in the manner stated in Intervenor's Brief at pages 2 and 3.

E.

ar

ide

anc

No. 18180

IN THE UNITED STATES COURT OF APPEALS
FOR THE NINTH CIRCUIT

FORMULABS, INCORPORATED, a corporation,
CLARENCE SCHREUR and GORDON S. LACY,
individuals doing business as PACIFIC
RESEARCH LABORATORY, a co-partnership,

Appellants,

vs.

HARTLEY PEN COMPANY, a corporation,
doing business as THE HARTLEY CO., and
E. I. du PONT de NEMOURS & COMPANY,
a corporation,

Appellees.

INTERVENORS' BRIEF
IN REPLY TO ANSWERING BRIEF OF
APPELLEE E. I. du PONT de NEMOURS & COMPANY

INTRODUCTION

This brief is in reply to the Answering Brief of the appellee E. I. du Pont de Nemours & Company and the argument herein is arranged in parallelism with the argument of that appellee.

The parties and the various parts of the record are identified in the manner stated in Intervenor's' Brief at pages 2 and 3.

I

N

SUMMARY OF ARGUMENT

I

INTERVENORS' REPLY TO THE APPELLEE'S CONTENTION:

"THE DISTRICT COURT DOES NOT HAVE SUBJECT MATTER JURISDICTION OVER THE SEPARATE AND INDEPENDENT CONTROVERSY FRAMED BY THE COMPLAINT IN INTERVENTION. ITS DISMISSAL BY THE DISTRICT COURT WAS, THEREFORE, A NECESSARY AND PROPER RESULT."

II

INTERVENORS' REPLY TO THE DU PONT CONTENTION:

"ASSUMING ARGUENDO THAT JURISDICTION OF THE DISTRICT COURT EXTENDS TO DETERMINATION OF THE SEPARATE AND INDEPENDENT CONTROVERSY FRAMED BY THE COMPLAINT IN INTERVENTION, THE DISTRICT COURT DID NOT ABUSE ITS DISCRETION IN REFUSING TO ENJOIN DISCLOSURE BY HARTLEY.

"A. THE PRESENTATION OF THE TRUTH IS A PARAMOUNT CONSIDERATION TO PROTECTION OF A PROPRIETARY RIGHT."

INTERVENORS' REPLY TO DU PONT ARGUMENT II B:

"B. UNDER THE CONDITIONS OF SAFEGUARD INCORPORATED IN THE ORDER OF LIMITED DISCLOSURE, NO GENERAL PUBLICATION OF THE SECRETS WILL BE MADE AND NO IRREPARABLE INJURY DONE TO INTERVENORS."

F
v
li
a
li
of
lit
to

ARGUMENT

INTERVENORS' REPLY TO THE APPELLEE'S CONTENTION:

"THE DISTRICT COURT DOES NOT HAVE SUBJECT MATTER JURISDICTION OVER THE SEPARATE AND INDEPENDENT CONTROVERSY FRAMED BY THE COMPLAINT IN INTERVENTION. ITS DISMISSAL BY THE DISTRICT COURT WAS, THEREFORE, A NECESSARY AND PROPER RESULT. "

1. Du Pont states:

"By their complaint in intervention, intervenors sought to litigate in the federal forum their rights and the correlative duties of Hartley under a licensing agreement made between them and Hartley. "

(du Pont Brief, page 7).

This is misleading.

Intervenors intervened to protect their property under FRCP 24(a)(3). That property was before the District Court by virtue of the fact it was in the possession of Hartley, one of the litigants.

The existence of the agreement and its continued validity are not denied by Hartley.

Intervenors intervened to protect their property. The license agreement is evidence which will be used in the assertion of their rights. It is incorrect to say that they intervened to litigate the relative rights between themselves and Hartley, but to the extent that is necessary it would be the duty of the District

of
ag
2
is

Court to determine that issue just as though Intervenors were asserting rights to physical property in the possession of the Court as in Krippendorf v. Hyde, 110 U.S. 276.

2. Du Pont, after discussing Krippendorf v. Hyde, upon which Intervenors rely and which was recognized by this Court in the first Formulabs' appeal as being controlling law, see Formulabs, Inc. v. Hartley Pen Co., 275 F.2d 52, certiorari denied, 363 U.S. 830, attempts to distinguish the present case and contends:

"In the present case, by contrast, neither Hartley nor du Pont disputes intervenors' claimed proprietary rights or asserts any paramount interest (or in the case of du Pont, any interest at all) in the secret ballpen ink formulae."

(du Pont Brief, page 10, lines 1-5).

It is true, here, as in Krippendorf v. Hyde, the ownership of the intervenors is acknowledged. In addition in this case the agreement, which is also acknowledged, upon its face at paragraph 2 spells out the obligations of Hartley to maintain the secrecy. It is not denied, nor can it be at this time. Paragraph 2 is as follows:

"(2) The second party (Hartley) undertakes and agrees that it will not in any way or manner make known, divulge or communicate the secret of said formula to any person or persons whomsoever, and will take all reasonable precautions against the secret of said formula being

b.

H

th

M

Ha

learned or acquired by an unauthorized person or persons. "

(App. pp. 63-65).

The ownership of the property is admitted, the existence of the binding agreement is admitted, but it appears to be the du Pont position that the Court cannot consider any evidence which establishes or measures Intervenors' proprietary rights.

The right to intervene is obviously a hollow right if after intervening Intervenors are denied the right to assert their proprietary interest.

3. Du Pont makes the following erroneous statement:

"The district court has acquired control over the secrets, not through court process, but by virtue of a licensing agreement willingly made by intervenors prior to the occurrence of the events destined to be litigated between the principal adversaries, Hartley and du Pont. "

(du Pont Brief, page 10, lines 5-10).

The fact is the District Court had jurisdiction of the secret by virtue of the fact the secret was in the possession of Hartley and Hartley was before the Court. It was Judge Harrison who said at the hearing on Monday, February 18, 1957, addressing himself to Mr. Falcone, attorney for Hartley:

"You are in this court with that formula. "

(Tr. p. 273 in Appeal No. 16140).

The order of the District Court to disclose is an order to Hartley to breach its agreement, a clear-cut interference with the

a

C

R

r

s

obligations of a valid and binding contract between the parties, made without giving to Intervenors the opportunity to assert their rights of ownership. That such is the case is clearly evidenced by the statement by counsel for Hartley at the hearing before Judge Harrison on February 18, 1957:

"MR. FALCONE: If you make such an order, your Honor, as we told you in conference in chambers, we will accede to it, but we are going contrary to our contract with our licensor."

(Tr. p. 272, Appeal No. 16140).

4. Du Pont contends:

"The owners of the secrets have not been in any way deprived of the use or possession of their property and are not threatened with such deprivation under the terms of the discovery order now before this court for review in Cause No. 17799."

(du Pont Brief, p. 10, lines 10-14).

This has been answered by Intervenors in their main Brief at pages 27-30, which includes by reference Intervenors' Brief in Cause No. 17741, pages 48-52.

Du Pont makes the same general argument at pages 14, 15. Reference is respectfully directed to pages 17 to 19 of this Brief replying thereto.

The extent of the injury resulting from the disclosure is speculative and uncertain. There is no way to guarantee Intervenors

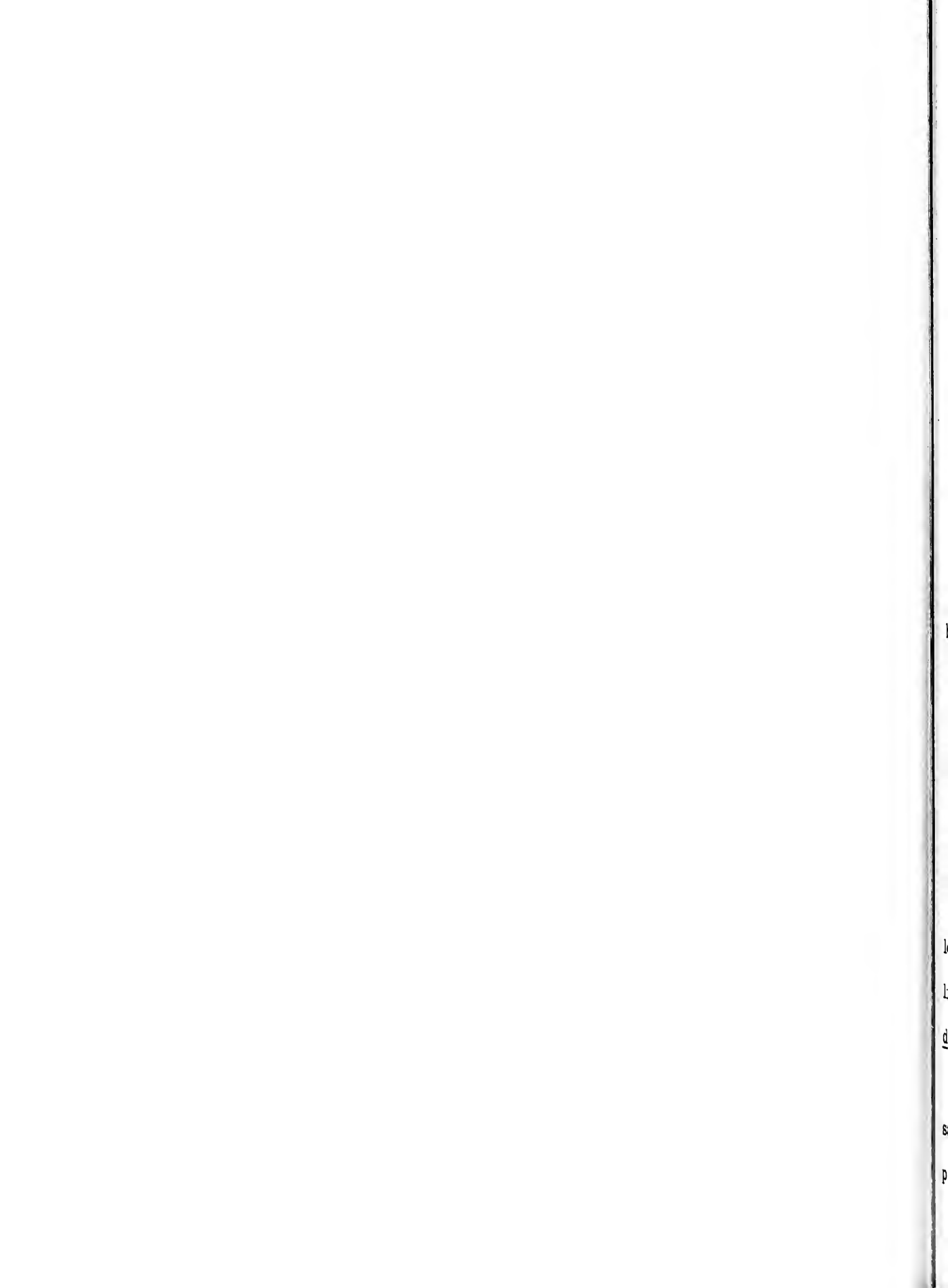

the protection to which they are entitled except to protect their secret.

Du Pont's position is: No harm will result from giving us the key to your treasurer's room. We are not removing the treasure at this time.

Intervenors' position is: You have no right to the treasure at any time. Unless you plan to remove the treasure from the storeroom at some time, and are permitted to do so, there is no justifiable reason for giving you the key now.

A little larceny cannot be justified upon the ground it is little.

5. Du Pont makes a contention, which is interesting because of the confusion it evidences, and as follows:

"Furthermore, if any threat to their (intervenors) property should hereafter arise, that threat would stem from the use of their property which intervenors themselves sanctioned in electing to license Hartley for royalty."

(du Pont Brief, p. 10, lines 14-18; emphasis added).

This statement can only be explained by assuming du Pont lost sight entirely of the fact that the agreement (App. pp. 63, 64) licensing Hartley to use the secret expressly bound Hartley not to disclose.

Du Pont is in the position of contending that Intervenors sanctioned the doing of something which their agreement expressly prohibited.

W
i
o
d
ve
pr
in
ma
Se
lic

6. Du Pont's confusion is further evidenced by its attempt to distinguish the present case from Krippendorf v. Hyde. It said:

"There an innocent third person found himself deprived of the use and possession of his property as a result of court process issued in aid of an action between two parties, neither of whom bore any relation to him. Unlike intervenors, Krippendorf had not voluntarily surrendered any part of his bundle of rights in the property attached. "

(du Pont Brief, p. 10, lines 24-30).

It is clear on the record that so far as the issues of the main case between Hartley and du Pont are concerned Intervenor are strangers and have no interest. The attempt to distinguish between Krippendorf v. Hyde and the present case in this manner is obviously unsound.

As to the contention that Intervenor have surrendered part of their rights, and so Krippendorf v. Hyde does not apply, that does not stand the light of analysis either. The right which Intervenor assert is the right to protect their secret, the right to prevent others from learning the secret, a right expressly provided in the license agreement with Hartley. Whatever rights Intervenor may have surrendered to Hartley did not include the right they here seek to protect which right was denied Hartley expressly by its license agreement. The du Pont contention is clearly without merit.

7. Du Pont contends:

"Here there are no conflicting claims of ownership of the secrets and no question but that Hartley's claim against du Pont arises out of its use under license of those secrets."

(du Pont Brief, p. 11, lines 1-4).

Just how this aids the du Pont position is not clear.

Here is an admission by du Pont that Intervenors own the secret and that Hartley is a licensee thereunder.

It was Hartley who brought this suit and to say that it gained the right to breach its own license agreement by the expedient of bringing a lawsuit against a third party is to sanction an escape from a binding contractual obligation by a self-serving act.

This is a strange contention for du Pont to make.

8. Du Pont makes the contention:

"Here, of course, intervenors have been extended the opportunity to oppose as owners, together with Hartley, the efforts of du Pont to establish need for limited disclosure of the secrets in order properly to prepare its defense to the main action. That opportunity they have fully exercised as owners." (Emphasis added).

(du Pont Brief, p. 11, Second Paragraph, lines 1-6).

This is misleading in the extreme. The District Court only permitted Intervenors to join Hartley in a "me too" position opposing the du Pont effort to show "good cause" justifying disclosure of the trade secret. They did not intervene for that purpose.

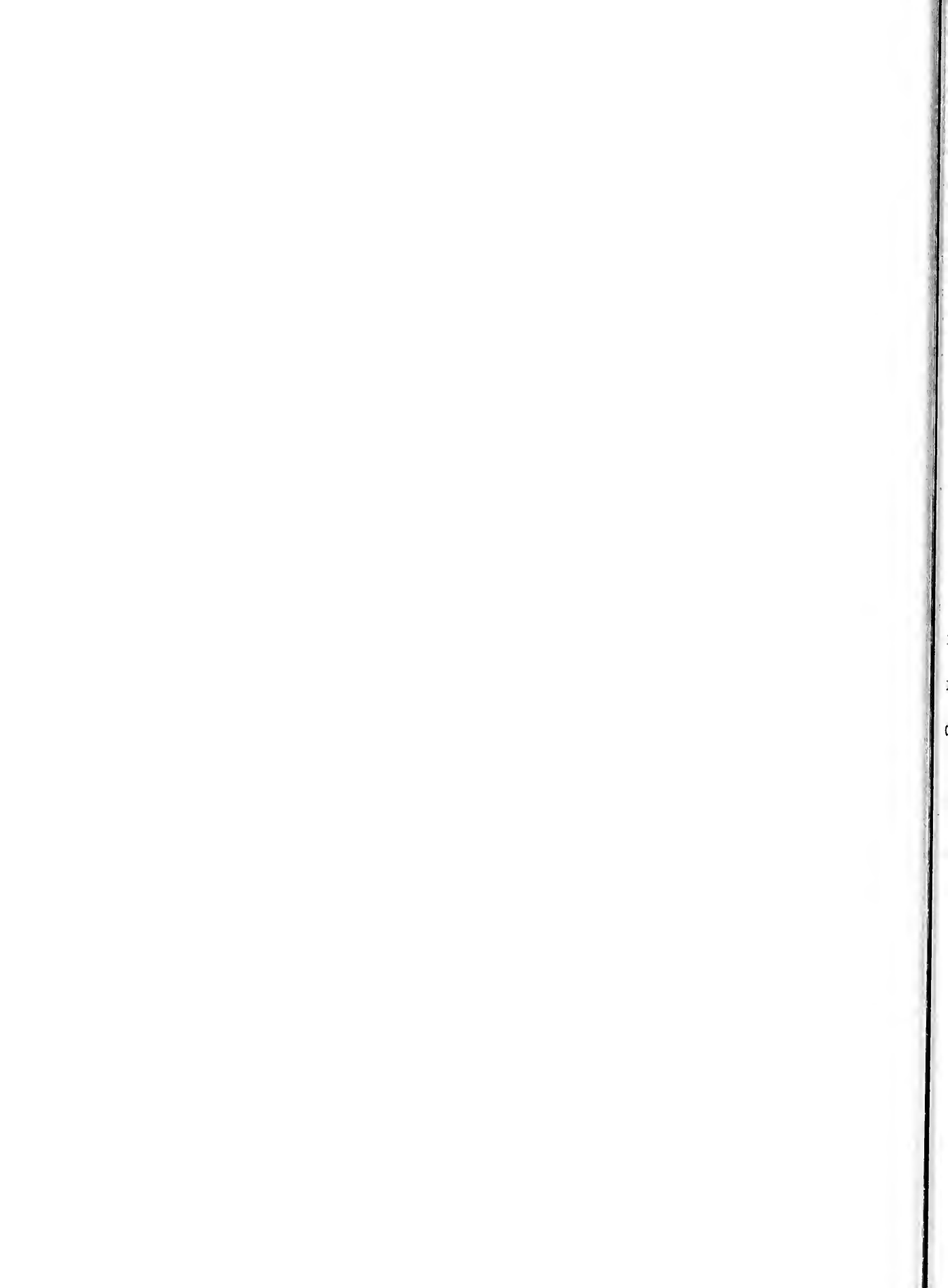

At no time were Intervenor permitted to establish their rights "as owners", or to assert any rights of ownership. The District Court at all times asserted and ruled it would not hear Intervenor as to their rights as owners, and as the record shows, refused to give to Intervenor their day in court in that connection, or even to act upon the motions to dismiss their complaint, until ordered by this Court to do so.

It is the opportunity to assert their rights as owners that Intervenor sought at all times and now seek. For du Pont to say that Intervenor have been given the right to intervene "as owners" is most misleading. That right was never given to Intervenor.

In making this contention du Pont clearly did not have in mind the law which only gives to an "owner" of a trade secret the right to assert his rights against one to whom the secret has been disclosed in confidence or under a contract.

"A valid patent protects its owner and his assignees and licensees against everyone infringing it, while a trade secret protects its owners only against those who have learned the secret under a contractual or confidential obligation to preserve the secrecy. "

Vulcan Detinning Co. v. American Can Co. (1904),

67 N. J. Eq. 243, 58 Atl. 290;

Giblett v. Read (Hardwick, Ld. Ch. , 1743),

9 Mod. 459;

Stewart v. Hook, 118 Ga. 445, 45 S. E. 369,

63 L. R. A. 255;

t
a
c
t:
2

Chadwick v. Covell (1890), 151 Mass. 1900,
23 N. E. Rep. 1068.

The disclosure was to Hartley, and as the record clearly shows, Intervenors have at all times been prevented by the District Court from asserting their rights against Hartley. Accordingly, Intervenors have never asserted rights "as owners". Please see in this connection Intervenors' Brief in No. 17741 at pages 6-8.

In conclusion, with respect to Intervenors' reply to the du Pont Point I, du Pont has said nothing to disturb the fact that Intervenors have the right to intervene under the law of this case; that, as owners of the trade secret, they intervened to protect, they should have the right to assert their ownership rights against the one party to whom the secret has been disclosed in confidence and who seeks to disclose that secret to others in violation of its contractual obligation and as the receiver of confidential information; and that the right to protect a trade secret under FRCP 24(a)(3) is recognized by this Court.

II.

INTERVENORS' REPLY TO THE DU PONT CONTENTION:

"ASSUMING ARGUENDO THAT JURISDICTION OF THE DISTRICT COURT EXTENDS TO DETERMINATION OF THE SEPARATE AND INDEPENDENT CONTROVERSY FRAMED BY THE COMPLAINT IN INTERVENTION, THE DISTRICT COURT DID NOT ABUSE ITS DISCRETION IN REFUSING TO ENJOIN DISCLOSURE BY HARTLEY.

"A. THE PRESENTATION OF THE TRUTH IS A PARAMOUNT CONSIDERATION TO PROTECTION OF A PROPRIETARY RIGHT. "

1. The contention that "The Presentation of the Truth Is a Paramount Consideration to Protection of a Proprietary Right" is a fine contention, one which would have appealed mightily to the ancient Greeks, but in the present case overlooks several very important facts. Among the foremost is the fact that the proprietary right to be protected here is the right of a third party, not the right of one of the parties engaged in the contentions as to what is and what is not truth. Another fact overlooked is that one of the truth seekers is bound by contract and by his obligations under a confidential disclosure not to say certain things in public for any reason, whether it be to establish truth or to satisfy a personal vindictive urge.

If du Pont wishes to argue in terms of ultimate good and philosophic concepts it should not lose sight of the concept of the sanctity of contracts. Hartley promised on its word of honor not to disclose Intervenors' secret. There was consideration for that

promise, it was good and binding. How does du Pont justify encouraging Hartley to break that promise simply to win an argument which it started with a third party?

Hartley is not obligated to establish "truth". It started the "argument" voluntarily. It can drop it voluntarily. It is not bound. It is bound, however, to recognize its binding contractual obligation not to disclose the trade secret.

2. Du Pont states:

" . . . if disclosure of the secrets is indispensable to that result, (determination of rights of litigants) then disclosure must be made. Coca-Cola Co. v. Joseph C. Wirthman Drug Co. , 48 F. 2d 743; Grasselli Chemical Co. v. National Aniline & Chem. Co. , 282 Fed. 379; Willson v. Superior Court, 66 Cal. App. 275, 225 Pac. 881. "

(du Pont Brief, p. 12, first full paragraph, last six lines [parenthetical matter inserted]).

The cases cited by du Pont do not apply for in each the party seeking to protect the trade secret was one of the litigants bringing or defending the action.

3. Du Pont also makes the contention:

"Another striking dissimilarity between Krippendorf and the present case stems from du Pont's need to know the secret formulae in order properly to prepare its defense to Hartley's claim. "



(du Pont Brief, p. 12, first full paragraph, lines 1-4).

Intervenors answered this in their main Brief at pages 34 and 35. The lower court stated that if Hartley did not disclose when ordered to do so du Pont would prevail. Hartley is presently ordered to disclose. If it fails to do so, in the absence of reversal of the lower court's order, du Pont would, of necessity, receive judgment upon the dismissal of the Hartley complaint. How, then, can it be contended by du Pont that it needs the formula? Du Pont will be the winner if it doesn't receive it. It could still lose if it does receive it.

4. Du Pont contends that Intervenors:

" . . . Having sought and presumably obtained a commercial advantage by revealing the secrets to Hartley under license, intervenors have not insulated themselves from that hazard. So to hold would be to frustrate public policy requiring disclosure where necessary in order to enable a defendant to prepare his defense. "

(du Pont Brief, p. 13, lines 3-7).

This contention entirely ignores two facts, to wit:

1. Disclosure was made to Hartley in confidence; and
2. Disclosure made to Hartley was under a contract which bound Hartley not to disclose to others.

Du Pont in effect is here contending that the contract licensing Hartley has no binding effect, and that Hartley can obtain the right to breach that contract unilaterally by bringing an action

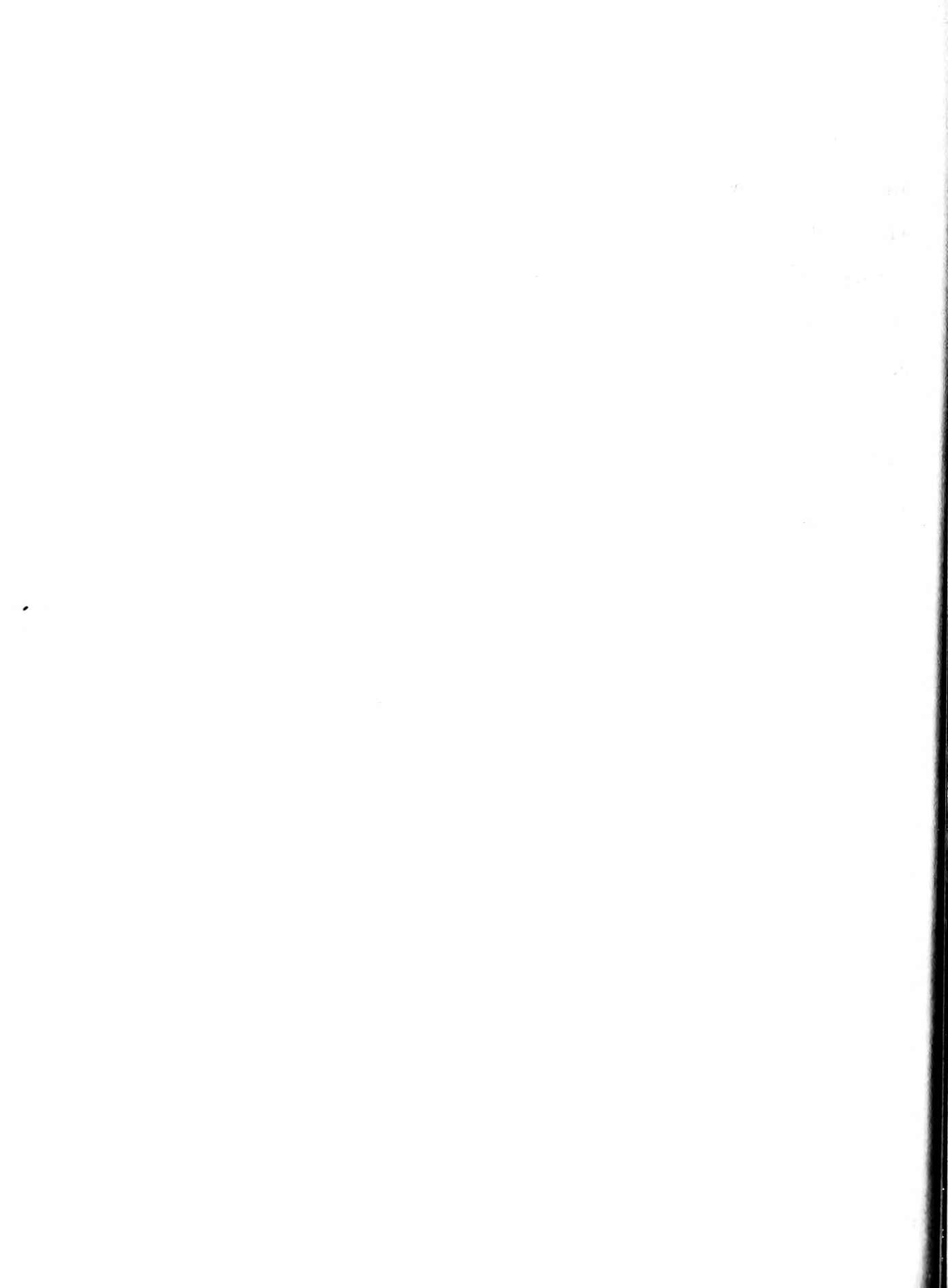

against a third party, du Pont.

Du Pont here asserts a "public policy requiring disclosure where necessary in order to enable a defendant to prepare his defense". In all honesty it does appear that du Pont's zeal in urging the primacy of "truth" and now of a "public policy" is most exercised when du Pont would be benefited by the acceptance of its views.

What about "public policy" requiring parties to a valid contract to recognize and honor their contractual obligations? What about a "public policy" requiring one who has received a confidential disclosure to honor the confidence? Du Pont remains silent on these but clearly they are present and in this case more controlling than any alleged "public policy" relating to a disclosure which du Pont doesn't need to win and which Hartley can make only by breaching its contractual obligations.

The du Pont position lacks some merit.

5. Du Pont also contends:

"That the secrets sought to be protected are the property of persons not parties to the action is not a proper consideration affecting the requirement of disclosure. Johnson Steel Street-Rail Co. vs. North Branch Steel Co., 48 Fed. 191, 192-93. "

(du Pont Brief, p. 13, lines 9-13).

Johnson Steel was an early case in 1891 and related to a subpoena duces tecum served upon a witness not a party to the

action. The case did not relate to the intervention by the owner of a valuable secret. The most interesting thing here is that du Pont found it necessary to rely upon a case decided in 1891 and could find nothing closer.

6. Du Pont contends that even though it be assumed the District Court has the power to determine Intervenors' rights: the "refusal of the injunction sought by intervenors did not constitute error."

The refusal of injunctive relief to Intervenors by the District Court premised upon position of the District Court that it had no jurisdiction makes good sense. The right of Intervenors to an injunction in the event the District Court is in error and it does in fact have jurisdiction of Intervenors' complaint has never been considered by the District Court.

Having determined it had no jurisdiction the District Court was in no position to rule upon the rights Intervenors would have if it had jurisdiction. No consideration nor weight was given to Intervenors' ownership rights. How could it be when the Court refused jurisdiction of the pleading in which they were asserted.

If this Court holds that the District Court has jurisdiction of Intervenors' complaint then their right to a preliminary injunction must be reevaluated in the light of their ownership rights not heretofore weighed.

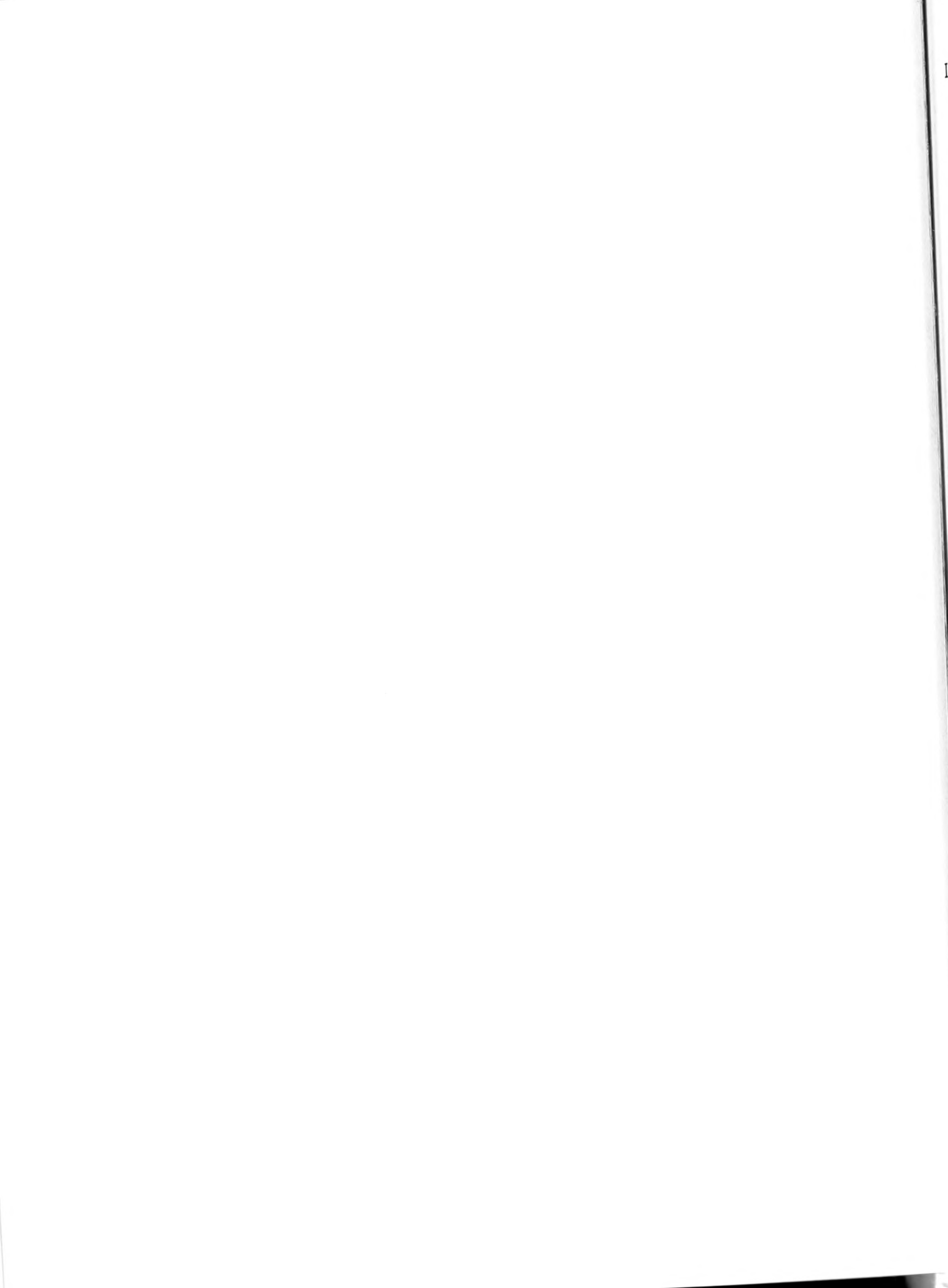

INTERVENORS' REPLY TO DU PONT ARGUMENT II B:

"B. UNDER THE CONDITIONS OF SAFEGUARD INCORPORATED IN THE ORDER OF LIMITED DISCLOSURE, NO GENERAL PUBLICATION OF THE SECRETS WILL BE MADE AND NO IRREPARABLE INJURY DONE TO INTERVENORS."

1. Reference is respectfully made to Intervenor's Brief in Appeal No. 17741, pages 48-52.

Either du Pont is to be given the formula to use for its own defense as needed in a jury trial or the disclosure cannot be justified upon any ground. Accordingly, it must be assumed that disclosure, having been once made to du Pont, will be used as needed for its defense. The matter of irreparable injury is discussed in Intervenor's Brief in No. 17741 at the point identified above.

It is something less than reasonable to assume that du Pont is to be given the opportunity to use the secret to prepare for its defense and then, at the last minute, when it is about to present its defense to the open court, to the jury, to the record, and to all present, suddenly the court will say: You cannot do this.

The practical fact is that the court would order the evidence admitted and before counsel for Intervenor could get out of the courtroom, much less file a paper with the Court of Appeals seeking relief, the damage would be done.

Unless property rights can be freely destroyed, contractual rights freely abrogated, and a litigant denied his day in court to

assert his rights, the order of the District Court ordering disclosure while denying to Intervenor an opportunity to be heard cannot, in the honest opinion of the Intervenor, be justified.

2. Du Pont makes a self-righteous assertion:

"No issue can seriously be tendered that du Pont will misuse the information disclosed pursuant to the order, either by a publication in contempt of the provisions of that very order or by the competitive manufacture of ballpen ink."

(du Pont Brief, p. 15, paragraph 1, last five lines).

The "du Pont" referred to is not an individual but a great many individuals who over a period of years will go in many directions and have many contacts under many diverse circumstances none of which, in all probability, can be traced or checked upon by the Intervenor.

It is extremely doubtful that du Pont as a corporation would knowingly violate the order of the Court, but that the individuals involved would not from time to time use the information obtained in diverse ways which might never be discovered is stating as a fact something that no one can know.

The point is that Intervenor are seeking to protect a trade secret worth one million dollars. Neither Du Pont nor anyone else is in any position to ask or to demand that they, the Intervenor, give up a Constitutional right to protect their property upon a speculative concept that "x" number of unknown individuals will

over an extended period of time diligently protect the secret once disclosed.

3. Du Pont makes the contention:

"That general publication of the secrets will follow their disclosure under the safeguards provided is apprehension on the part of intervenors, not fact."

(du Pont Brief, p. 15, paragraph 2, lines 7-9).

As stated above, if du Pont is not to be given the opportunity to use the trade secret in the defense of its case, once the secret is given to it, then disclosure cannot be justified in the first place. It is only upon the assumption and presumption that du Pont will be enabled to use the secret as necessary that there can be any possible logical grounds for disclosing to du Pont.

12.09.00

12.09.00

12

12

12

12

12

12.09.00

12.09.00

12.09.00

12.09.00

12.09.00

CONCLUSIONS

Du Pont, by its Answering Brief, has failed to establish a single sound reason justifying denial to Intervenors of their day in court to assert their property rights; or justifying the disclosure of their trade secret in the absence of their consent; or supporting any contention that they are not entitled under FRCP 24(a)(3) to assert their rights as owners; or justifying the denial to Intervenors of their property rights under the United States and California Constitutions.

Dated: January 17, 1963.

Respectfully submitted,

/s/ W. D. Sellers

WILLIAM DOUGLAS SELLERS

Attorney for Formulabs, Incorporated,
Clarence Schreur and Gordon S. Lacy.

CERTIFICATE

I certify that, in connection with the preparation of this Brief, I have examined Rules 18 and 19 of the United States Court of Appeals for the Ninth Circuit, and that, in my opinion, the foregoing brief is in full compliance with those rules.

/s/ W. D. Sellers

WILLIAM DOUGLAS SELLERS



No. 18180
IN THE

United States Court of Appeals

FOR THE NINTH CIRCUIT

FORMULABS, INCORPORATED, a corporation, CLARENCE SCHREUR and GORDON S. LACY, individuals doing business as PACIFIC RESEARCH LABORATORY, a co-partnership,

Appellants,

vs.

HARTLEY PEN COMPANY, a corporation, doing business as THE HARTLEY Co., and E. I. DU PONT DE NEMOURS & COMPANY, a corporation,

Appellees.

Answering Brief of Appellee E. I. du Pont
de Nemours & Company.

LAWLER, FELIX & HALL,
ROBERT HENIGSON,

800 Standard Oil Building,
605 West Olympic Boulevard,
Los Angeles 15, California,

*Attorneys for E. I. du Pont
de Nemours & Co.*



TOPICAL INDEX

| | PAGE |
|--|------|
| Statement showing jurisdiction..... | 1 |
| Statement of proceedings following remand..... | 3 |
| Summary of argument..... | 6 |
| Argument | 7 |

I.

| | |
|---|---|
| The District Court does not have subject matter jurisdiction over the separate and independent controversy framed by the complaint in intervention. Its dismissal by the District Court was, therefore, a necessary and proper result | 7 |
|---|---|

II.

| | |
|--|----|
| Assuming arguendo that jurisdiction of the District Court extends to determination of the separate and independent controversy framed by the complaint in intervention, the District Court did not abuse its discretion in refusing to enjoin disclosure by Hartley..... | 12 |
| A. The presentation of the truth is a paramount consideration to protection of a proprietary right..... | 12 |
| B. Under the conditions of safeguard incorporated in the order of limited disclosure, no general publication of the secrets will be made and no irreparable injury done to intervenors..... | 14 |
| Conclusion | 16 |

TABLE OF AUTHORITIES CITED

| CASES | PAGE |
|--|------------------|
| Coca-Cola Co. v. Joseph C. Wirthman Drug Co., 48 F. 2d 743 | 12 |
| Covell v. Heyman, 111 U. S. 176..... | 8 |
| Formulabs, Inc. v. Hartley Pen Co., 275 F. 2d 52, cert. den. 363 U. S. 830..... | 2, 7 |
| Formulabs, Incorporated v. Hartley Pen Company, 306 F. 2d 148 | 3 |
| Freeman v. Howe, 24 How. 450..... | 8 |
| Grasselli Chemical Co. v. National Aniline & Chem. Co., 282 Fed. 379 | 12 |
| Hurn v. Oursler, 289 U. S. 238..... | 8 |
| Johnson Steel Street-Fail Co. v. North Branch Steel Co., 48 Fed. 191..... | 13 |
| Krippendorf v. Hyde, 110 U. S. 276..... | 8, 9, 10, 11, 12 |
| Sandlin v. Johnson, 141 F. 2d 660..... | 15 |
| Smith v. Dravo Corp., 203 F. 2d 369..... | 15 |
| Supreme Tribe of Ben-Hur v. Cauble, 255 U. S. 356..... | 8 |
| Talon, Inc. v. Union Slide Fasteners, Inc., 249 F. 2d 308..... | 2 |
| Tyler, In re, 149 U. S. 164..... | 8 |
| Willson v. Superior Court, 66 Cal. App. 275, 225 Pac. 881.... | 12 |

RULES

| | |
|---|------|
| Federal Rules of Civil Procedure, Rule 24(a)(3) | 2, 7 |
| Federal Rules of Civil Procedure, Rule 54(b) | 2, 4 |
| Federal Rules of Civil Procedure, Rule 82..... | 7 |

STATUTES

| | |
|---|---|
| United States Code, Title 28, Sec. 1291..... | 2 |
| United States Code, Title 28, Sec. 1292(1)..... | 2 |
| United States Court, Title 28, Sec. 1332..... | 1 |

TEXTBOOK

| | |
|--|---|
| Barron & Holtzoff, Federal Practice and Procedure, Sec. 23.... | 8 |
|--|---|

No. 18180

IN THE

United States Court of Appeals

FOR THE NINTH CIRCUIT

FORMULABS, INCORPORATED, a corporation, CLARENCE SCHREUR and GORDON S. LACY, individuals doing business as PACIFIC RESEARCH LABORATORY, a co-partnership,

Appellants,

vs.

HARTLEY PEN COMPANY, a corporation, doing business as THE HARTLEY Co., and E. I. DU PONT DE NEMOURS & COMPANY, a corporation,

Appellees.

**Answering Brief of Appellee E. I. du Pont
de Nemours & Company.**

Statement Showing Jurisdiction.

Jurisdiction of the main action commenced by Hartley Pen Company (herein called "Hartley") against E. I. du Pont de Nemours & Company (herein called "du Pont") for alleged breach of warranty is founded upon diversity of citizenship and an amount in controversy which exceeds the sum of \$10,000.00, exclusive of interest and costs. 28 U. S. C. §1332. Jurisdiction of the ancillary action commenced by

Formulabs, Incorporated, Clarence Schreur and Gordon S. Lacy, intervenors for the sole purpose of protecting their proprietary rights in certain secret ballpen ink formulae which were subject to the control or disposition of the district court and threatened at the time of intervention by the possibility that an order of that court requiring publication of those secrets without limitation might be made, is founded upon Rule 24(a)(3) of the Federal Rules of Civil Procedure and the decision of this court in *Formulabs, Inc. v. Hartley Pen Co.*, 275 F. 2d 52, cert. denied 363 U. S. 830. Hartley and the intervenors are, for diversity purposes, citizens of the State of California; du Pont is a citizen of the State of Delaware.

Intervenors appeal from two interlocutory orders of the district court (one dismissing their complaint in intervention and the other refusing the injunction sought by them against Hartley)¹ and from a final decision of the district court entered pursuant to Rule 54(b) of the Federal Rules of Civil Procedure dismissing their complaint in intervention for lack of jurisdiction over the subject matter as to all claims sought to be asserted by intervenors against Hartley arising out of contractual rights and obligations *inter sese*.

Jurisdiction of this court to review the interlocutory orders and the order for final judgment is founded upon 28 U. S. C. §1292(1) and 28 U. S. C. §1291, respectively.

¹The two interlocutory orders are necessarily entwined, denial of injunctive relief being implicit in dismissal of the complaint in intervention upon which the motion for that relief was predicated. See *Talon, Inc. v. Union Slide Fasteners, Inc.*, 249 F. 2d 308 (9th Cir. 1957).

Statement of Proceedings Following Remand.*

By its July 11, 1962 decision in *Formulabs, Incorporated v. Hartley Pen Company*, 306 F. 2d 148, this court remanded Cause No. 17741 to the district court “with the suggestion and request that the District Court expeditiously rule upon Formulabs’ motion for preliminary injunction and du Pont’s and Hartley’s motion to dismiss the complaint in intervention.” This the district court did on July 26, denying intervenors’ motion for a preliminary injunction [Clk. Tr. ** 54-59] and granting the motion of du Pont and Hartley to dismiss the complaint in intervention.

As evidenced by the interlocutory findings of fact and conclusions of law, the ruling of the district court refusing the injunction was based upon three independent grounds: first, that the district court lacked subject matter jurisdiction to litigate the contractual rights and obligations of Hartley and intervenors *inter sese* [Clk. Tr. 58, par. 4]; second, that on the showing of relevancy and necessity made by du Pont resulting in the district court’s order of limited disclosure made January 10 and filed January 11, 1962, considerations of procedural due process (*viz.*, in du Pont’s being enabled properly to prepare its defense) outweighed the possibility of any adverse effect upon the intervenors’ proprietary rights [Clk. Tr. 58, par. 5]; and third, that, under the conditions of safeguard incorporated in

*A complete statement of the proceedings prior to July 11, 1962, the date of the remand, is contained in du Pont’s brief in opposition to Hartley’s petition for prerogative writs in Cause No. 17799.

**“Clk. Tr.” and “Supp. Clk. Tr.” are used herein to designate, respectively, the Transcript of Record and the Supplemental Transcript of Record in Cause No. 18180.

the order of limited disclosure, no irreparable injury would be done intervenors as no general publication of the ballpen ink secrets was ordered to be made. [Clk. Tr. 58, par. 6.] By its order dismissing the complaint in intervention, the district court granted leave to intervenors to file an amended complaint in intervention joining Hartley

“in opposing all efforts to compel disclosure of any secret formula or secret process or other trade secret in which intervenors may have or claim a property right or other legally cognizable interest, so that intervenors may, if so advised, participate in all future hearings and proceedings which may be had in this action concerned with any disclosure of any such secret formula or secret process or other trade secret.” [Clk. Tr. 63.]

Intervenors thereupon moved the district court for an order for final judgment pursuant to Rule 54(b) of the Federal Rules of Civil Procedure seeking a definitive determination facilitating appeal and review by this court of the single ground that the district court lacked subject matter jurisdiction to determine the contractual rights and obligations between Hartley and the intervenors. [Clk. Tr. 44-48.] That motion was granted and on July 31 an order for final judgment made dismissing the complaint in intervention for lack of jurisdiction over the subject matter as to all claims

“asserted, or sought to be asserted, by intervenors as against [Hartley] in this action, arising out of any alleged contractual rights or obligations

of [Hartley] and intervenors *inter sese*, or otherwise arising under State law, without leave to intervenors to file an amended complaint in intervention asserting any such claims, upon the ground that the requisite diversity of citizenship does not exist and no such claims arise or can arise under the Constitution or laws or treaties of the United States.” [Clk. Tr. 70.]

Agreeably with Hartley’s motion of August 3 [Supp. Clk. Tr. 1-8], the order for final judgment was amended on August 6 so that intervenors would have leave to file an amended complaint in intervention in line with the July 26 dismissal order as above quoted. [Supp. Clk. Tr. 72.] Thereafter and pursuant to stipulation of the parties, the order for final judgment was further modified on August 10 to enlarge the time within which intervenors may, “if so advised,” serve and file an amended complaint in intervention until twenty days after the return to the district court of the mandate of this court in Cause No. 17741. [Clk. Tr. 75-76.]

Summary of Argument.

I.

The district court does not have subject matter jurisdiction over the separate and independent controversy framed by the complaint in intervention. Its dismissal by the district court was, therefore, a necessary and proper result.

II.

Assuming arguendo that jurisdiction of the district court extends to determination of the separate and independent controversy framed by the complaint in intervention, the district court did not abuse its discretion in refusing to enjoin disclosure by Hartley.

A. *The presentation of the truth is a paramount consideration to protection of a proprietary right.*

B. *Under the conditions of safeguard incorporated in the order of limited disclosure, no general publication of the secrets will be made and no irreparable injury done to intervenors.*

ARGUMENT.

I.

The District Court Does Not Have Subject Matter Jurisdiction Over the Separate and Independent Controversy Framed by the Complaint in Intervention. Its Dismissal by the District Court Was, Therefore, a Necessary and Proper Result.

By their complaint in intervention, intervenors sought to litigate in the federal forum their rights and the correlative duties of Hartley under a licensing agreement made between them and Hartley. Had that complaint in intervention initiated an original action in the district court, no subject matter jurisdiction would have obtained because the requisite diversity of citizenship between the adverse parties does not exist and no federal question is thereby presented.²

Absent any independent jurisdictional basis, whether the district court has jurisdiction to entertain the claim framed by the complaint in intervention necessarily depends upon the applicability of the doctrine of ancillary jurisdiction. That doctrine has evolved to mitigate the jurisdictional impediments to increasing the size of a federal lawsuit by construing "case" or "controversy"

²Intervenors contend that an independent jurisdictional basis for the determination of their claim derives from Rule 24(a)(3) of the Federal Rules of Civil Procedure and the decision of this court in *Formulabs, Inc. v. Hartley Pen Co.*, 275 F. 2d 52, cert. denied 363 U. S. 830. That contention is based upon a fundamental misconception both of the scope and purport of the federal rules and of the holding of this court in the first *Formulabs* decision. Rule 82 expressly provides that: "These rules shall not be construed to extend or limit the jurisdiction of the United States district courts. . . ." Fed. R. Civ. P. 82. The sole issue presented in the first *Formulabs* decision—whether the district court erred in denying Formulabs' motion to intervene—was succinctly resolved by this court as follows: "We hold that under the plain language of Rule 24(a)(3) Formulabs had a right to intervene in the main action, and that the district court erred in denying its application." (275 F. 2d 52 at 57.)

in its constitutional context as extending judicial power to determine matters raised by an action properly before the district court of which it could not take cognizance if independently presented. See Barron & Holtzoff, Federal Practice and Procedure §23. Its historical evolution commenced with cases in which the federal court acquired control of a *res* to which an intervenor laid claim. *Freeman v. Howe*, 24 How. 450; *Krippendorf v. Hyde*, 110 U. S. 276. Because federal control, under such circumstances, is exclusive and state process cannot interfere, see *In re Tyler*, 149 U. S. 164, *Covell v. Heyman*, 111 U. S. 176; the intervening claimant to the *res* would be relegated to pursuit of the property after disposition by federal court order were he, because of his citizenship, denied access to the federal forum. To provide an immediate and adequate remedy to the claimant irrespective of his citizenship, the claim was considered capable of adjudication as ancillary to the main action. The concept has since been broadened to effectuate and protect federal judgments, see, *e.g.*, *Supreme Tribe of Ben-Hur v. Cauble*, 255 U. S. 356; and, under the rubric of “pendent jurisdiction”, to permit joinder of related multiple claims only one of which raises a federal question, see *Hurn v. Oursler*, 289 U. S. 238. Whatever may be the limits of the doctrine need not here concern us as intervenors rely exclusively on the concept embodied in the custody or control cases exemplified by *Krippendorf v. Hyde*, *supra*, in asserting that the district court has the power to adjudicate the contractual rights and obligations between them and Hartley under a licensing agreement to which du Pont is not a party and in which it has no interest. That assertion assumes an analogy between *Krippendorf* and the instant action which does not exist.

Krippendorf was a diversity action commenced by Hyde and others in the federal court for the purchase price of certain merchandise allegedly sold to defendants. A writ of attachment levied on goods in the possession of Krippendorf and of which he claimed sole ownership brought the *res* within the court's exclusive control. Krippendorf thereupon filed in the federal court a bill in equity between citizens of the same State seeking to perfect his title to the *res* and to restrain the marshal from disposing of it. From a decree dismissing his bill on demurrer sustained for lack of jurisdiction, Krippendorf appealed. The Supreme Court reversed, holding the bill to be ancillary and saying at 110 U. S. 281-82:

“For if we affirm . . . the exclusive right of the [trial court] in such a case to maintain the custody of property seized and held under its process by its officers, and thus to take from owners, wrongfully deprived of possession, the ordinary means of redress by suits for restitution in State courts, where any one may sue, without regard to citizenship, it is but common justice to furnish them with an equal and adequate remedy in the court itself which maintains control of the property; and, as this may not be done by original suits, on account of the nature of the jurisdiction as limited by differences of citizenship, it can only be accomplished by the exercise of the inherent and equitable powers of the court in auxiliary and dependent proceedings incidental to the cause in which the property is held, so as to give to the claimant, from whose possession it has been taken, the opportunity to assert and enforce his right.”

In the present case, by contrast, neither Hartley nor du Pont disputes intervenors' claimed proprietary rights or asserts any paramount interest (or in the case of du Pont, any interest at all) in the secret ballpen ink formulae. The district court has acquired control over the secrets, not through court process, but by virtue of a licensing agreement willingly made by intervenors prior to the occurrence of the events destined to be litigated between the principal adversaries, Hartley and du Pont. The owners of the secrets have not been in any way deprived of the use or possession of their property and are not threatened with such deprivation under the terms of the discovery order now before this court for review in Cause No. 17799. Furthermore, if any threat to their property should hereafter arise, that threat would stem from the *use* of their property which intervenors themselves sanctioned in electing to license Hartley for royalty. In so doing, intervenors assumed a risk reasonably foreseeable — that disclosure to a third person would be necessary in order to secure procedural due process to that third person in his defense of a claim for supposed injury made by their licensee. No parallel consideration inheres in *Krippendorf*. There an innocent third person found himself deprived of the use and possession of his property as a result of court process issued in aid of an action between two parties, *neither of whom bore any relation to him*. Unlike intervenors, Krippendorf had not voluntarily surrendered any part of his bundle of rights in the property attached. The ancillary or provisional remedy of attachment was misdirected against him, as he desired and as the court ultimately permitted him to show. Not so here.

Here there are no conflicting claims to ownership of the secrets and no question but that Hartley's claim against du Pont arises out of its use under license of those secrets. It is no fortuitous circumstance that finds intervenors before the court in an effort to suppress the information required by du Pont in order properly to prepare its defense. It is a necessary corollary to their voluntary act of having disclosed the secrets to Hartley under limited conditions of safeguard, viz., the terms of the licensing agreement. Having elected to relinquish a measure of their control over the secrets in order better to secure their commercial exploitation, intervenors cannot now contend they stand in the role of Krippendorf—who was not only deprived of the use and possession of his property by court process issued in aid of an action in which he was neither involved nor remotely interested but who was, in addition, relegated to awaiting disposition of his property by court order before even being permitted to assert his claim.

Here, of course, intervenors have been extended the opportunity to oppose *as owners*, together with Hartley, the efforts of du Pont to establish need for limited disclosure of the secrets in order properly to prepare its defense to the main action. That opportunity they have fully exercised *as owners*.³ Their disappointment in the result cannot affect the scope of power of the district court. Similar considerations of fairness to the intervening claimant in *Krippendorf* not prevailing here, the district court lacked the constitutional power to adjudicate the separate and independent controversy

³As intervenors are frank to admit, "They certainly opposed the defendant's effort to show good cause." [Clk. Tr. 30, lines 10-12.]

framed by the complaint in intervention. Dismissal of the intervenors' complaint was, therefore, a necessary and proper disposition.

II.

Assuming Arguendo That Jurisdiction of the District Court Extends to Determination of the Separate and Independent Controversy Framed by the Complaint in Intervention, the District Court Did Not Abuse Its Discretion in Refusing to Enjoin Disclosure by Hartley.

A. The Presentation of the Truth Is a Paramount Consideration to Protection of a Proprietary Right.

Another striking dissimilarity between *Krippendorf* and the present case stems from du Pont's need to know the secret formulae in order properly to prepare its defense to Hartley's claim. Here, then, we have conflict between the policy fostering ascertainment of the truth and that favoring protection of property interests. Where those two policies collide, the interests of justice demand that property rights be subordinated to the end that a proper determination may be made of the civil rights of litigants; if disclosure of the secrets is indispensable to that result, then disclosure must be made. *Coca-Cola Co. v. Joseph C. Wirthman Drug Co.*, 48 F. 2d 743; *Grasselli Chemical Co. v. National Aniline & Chem. Co.*, 282 Fed. 379; *Willson v. Superior Court*, 66 Cal. App. 275, 225 Pac. 881.

Nor do intervenors, by reason of their ownership of the secrets, stand in any position different from that of their licensee. Had they themselves incorporated du Pont's dye in ballpen ink of their own manufacture with the results allegedly obtained by Hartley and had they thereafter commenced an action against du Pont

for damages, they would necessarily have put at hazard the secrecy of the formulae by which their inks were prepared. Having sought and presumably obtained a commercial advantage by revealing the secrets to Hartley under license, intervenors have not insulated themselves from that hazard. So to hold would be to frustrate the public policy requiring disclosure where necessary in order to enable a defendant to prepare his defense. That the secrets sought to be protected are the property of persons not parties to the action is not a proper consideration affecting the requirement of disclosure. *Johnson Steel Street-Rail Co. v. North Branch Steel Co.*, 48 Fed. 191, 192-93.

Thus, assuming *arguendo* that the district court has the power to determine the separate and independent controversy framed by the complaint in intervention and further that injury to the intervenors' proprietary rights would accompany disclosure under the conditions of safeguard incorporated in the order of limited disclosure, refusal of the injunction sought by intervenors did not constitute error. Indeed, it was the only possible solution after the district court had once assessed the showing of relevancy and necessity made by du Pont in favor of, and the opposition made by both Hartley and intervenors against, disclosure of the secrets and had resolved that issue in favor of du Pont. Issuance of the injunction against disclosure would have imposed upon Hartley the obligation to dance to two discordant tunes simultaneously. Even so agile a litigant would find compliance with contrary judicial directives — one directing and the other enjoining disclosure — an impossible demand. The district court's disposition of intervenors' motion for injunctive relief was not only a proper but a necessary result.

B. Under the Conditions of Safeguard Incorporated in the Order of Limited Disclosure, No General Publication of the Secrets Will Be Made and No Irreparable Injury Done to Intervenors.

Further, under the conditions of safeguard incorporated in the order of limited disclosure made January 10 and filed January 11, 1962, no irreparable injury—a necessary condition precedent to the grant of injunctive relief—can conceivably be done intervenors. That order specifically provides:

1. The discovery papers revealing the secret formulae and processing techniques shall be filed with the clerk of the district court under seal to be opened only by order of the court;
2. Copies of such discovery papers shall be served personally upon du Pont's counsel and access thereto shall be restricted to two of their number and to designated experts not exceeding three in number;
3. Du Pont's agents to whom access to such discovery papers is extended are permanently enjoined from disclosing any facts reasonably calculated to lead to the revelation of the secrets except to the extent required during trial under such protective measures as may be adopted by the court to prevent public or undue disclosure.

How compliance on the part of Hartley with that order will destroy the value of intervenors' property is incomprehensible, their assertion that disclosure to du Pont's experts will constitute a total destruction of their proprietary rights by *general publication* to the contrary notwithstanding. That Hartley is better able to withhold disclosure of information revealed to it by inter-

venors in confidence than will be du Pont's agents subject to the coercive power of the district court is a wholly unwarranted if not utterly ridiculous conclusion on intervenors' part. Whatever proprietary rights may attend a trade secret cannot be prejudiced by revelation of that information to a person who has no interest in commercial exploitation of the secret and who is permanently enjoined from either using or revealing it. The touchstone of a trade secret's value is the advantage obtained over *competitors* who do not know or use the secret. *Smith v. Dravo Corp.*, 203 F. 2d 369, 373 (7th Cir. 1953); *Sandlin v. Johnson*, 141 F. 2d 660, 661 (8th Cir. 1944). No issue can seriously be tendered that du Pont will misuse the information disclosed pursuant to the order, either by a publication in contempt of the provisions of that very order or by the competitive manufacture of ballpen ink.

It is true that the order of limited disclosure may portend general publication of the secrets assuming that future proceedings before the district court result in permission to use at trial to a jury the information revealed. Whatever future action may be taken by the district court in that regard cannot, however, be now predicted. That general publication of the secrets will follow their disclosure under the safeguards provided is apprehension on the part of the intervenors, not fact. Intervenors are assured, under the terms of the orders of which they here complain, participation and the opportunity to be heard in all such future proceedings concerned with disclosure in any manner other than that now ordered to be made. No further protection can reasonably be afforded them without serious prejudice to the litigants in the main action and frustration of the judicial process.

Conclusion.

It is, therefore, respectfully submitted that, for the reasons hereinabove recited and those mentioned in the motion and opposition papers filed by du Pont in Cause Nos. 17741 and 17799:

1. The appeal in Cause No. 17741 be dismissed as frivolous or moot;
2. The petition of Hartley for prerogative writs in Cause No. 17799 be denied;
3. The judgment of the district court dismissing the complaint in intervention and the interlocutory orders refusing the injunction sought by intervenors in this Cause No. 18180 be affirmed; and,
4. The order of this court made February 1, 1962 staying the district court's order of limited disclosure be dissolved.

LAWLER, FELIX & HALL,
ROBERT HENIGSON,
*Attorneys for Appellee E. I. du Pont
de Nemours & Co.*

Certificate.

I certify that, in connection with the preparation of this brief, I have examined Rules 18 and 19 of the United States Court of Appeals for the Ninth Circuit, and that, in my opinion, the foregoing brief is in full compliance with those rules.

ROBERT HENIGSON

No. 18181 ✓

**In the United States Court of Appeals
for the Ninth Circuit**

NATIONAL LABOR RELATIONS BOARD, PETITIONER

v.

**WESTERN STATES REGIONAL COUNCIL No. 3, INTERNA-
TIONAL WOODWORKERS OF AMERICA, AFL-CIO AND
INTERNATIONAL WOODWORKERS OF AMERICA, LOCAL
3-101, AFL-CIO, RESPONDENTS**

**ON PETITION FOR ENFORCEMENT OF AN ORDER OF THE
NATIONAL LABOR RELATIONS BOARD**

BRIEF FOR THE NATIONAL LABOR RELATIONS BOARD

STUART ROTHMAN,

General Counsel,

DOMINICK L. MANOLI,

Associate General Counsel,

MARCEL MALLET-PREVOST,

Assistant General Counsel,

SOLOMON I. HIRSH,

IRA M. LECHNER,

Attorneys,

National Labor Relations Board.

FILED
OCT 12 1953
FRANK H. SCHMID, CLERK



INDEX

| | Page |
|---|------|
| Jurisdiction----- | 1 |
| Statement of the case----- | 2 |
| I. The Board's findings of fact----- | 2 |
| A. Background----- | 3 |
| B. The strike at Eclipse----- | 4 |
| C. Picketing at Bayside----- | 5 |
| D. Bayside capitulates to the boycott----- | 6 |
| II. The Board's conclusions and order----- | 7 |
| Argument----- | 8 |
| I. Substantial evidence supports the Board's finding that respondents violated Section 8(b) (4) (i) and (ii) (B) of the Act by inducing and encouraging employees of Bayside and Priest to cease perform- ing services for their respective employers and by threatening, coercing, and restraining Bayside and Priest, all with an object of forcing or requiring Bayside and Priest to cease doing business with Eclipse----- | 8 |
| A. Introduction----- | 8 |
| B. The Board properly concluded that Bay- side was not an ally of Eclipse and that it is protected by the secondary boycott pro- visions of the Act----- | 11 |
| C. The Board properly held the Regional Coun- cil jointly liable with Local 3-101 for the violations of Section 8(b) (4)----- | 16 |
| Conclusion----- | 21 |
| Appendix A----- | 23 |
| Appendix B----- | 26 |

AUTHORITIES CITED

| | |
|---|----------------|
| Cases: | |
| <i>J. I. Case Co. v. N.L.R.B.</i> , 253 F. 2d 149 (C.A. 7)----- | 8 |
| <i>Douds v. Metropolitan Federation of Architects</i> , 75 F. Supp. 672 (S.D. N.Y.)----- | 12, 13, 14, 15 |
| <i>Drivers and Chauffeurs Local Union No. 816 v.</i> <i>N.L.R.B.</i> , 292 F. 2d 329 (C.A. 2), certiorari denied, 368 U.S. 953----- | 13 |

Cases—Continued

| | Page- |
|---|--------|
| <i>Great Western Broadcasting Corp. v. N.L.R.B.</i> , — F. 2d — (C.A. 9), 51 LRRM 2480----- | 10 |
| <i>International Brotherhood of Electrical Workers v. N.L.R.B.</i> : | |
| 181 F. 2d 34 (C.A. 2)----- | 9 |
| 341 U.S. 694----- | 10 |
| <i>International Union of Electrical Workers v. N.L.R.B.</i> , 273 F. 2d 243 (C.A. 3)----- | 8 |
| <i>International Woodworkers of America, AFL-CIO v. N.L.R.B.</i> , 262 F. 2d 233 (C.A.D.C.)----- | 8 |
| <i>Joliet Contractors Ass'n v. N.L.R.B.</i> , 202 F. 2d 606 (C.A. 7), certiorari denied, 346 U.S. 824----- | 10 |
| <i>Lewis v. Benedict Coal Corp.</i> , 259 F. 2d 346 (C.A. 6)--- | 19 |
| <i>Local 294, Teamsters v. N.L.R.B.</i> , 298 F. 2d 105 (C.A. 2)----- | 9 |
| <i>Local 761, International Union of Electrical Workers v. N.L.R.B.</i> , 366 U.S. 667----- | 9 |
| <i>Local 1976, Carpenters Union v. N.L.R.B.</i> , 357 U.S. 93- | 10, 21 |
| <i>McLeod v. U.A.W., Local 365</i> , 200 F. Supp. 778 (E.D. N.Y.), affirmed 299 F. 2d 654 (C.A. 2)----- | 13, 15 |
| <i>N.L.R.B. v. Acme Mattress Co.</i> , 192 F. 2d 524 (C.A. 7)- | 19 |
| <i>N.L.R.B. v. Amalgamated Lithographers of America, et al.</i> , 309 F. 2d 31 (C.A. 9)----- | 12 |
| <i>N.L.R.B. v. Associated Musicians</i> , 226 F. 2d 900 (C.A. 2), certiorari denied, 351 U.S. 962----- | 10 |
| <i>N.L.R.B. v. Business Machine and Office Appliance Mechanics Conference Board</i> , 228 F. 2d 553 (C.A. certiorari denied, 351 U.S. 962----- | 12, 14 |
| <i>N.L.R.B. v. Cement Masons, Local 555</i> , 225 F. 2d 168 (C.A. 9)----- | 20 |
| <i>N.L.R.B. v. Chauffeurs, Teamsters, Warehousemen & Helpers Local Union No. 135</i> , 212 F. 2d 216 (C.A. 7)- | 8, 13 |
| <i>N.L.R.B. v. Crompton-Highland Mills, Inc.</i> , 337 U.S. 217----- | 21 |
| <i>N.L.R.B. v. Dallas General Drivers, Local Union 745</i> , 264 F. 2d 642 (C.A. 5), certiorari denied, 361 U.S. 814----- | 13 |
| <i>N.L.R.B. v. Denver Building & Construction Trades Council</i> , 341 U.S. 675----- | 13 |
| <i>N.L.R.B. v. Eclipse Lumber Co.</i> , 199 F. 2d 684 (C.A. 9)----- | 8 |

Cases—Continued

| | Page |
|--|------------|
| <i>N.L.R.B. v. General Motors Corp.</i> , 179 F. 2d 221 (C.A. 2) ----- | 21 |
| <i>N.L.R.B. v. Highway Truckdrivers and Helpers, Local 107</i> , 300 F. 2d 317 (C.A. 3)----- | 9, 10, 11 |
| <i>N.L.R.B. v. International Rod Carriers, Local No. 1140</i> , 285 F. 2d 397 (C.A. 8), certiorari denied, 366 U.S. 903----- | 9, 10, 11 |
| <i>N.L.R.B. v. Laundry Linen Supply</i> , 262 F. 2d 617 (C.A. 9)----- | 10 |
| <i>N.L.R.B. v. Local 74, Carpenters Union</i> , 181 F. 2d 126 (C.A. 6), affirmed 341 U.S. 707----- | 21 |
| <i>N.L.R.B. v. Local 810 Teamsters</i> , 299 F. 2d 636 (C.A. 2)----- | 13, 14, 15 |
| <i>N.L.R.B. v. Local 926, International Union of Operating Engineers</i> , 267 F. 2d 418 (C.A. 5)----- | 21 |
| <i>N.L.R.B. v. McGraw & Co.</i> , 206 F. 2d 635 (C.A. 6)----- | 21 |
| <i>N.L.R.B. v. Pennsylvania Greyhound Lines</i> , 303 U.S. 261----- | 21 |
| <i>N.L.R.B. v. Plumbers Union of Nassau County</i> , 299 F. 2d 497 (C.A. 2)----- | 10, 11, 21 |
| <i>N.L.R.B. v. United Brotherhood of Carpenters & Joiners</i> , 184 F. 2d 60 (C.A. 10), certiorari denied, 341 U.S. 947----- | 21 |
| <i>Retail Fruit & Vegetable Clerks v. N.L.R.B.</i> , 249 F. 2d 591 (C.A. 9)----- | 13, 19 |
| <i>Superior Derrick Corp. v. N.L.R.B.</i> , 273 F. 2d 891 (C.A. 5), certiorari denied, 364 U.S. 816----- | 10 |
| <i>United Mine Workers v. Patton</i> , 211 F. 2d 742 (C.A. 4)----- | 19 |
| <i>United Steelworkers of America v. N.L.R.B.</i> , 289 F. 2d 591 (C.A. 2)----- | 13 |
| Statutes: | |
| National Labor Relations Act, as amended (61 Stat. 136, 73 Stat. 519, 29 U.S.C. 151, et seq.)----- | 1 |
| Section 8(b) (4) (i) (B)----- | 2, 8 |
| Section 8(b) (4) (ii) (B)----- | 2, 8 |
| Section 10(e)----- | 1 |

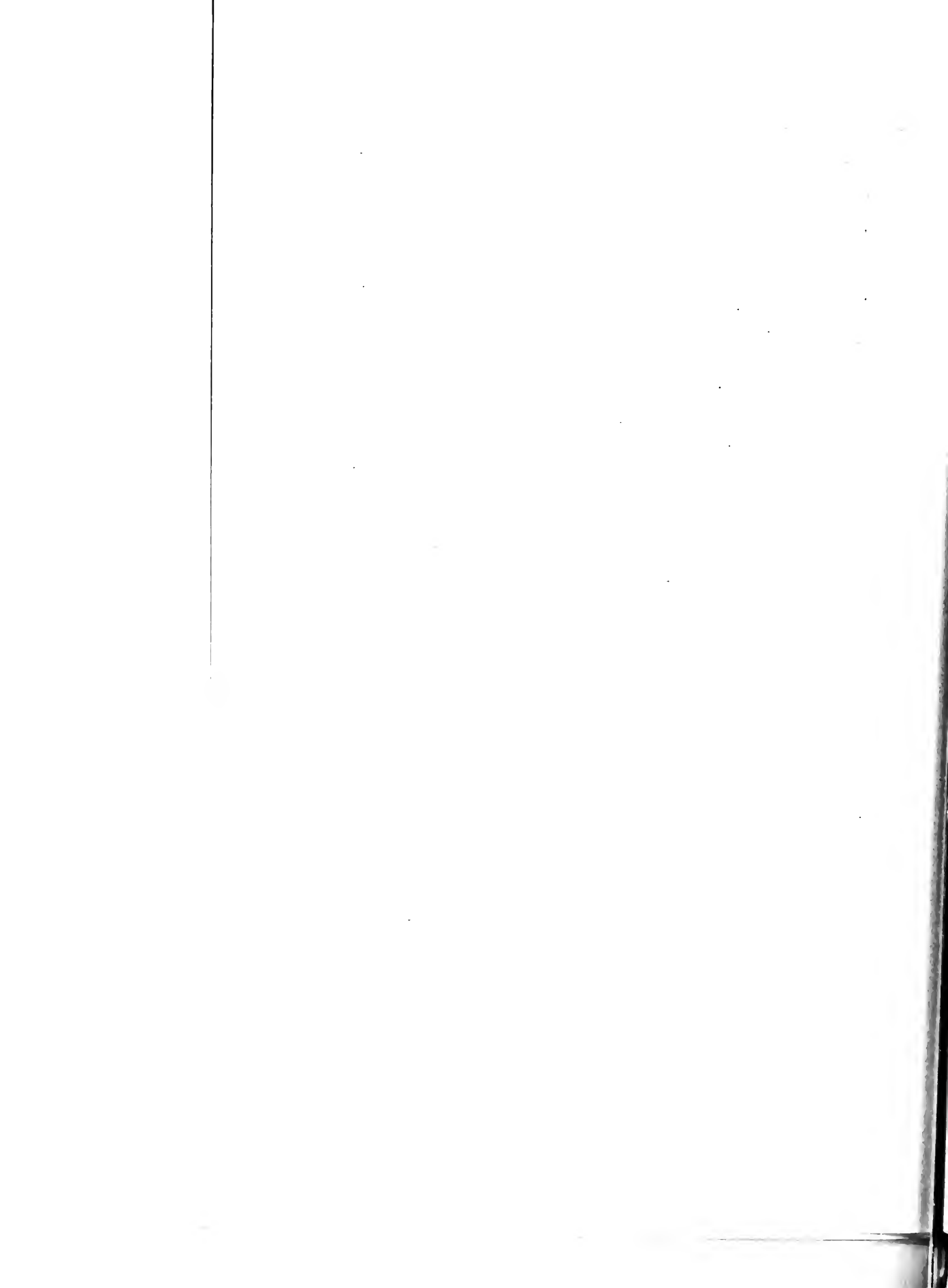

**In the United States Court of Appeals
for the Ninth Circuit**

No. 18181

NATIONAL LABOR RELATIONS BOARD, PETITIONER

v.

WESTERN STATES REGIONAL COUNCIL NO. 3, INTERNATIONAL WOODWORKERS OF AMERICA, AFL-CIO AND INTERNATIONAL WOODWORKERS OF AMERICA, LOCAL 3-101, AFL-CIO, RESPONDENTS

*ON PETITION FOR ENFORCEMENT OF AN ORDER OF THE
NATIONAL LABOR RELATIONS BOARD*

BRIEF FOR THE NATIONAL LABOR RELATIONS BOARD

JURISDICTION

This case is before the Court upon the petition of the National Labor Relations Board, pursuant to Section 10(e) of the National Labor Relations Act, as amended (61 Stat. 136, 73 Stat. 519, 29 U.S.C. 151, *et seq.*),¹ for enforcement of its order, issued May 25, 1962, against Western States Regional Council No. 3 International Woodworkers of America, AFL-CIO (hereinafter referred to as "the Regional Council") and International Woodworkers of America, Local 3-

¹The pertinent provisions of the Act are set forth, *infra*, pp. 23-25.

101, AFL-CIO (hereinafter referred to as “the Union” or “Local 3-101”), respondents herein. The Board’s Decision and Order (R. 29-36)² are reported at 137 NLRB No. 31. This Court has jurisdiction of the proceedings, the unfair labor practices having occurred during a strike by Local 3-101 against the Eclipse Logging Company (“Eclipse”) in Everett, Washington, within this judicial circuit. No jurisdictional issue is presented (R. 22).³

STATEMENT OF THE CASE

I. The Board’s findings of fact

The Board found that respondents violated Section 8(b)(4)(i) and (ii)(B) of the Act by inducing and encouraging employees of Bayside Logging Company (“Bayside”) and Priest Logging, Inc. (“Priest”) to

² References designated “R” are to Volume I of the record as reproduced pursuant to Rule 10 of this Court. References designated “Tr” are to the reporter’s transcript of testimony as reproduced in Volume II of the record. References designated “G.C.X.” or “RX” are to exhibits of the General Counsel and respondent, respectively. Whenever in a series of references a semicolon appears, those preceding the semicolon are to the Board’s findings; those following are to the supporting evidence.

³ Eclipse annually ships lumber outside the State of Washington valued in excess of \$50,000 (R. 22; G.C.X. 1-g, para. IV, 1-i, para. IV, 1-k, para. I).

Priest Logging, Inc., and Bayside Log Dump Co., the two other employers involved in this case, are Washington corporations each annually receiving income in excess of \$50,000 for performing services for business enterprises that ship products to points outside the State of Washington valued in excess of \$50,000 (R. 22; G.C.X. 1-g, para. II, III, 1-i, para. II, III, 1-k, para. I).

refuse in the course of their employment to perform services, and by threatening, coercing and restraining Bayside and Priest, all with an object of forcing or requiring Bayside and Priest to cease doing business with Eclipse. The evidence upon which the Board based its findings is summarized below.

A. Background

Eclipse operates a sawmill in Everett, Washington, where it is engaged in the business of manufacturing logs into lumber (R. 22, 31; Tr. 245). Its employees are represented by Local 3-101 (Tr. 39, 291). Priest is a contract logger engaged in the felling and transportation of timber (R. 22; Tr. 197). In October 1958 Eclipse contracted with Priest to log and deliver timber from lands owned by Eclipse to the sawmill at Everett (R. 22; Tr. 198, 213-215). Under the contract Priest delivered the logs by truck to the sawmill where they were either dumped in the water or placed on land in piles, termed "cold decking" (R. 22; Tr. 204, 212-215). Eclipse's employees unloaded the trucks and handled the grouping of the logs whether they were dumped in the water by the sawmill or "cold decked" (R. 22-23; Tr. 216-219).

Pursuant to the collective bargaining agreement then existing between Eclipse and Local 3-101, the Union opened the contract for negotiations on or about March 16, 1961 (Tr. 16-21, 291-296, G.C.X. 2, 4). The opening notice specified four "industry issues" about which the Union wished to negotiate

(G.C.X. 2).⁴ Local 3-101 authorized the Regional Council to represent it in "all negotiations" on the proposed industry terms "and also on all negotiations on any amendments or revisions requested by [Eclipse]" (G.C.X. 2). James Fadling, Regional Administrator, was sent by the Regional Council to participate in the negotiations which began after June 1 (Tr. 21-24, 94). Eclipse agreed to accept the industry terms, but only on condition that the Union agree to Eclipse's proposed modifications of the work assignments of "boom men" (Tr. 48-54, 138-143, G.C.X. 4, 5, 6).⁵ On August 28 Fadling, after consulting the Local 3-101's standing committee, rejected Eclipse's proposal (Tr. 103-106, 306-308).

B. The strike at Eclipse

On August 29 Eclipse's employees went on strike and placed pickets at the entrance to the sawmill (R. 23; Tr. 216, 299, G.C.X. 1-g, para. IX, 1-i, para. IX). Eclipse could not accept any more deliveries from Priest due to the presence of the pickets and the unavailability of Eclipse employees to handle the logs (R. 23; Tr. 205). The contract between Priest and Eclipse provided that Priest could not be reimbursed for cutting and hauling the logs until they were delivered at Eclipse's premises (R. 23; Tr. 203-205,

⁴The Regional Council and employer associations in the lumber industry had agreed to recommend to all the employers four "industry terms" to be adopted by each individual employer when negotiating collective bargaining agreements with the Union (Tr. 21, 40-41).

⁵"Boom men" are employees who raft and handle logs in a log "boom" or dump (Tr. 32).

213-215). In order to obtain reimbursement, Priest prevailed upon Eclipse "to find a place to dump these logs" (R. 23; Tr. 201-202, 215, 244-245). On September 12 Eclipse agreed to modify the terms of the contract and authorized Priest to deliver Eclipse logs at the Bayside Log Dump (R. 23; Tr. 201, 244-245). Bayside is a "public log dump" which accepts "logs from anybody up to our capacity" for the purpose of storing, sorting, and fashioning logs into rafts (R. 22; Tr. 150-151, G.C.X. 9). Eclipse then arranged with Bayside to unload and store the logs which Priest would begin to deliver on September 13 (R. 23; Tr. 160-161, 168-169, 193-194). The expense of storing the logs at Bayside was to be borne by Eclipse (Tr. 245).

C. Picketing at Bayside

On September 13 Priest trucks began delivery of Eclipse logs to Bayside (R. 23; Tr. 160, 204). After a few truckloads had been unloaded, the Union's pickets appeared at the entrance to Bayside carrying picket signs which read, "ON STRIKE ECLIPSE LUMBER COMPANY UNFAIR TO 3-101, I.W.A., AFL-CIO" (R. 23; Tr. 156-158, 161-162, 188-189, 191). Bayside's employees refused to cross the picket line and stopped working (R. 23; Tr. 159, 171, 190). Bayside's log manager, Percy Ames, asked the pickets the reason for the picketing at Bayside (Tr. 157). George Terry, log dump operator at Eclipse, answered, "These are hot logs going in" (Tr. 157). He further identified the "hot logs" as "Eclipse logs, Priest logs" (Tr. 157). In addition to carrying a

picket sign, Terry told the truck drivers who were delivering logs that the Union was "picketing because the Eclipse logs were being hauled into the dump and being dumped into the Bayside Dump" (Tr. 394-395). He asked the truck drivers not to go through the picket line (Tr. 395). Picket Captain Carl Sorenson testified that the picketing at Bayside "came about because the logs, hot logs, were being delivered to another source other than Eclipse. Well, when the strike committee was informed of it we took the action to place the picket line" (Tr. 369).

Other companies continued to deliver logs, unloading their own trucks, and Bayside soon became congested because there were no employees available to handle the dumped logs (R. 23; Tr. 184, 189-192). Due to the congestion of Bayside's storage facilities, Priest trucks stopped delivering Eclipse logs (R. 23; Tr. 204-205).

D. Bayside capitulates to the boycott

On September 19, 1961, John F. Walthew, the Union's attorney, told Bayside's attorney, James P. Hunter, that Local 3-101 had no labor dispute with Bayside "except insofar as the unloading of the trucks was concerned, that we wanted to stop the unloading of the trucks" (Tr. 66). Hunter asked, "What would happen if Bayside simply refused to take any of Eclipse logs?" (Tr. 61, 66, 229). Union Representative Fadling replied that if Bayside would agree not to handle any more Eclipse logs, the picket line would be removed in a half hour (Tr. 61, 230). Walthew and Hunter reached an agreement which

provided that on condition Bayside "will not accept any Eclipse logs hauled by Reid Priest," the picketing at Bayside would cease (Tr. 59, 61, G.C.X. 7). That afternoon Fadling telephoned Hunter and when told of the terms of the agreement, Fadling expressed his approval (Tr. 61, 86). Local 3-101's strike committee ratified the agreement after Fadling explained the method by which it was negotiated (Tr. 87-88, 379-380). At 6 p.m. the pickets were withdrawn and the next morning Bayside's employees returned to work (R. 23; Tr. 158, 182).

II. The Board's conclusions and order

The Board found that, by picketing, respondent Local 3-101 induced and encouraged the employees of Bayside and Priest to cease performing services for their respective employers with an object of forcing or requiring Priest and Bayside to cease doing business with Eclipse in violation of Section 8(b)(4)(i)(B) of the Act. The Board also found that Local 3-101 threatened, coerced and restrained Bayside and Priest with an object of forcing or requiring Priest and Bayside to cease doing business with Eclipse, thereby violating Section 8(b)(4)(ii)(B) of the Act (R. 31). The Board concluded that the Regional Council, by virtue of the role played by Administrator Fadling, was jointly liable with Local 3-101 for the conduct found violative of the Act (R. 31-33). The Board rejected the Trial Examiner's conclusion that Bayside was an ally of Eclipse and therefore not entitled to the protection of Section 8(b)(4); the Board concluding that Bayside was a neutral secondary em-

ployer who did not perform “struck work” in unloading and storing Eclipse logs (R. 30–31).⁶

ARGUMENT

I. Substantial evidence supports the Board’s finding that respondents violated Section 8(b)(4)(i) and (ii)(B) of the Act by inducing and encouraging employees of Bayside and Priest to cease performing services for their respective employers and by threatening, coercing, and restraining Bayside and Priest, all with an object of forcing or requiring Bayside and Priest to cease doing business with Eclipse

A. Introduction

Section 8(b)(4) of the Act, as amended by the Labor-Management Reporting and Disclosure Act of 1959, provides, in relevant part, that it shall be an unfair labor practice for a union or its agents:

(i) to engage in, or to induce or encourage any individual employed by any person engaged in commerce or in an industry affecting commerce to engage in, a strike or a refusal in the course of his employment to use, manufacture, process, transport, or otherwise handle or work on any goods, articles, materials, * * * or perform any services; or (ii) to threaten, coerce, or restrain any person engaged in com-

⁶ In reversing the Trial Examiner, the Board did not overturn his credibility findings, but only the legal conclusions which he drew from the facts. Accordingly, the Trial Examiner’s contrary conclusions are not entitled to any special weight. *N.L.R.B. v. Eclipse Lumber Co.*, 199 F. 2d 684, 686 (C.A. 9); *N.L.R.B. v. Chauffeurs, Teamsters, Warehousemen and Helpers Local Union No. 135*, 212 F. 2d 216, 217 (C.A. 7); *J. I. Case Co. v. N.L.R.B.*, 253 F. 2d 149, 155–156 (C.A. 7); *International Woodworkers of America, AFL-CIO v. N.L.R.B.*, 262 F. 2d 233, 234 (C.A.D.C.); *I.U.E. v. N.L.R.B.*, 273 F 2d 243, 247 (C.A. 3).

merce or in an industry affecting commerce, where in either case an object thereof is:

* * * * *

(B) forcing or requiring any person to cease * * * handling, transporting, or otherwise dealing in the products of any other producer, processor, or manufacturer, or to cease doing business with any other person * * *.

This section renders unlawful, as did the corresponding provisions of Section 8(b)(4)(A) in the 1947 Act, the implication of neutral employers in disputes not their own where an object is to force the cessation of business relations between the neutral employer and any other person. "The impact of the section [is] directed toward what is known as the secondary boycott whose 'sanctions bear, not upon the employer who alone is a party to the dispute, but upon some third party who has no concern in it.' *International Brotherhood of Electrical Workers v. Labor Board*, 181 F. 2d 34, 37." *Local 761, International Union of Electrical Workers v. N.L.R.B.*, 366 U.S. 667, 672. By enacting the 1959 amendments, Congress substantially broadened the scope of the prohibition against conduct aimed at achieving these objectives. Thus, in subparagraph (i), there is now contained a specific prohibition against inducement of an individual employee to stop work. *N.L.R.B. v. Highway Truckdrivers & Helpers, Local No. 107*, 300 F. 2d 317, 319, 322 (C.A. 3); *Local 294, Teamsters v. N.L.R.B.*, 298 F. 2d 105, 107-108 (C.A. 2); *N.L.R.B. v. International Hod Carriers, Local 1140*, 285 F. 2d 397, 402 (C.A. 8), cert. denied 366 U.S. 903. This is

in contrast to the 1947 provision, which only prohibited inducement of "employees" to engage in a "concerted" refusal to perform work. See *Local 1976, Carpenters Union v. N.L.R.B.*, 357 U.S. 93, 98; *Joliet Contractors Ass'n. v. N.L.R.B.*, 202 F. 2d 606, 612 (C.A. 7), cert. denied 346 U.S. 824. In addition, Congress introduced a new provision, contained in subparagraph (ii), making it unlawful for a union to "threaten, coerce, or restrain any person" for the purpose of achieving any of the proscribed secondary objectives. This subparagraph forecloses threats made to neutral employers of labor trouble or other consequences, and prohibits the carrying out of such threats by means of a strike or other economic retaliation. *Great Western Broadcasting Corp. v. N.L.R.B.*, F. 2d (C.A. 9), 51 LRRM 2480; *N.L.R.B. v. Highway Truckdrivers & Helpers, Local No. 107, supra*, at 320-321; *N.L.R.B. v. Plumbers Union of Nassau County*, 299 F. 2d 497, 500 (C.A. 2); *N.L.R.B. v. International Hod Carriers, Local 1140, supra*.

There can be no question, on the facts set forth, *supra*, pp. 5-7, but that by means of solicitation and picketing, the Union induced and encouraged the employees of Bayside to cease performing services in the course of their employment,⁷ and that by such conduct, and the threats thereof, also threatened, re-

⁷ See, e.g., *International Brotherhood of Electrical Workers v. N.L.R.B.*, 341 U.S. 694, 700-704; *N.L.R.B. v. Laundry, Linen Supply*, 262 F. 2d 617, 620 (C.A. 9); *Superior Derrick Corp. v. N.L.R.B.*, 273 F. 2d 891, 896 (C.A. 5), cert. denied 364 U.S. 816; *N.L.R.B. v. Associated Musicians*, 226 F. 2d 900, 904 (C.A. 2), cert. denied 351 U.S. 962.

strained and coerced Bayside and Priest⁸—all with an object of forcing or requiring those employers to cease doing business with Eclipse.⁹ The Union's sole defense to the finding that its above-described conduct violated Section 8(b)(4)(i) and (ii)(B) of the Act is that Bayside, by accepting the Eclipse logs from Priest for storage, allied itself with Eclipse in the primary dispute and thereby made itself vulnerable to picketing by the Union. The Board rejected this contention however, and concluded that on the facts of this case, the Union's picketing of Bayside was unlawful. We show below that the Board's conclusion is amply supported by the record, and is valid.

B. The Board properly concluded that Bayside was not an ally of Eclipse and that it is protected by the secondary boycott provisions of the Act

As shown in the Statement, *supra*, p. 4, the contract between Priest and Eclipse provided that Priest could not be paid for cutting and hauling the Eclipse logs until those logs were delivered to the premises of Eclipse. When the Eclipse employees struck on August 29, Priest was unable to effectuate delivery of the logs because no Eclipse employees were avail-

⁸ See, e.g., *N.L.R.B. v. Highway Truckdrivers & Helpers, Local No. 107*, 300 F. 2d 317 (C.A. 3); *N.L.R.B. v. Plumbers Union of Nassau County*, 299 F. 2d 497, 500 (C.A. 2); *N.L.R.B. v. International Hod Carriers, Local 1140*, 285 F. 2d 397 (C.A. 8), cert. denied 366 U.S. 903.

⁹ In its answer to the complain, Local 3-101 admitted that it engaged in the picketing "for the purpose of informing Bayside employees that the work of unloading the Priest trucks was 'struck work' from Eclipse Mill" (G.C.X. 1-i, para. XI); and that "the purpose of the pickets stationed adjacent to Bayside was to require Bayside and Priest to cease unloading Eclipse logs at Bayside" (G.C.X. 1-i, para. XII).

able to handle them. The direct consequence of this tie-up, therefore, was that Priest would not be paid for its services. Then, as the Trial Examiner found, Priest, "actuated by these financial considerations, * * * prevailed upon Eclipse to arrange with Bayside Log Dump for the storing of Eclipse logs that would be delivered to it by Priest, and Priest would then receive reimbursement. Eclipse agreed to make such arrangements with Bayside and did so. Carrying out this arrangement on September 13, 1961, Priest trucks delivered Eclipse logs to Bayside" (R. 23; Tr. 160-161, 168-169, 201-202, 215, 244-245).

Respondents contend that Bayside, by its knowing acceptance and unloading of Eclipse logs delivered by Priest, performed "struck work"—i.e., services for Eclipse which, but for the strike, normally would have been performed by Eclipse employees. Thus, the argument proceeds, Bayside became an ally of Eclipse and a party to the dispute, unprotected by Section 8(b)(4)(i) and (ii)(B) of the Act. See *N.L.R.B. v. Amalgamated Lithographers of America, et al.*, 309 F. 2d 31, 36-38 (C.A. 9); *N.L.R.B. v. Business Machine and Office Appliance Mechanics Board*, 228 F. 2d 553 (C.A. 2) cert. denied 351 U.S. 962; *Douds v. Metropolitan Federation of Architects*, 75 F. Supp. 672 (S.D. N.Y.).

This argument, however, misconceives the nature of the "struck work" doctrine, which is an exception to the normal principles by which the Act's protection against secondary boycotts is accorded to neutral employers. It is well settled that an employer is not deprived of his neutral status and the accompanying safeguards of Section 8(b)(4) simply because he

performs services for the primary employer. "The business relationship between independent contractors is too well established in the law to be overridden without clear language [in the Act] doing so." *N.L.R.B. v. Denver Building and Construction Trades Council*, 341 U.S. 675, 690.¹⁰ As the cases cited in this and the preceding paragraph recognize, the difference between a secondary employer becoming an unprotected ally of the primary by doing struck work, and one remaining a protected neutral employer even though doing business with the primary, lies in the fact that in the former situation, "the economic effect upon [the striking] employees [is] precisely that which would flow from [the primary employer] hiring strike-breakers to work on its own premises." *Douds v. Metropolitan Federation of Architects, supra*, at 677. The allied employer is "hired [by the primary] to do its everyday business in an effort to preserve its good will and perhaps its profits." *United Steelworkers v. N.L.R.B.*, 289 F. 2d 591, 595 (C.A. 2). Under those circumstances, the secondary employees are, in effect, primary employees, and the striking union has as much right to picket the secondary employer as it has to picket the primary premises. "If

¹⁰ Accord: *Retail Fruit & Vegetable Clerks v. N.L.R.B.*, 249 F. 2d 591, 594-595 (C.A. 9); *N.L.R.B. v. Local 810, Teamsters*, 299 F. 2d 636, 637 (C.A. 2); *Drivers & Chauffeurs Local Union 816 v. N.L.R.B.*, 292 F. 2d 329, 331 (C.A. 2), cert. denied, 368 U.S. 953; *N.L.R.B. v. Dallas General Drivers, etc., Local 745*, 264 F. 2d 642, 647 (C.A. 5), cert. denied, 361 U.S. 814; *N.L.R.B. v. Chauffeurs, Teamsters, Warehousemen & Helpers Local Union No. 135*, 212 F. 2d 216, 217-218 (C.A. 7); *McLeod v. U.A.W., Local 365*, 200 F. Supp. 778, 780-781 (E.D. N.Y.), affd. 299 F. 2d 654 (C.A. 2).

the latter is not amenable to judicial restraint neither is the former.” *Douds v. Metropolitan Federation of Architects, supra*. On the other hand, the fact that a secondary employer does business with the strike-bound primary employer—business other than the performance of services which *supplants* the work that the striking employees would have performed—does not render the secondary an ally of the primary even though it would necessarily tend to diminish the effectiveness of the strike. See, e.g., *N.L.R.B. v. Local 810, Teamsters*, 299 F. 2d 636 (C.A. 2), where the court held that a secondary employer who performed trucking and warehousing services for the primary did not become an ally even when, during the course of the strike, he provided cars and drivers to the primary for the transportation of nonstriking employees across the picket line.

In the case at bar, Bayside’s acceptance of Eclipse logs for storage did not aid Eclipse in “breaking” the strike, for Bayside did not carry on Eclipse’s business in its stead. Cf. *N.L.R.B. v. Business Machine & Office Appliance Mechanics Board*, 228 F. 2d 553, 558 (C.A. 2); *Douds v. Metropolitan Federation of Architects, supra*, at 676–677. Eclipse operates a sawmill while Bayside is a public log dump. The work which Bayside performed was not “struck work” for Bayside did not mill the logs in circumvention of the strike but merely performed the function of a warehouse. Eclipse arranged for the storage of its logs with Bayside purely as a convenience to Priest who could not be reimbursed for his logging services until the logs were delivered. While Bayside did perform

some service for Eclipse, that did not make the former an ally of the latter. Cf. *N.L.R.B. v. Local 810, Teamsters, supra*. The economic effect of Bayside's activity upon the strikers does not parallel Eclipse's hiring of strikebreakers to perform their work.

Moreover, the unloading of Eclipse logs by Bayside did not supplant the work of the striking employees but merely duplicated it. Eclipse's employees normally unloaded Priest's trucks; however, the logs stored at Bayside were destined for later delivery to Eclipse at the cessation of the strike, and the normal unloading work of the striking employees thus remained to be performed. Therefore, Bayside did not perform "work, which but for the strike * * *, would have been done by" Eclipse, for the ally test presupposes that the work done by the secondary suppliants, rather than merely duplicates, the work of the primary. *Douds v. Metropolitan Federation of Architects, supra*, at 677.¹¹

¹¹ Cf. *McLeod v. U.A.W., Local 365*, 200 F. Supp. 778 (E.D. N.Y.), aff'd. 299 F. 2d 654 (C.A. 2). There, the primary's employees normally loaded goods produced by the primary onto trucks for shipment. Before the strike began, certain goods which had been loaded onto trucks by the employees were sent to a warehouse for storage pending completion of financial arrangements with the buyer. During the strike, when the primary sought to remove the goods from the warehouse for shipment by means of an independent trucker, the union picketed the warehouse and induced the warehouse employees not to load the goods on the trucks. The union contended that the loading of the goods by the warehouse employees constitutes struck work, thereby making the warehouse an ally of the primary. The court rejected the contention, noting that the striking employees performed the loading only when the goods leave the primary's plant. The striking employees performed that

Accordingly, the Board properly found that Bayside is not an ally of Eclipse and thus is protected by Section 8(b)(4)(i) and (ii)(B) of the Act.

C. The Board properly held the Regional Council jointly liable with Local 3-101 for the violations of Section 8(b)(4)

When Local 3-101 advised Eclipse of its desire to open their collective bargaining agreement for revision and amendment of the contract relating to certain "industry terms," the Union's notice stated (G.C. X. 2):

* * * This Local Union * * * notifies you that the Western States Regional Council No. 3, International Woodworkers of America, has sole authority to represent it in all negotiation on the proposed amendments and revisions stated above *and also on all negotiations on any amendments or revisions requested by you or your representatives. Any departure from this notice must be in writing to you over the signature of the Western States Regional Council No. 3.*

* * * * *

Any additional revision or amendment which this Local Union desires shall not be a subject

function in connection with the shipment of these goods to the warehouse. Having already loaded them onto trucks once, "there was no further work to be done by respondent as to the machines; consequently, there was no shunting by [the primary] to neutrals of work generally done by respondent" (*id.*, at 781). The facts of the instant case present the converse situation: Bayside's unloading of the trucks would not supplant Eclipse's employees' work task of unloading when the logs stored at Bayside are shipped to Eclipse at the cessation of the strike. Hence, the unloading at Bayside was not "struck work."

of negotiations by the above-mentioned council. The Local Union retains the right and privilege of meeting with you or your representatives on these matters. [Emphasis added.]

Pursuant to this authorization, the Regional Council sent Fadling, its Area Administrator, to serve as its spokesman in the negotiations with Eclipse. On August 28, as a result of these negotiations, Eclipse agreed to accept the industry terms, but only on condition that the Union agree to certain contract modifications relating to "local issues" (G.C. X. 6). Fadling rejected the employer's proposals on the ground that Eclipse had failed to give timely notice of its intention to raise these issues as required by the contract (Tr. 41, 48, 417-418). Neither party would modify its position, and the Eclipse employees went on strike the next day. When Bayside began receiving Eclipse logs on September 13, the Union began picketing Bayside and continued to do so until Bayside agreed not to handle any more Eclipse logs—an agreement which Fadling helped to negotiate.

No one disputes that Fadling's conduct during the picketing of Bayside is attributable to Local 3-101. At issue here is the liability of the Regional Council for his participation in extracting the agreement from Bayside to cease doing business with Eclipse (*supra*, pp. 6-7). The Regional Council contends that Fadling was only authorized to represent it in the negotiation of the industry terms, and that when Eclipse agreed to those terms on August 28, the role of Fadling as

agent of the Regional Council came to an end. Thereafter, respondents claim, Fadling was acting only on behalf of Local 3-101 pursuant to a specific authorization of the Local, and none of his subsequent conduct could be attributed to the Regional Council.

The Board rejected this argument as lacking in merit, and this rejection is entitled to affirmance by the Court. The Regional Council's involvement in the negotiations between Local 3-101 and Eclipse was not limited to settlement of the industry terms. The Local's notice to Eclipse, *supra*, specifically provided that the Regional Council was to represent the Local "on all negotiations on any amendments or revisions requested by [Eclipse] or [its] representatives." The disagreement between the parties on August 28 arose over "amendments or revisions requested by [Eclipse]." By the very terms of this authorization, therefore, it is apparent that Fadling—as the *Regional Council's spokesman at these negotiations*—was acting within the scope of the authority given the Regional Council by the Local to reject these demands and to participate in the resulting strike activities deemed necessary to compel Eclipse to forsake the concessions it was seeking in return for agreement on the industry terms. If the Regional Council had limited Fadling's authority in any way, i.e., if he had been instructed not to act on its behalf in dealing with local issues raised by the employer, the Regional Council was duty-bound to so notify Eclipse of this restriction, for as the Local's authorization stated:

Any departure from this notice must be in writing to [Eclipse] over the signature of the Western States Regional Council No. 3.

Such notice in writing was never given; and in the absence of such notification, the Regional Council is clearly liable for the conduct of its spokesman in dealing with the "amendments or revisions requested by [Eclipse]." See, *Retail Fruit & Vegetable Clerks Union v. N.L.R.B.*, 249 F. 2d 591, 597-598 (C.A. 9); *N.L.R.B. v. Acme Mattress Co., Inc.*, 192 F. 2d 524, 527 (C.A. 7); *United Mine Workers v. Patton*, 211 F. 2d 742, 746 (C.A. 4); *Lewis v. Benedict Coal Corp.*, 259 F. 2d 346, 351-352 (C.A. 6).

Respondents may contend, however, that the Local authorized the Regional Council to represent it only as to the industry terms, and that it was beyond the scope of the Regional Council's authority to become involved in the dispute over the local issues raised by the employer. The short answer to this argument is that the Local's written authorization (G.C.X. 2), copies of which were sent to both Eclipse and the Regional Council, is by its own terms not so limited. Moreover, even if the authorization could be construed in the restricted fashion suggested, that would offer no aid to respondents. For the record shows that Eclipse had not accepted the industry terms when the strike began (Tr. 48, G.C.X. 6). Indeed, the purpose of the strike was to compel Eclipse to accept the industry terms without the Local having to accept the other contract modifications sought by Eclipse in return. Absent any notice to the contrary, no third

party could reasonably believe that Fadling's role as agent of the Regional Council was at an end when, on August 28, Eclipse said, in effect, that if it should ever sign a revised contract, the industry terms sought by the Regional Council would be included. One would expect that the Regional Council, as the Local's bargaining representative, would necessarily be concerned with whether the contract which included those terms would ever become effective. Under these circumstances, if Fadling did not have the actual authority to act on behalf of the Regional Council in the events subsequent to August 28, he certainly had the apparent authority; and as the Board found: "[The Regional Council] never made clear to any of the parties in interest when the authority with which it had cloaked Fadling to act as its agent terminated. Nor did it ever disavow any of Fadling's conduct. Furthermore, Fadling himself never undertook to advise the interested parties that he was not acting for his employing principal, the Respondent Regional Council, at any of the times material here" (R. 33).

Accordingly, Fadling's admitted participation in the secondary boycott was within the apparent scope of his authority as representative of the Regional Council, and the Board could properly hold the Regional Council jointly liable with Local 3-101 for the proscribed secondary activity. *N.L.R.B. v. Cement Masons Local 555*, 225 F. 2d 168, 173 (C.A. 9); *N.L.R.B. v. Acme Mattress Co., Inc.*, *supra*.

CONCLUSION

For the reasons stated, it is respectfully submitted that a decree should issue enforcing the Board's order in full.¹²

STUART ROTHMAN,
General Counsel,
 DOMINICK L. MANOLI,
Associate General Counsel,
 MARCEL MALLET-PREVOST,
Assistant General Counsel,
 SOLOMON I. HIRSH,
 IRA M. LECHNER,
Attorneys,
National Labor Relations Board.

JANUARY 1963.

¹² In their answer to the Board's enforcement petition, respondents asserted that no order should issue because the picketing of Bayside had already ceased, the primary dispute with Eclipse had been settled, and Eclipse has since ceased doing business in Everett, Washington, because its property there was destroyed by fire. It is well settled, however, that none of these circumstances provide a basis for denial of the Board's petition. "[T]ermination of the picketing, the walkout and the particular job itself do not render the Board's order moot." *N.L.R.B. v. Plumbers Union of Nassau County*, 299 F. 2d 497, 501 (C.A. 2). Accord: *Local 1976, Carpenters Union v. N.L.R.B.*, 357 U.S. 93, 97, n. 2; *N.L.R.B. v. Crompton-Highland Mills, Inc.*, 337 U.S. 217, 225, n. 7; *N.L.R.B. v. Pennsylvania Greyhound Lines*, 303 U.S. 261, 271; *N.L.R.B. v. Local 926, I.O.U.E.*, 267 F. 2d 418, 420 (C.A. 5); *N.L.R.B. v. F. H. McGraw & Co.*, 206 F. 2d 635, 641 (C.A. 6); *N.L.R.B. v. United Brotherhood of Carpenters and Joiners*, 184 F. 2d 60, 63 (C.A. 10), cert. denied, 341 U.S. 947; *N.L.R.B. v. Local 74, Carpenters Union*, 181 F. 2d 126, 132-133 (C.A. 6), aff'd 341 U.S. 707; *N.L.R.B. v. General Motors*, 179 F. 2d 221, 222 (C.A. 2)

CERTIFICATE

The undersigned certifies that he has examined the provisions of rules 18 and 19 of this Court, and in his opinion the tendered brief conforms to all requirements.

MARCEL MALLET-PREVOST,
Assistant General Counsel,
National Labor Relations Board.

APPENDIX A

The relevant provisions of the National Labor Relations Act, as amended (61 Stat. 136, 73 Stat. 519, 29 U.S.C., Secs. 151, *et seq.*) are as follows:

* * * * *

SEC. 2. When used in this Act—

* * * * *

(13) In determining whether any person is acting as an “agent” of another person so as to make such other person responsible for his acts, the question of whether the specific acts performed were actually authorized or subsequently ratified shall not be controlling.

* * * * *

SEC. 8(b). It shall be unfair labor practice for a labor organization or its agents—

(4) (i) to engage in, or to induce or encourage any individual employed by any person engaged in commerce or in an industry affecting commerce to engage in, a strike or a refusal in the course of his employment to use, manufacture, process, transport, or otherwise handle or work on any goods, articles, materials, or commodities or to perform any services; or (ii) to threaten, coerce, or restrain any person engaged in commerce or in an industry affecting commerce, where in either case an object thereof is:

* * * * *

(B) forcing or requiring any person to cease using, selling, handling, transporting, or otherwise dealing in the products of any

other producer, processor, or manufacturer, or to cease doing business with any other person, or forcing or requiring any other employer to recognize or bargain with a labor organization as the representative of his employees unless such labor organization has been certified as the representative of such employees under the provisions of section 9: *Provided*, That nothing contained in this clause (B) shall be construed to make unlawful, where not otherwise unlawful, any primary strike or primary picketing;

* * * * *

SEC. 10. (e) The Board shall have power to petition any court of appeals of the United States, * * * within any circuit * * * wherein the unfair labor practice in question occurred or wherein such person resides or transacts business, for the enforcement of such order and for appropriate temporary relief or restraining order, and shall file in the court the record in the proceedings, as provided in section 2112 of title 28, United States Code. Upon the filing of such petition, the court shall cause notice thereof to be served upon such person, and thereupon shall have jurisdiction of the proceeding and of the question determined therein, and shall have power to grant such temporary relief or restraining order as it deems just and proper, and to make and enter a decree enforcing, modifying, and enforcing as so modified, or setting aside in whole or in part the order of the Board. No objection that has not been urged before the Board, its member, agent, or agency, shall be considered by the court, unless the failure or neglect to urge such objec-

tion shall be excused because of extraordinary circumstances. The findings of the Board with respect to questions of fact if supported by substantial evidence on the record considered as a whole shall be conclusive. If either party shall apply to the court for leave to adduce additional evidence and shall show to the satisfaction of the court that such additional evidence is material and that there were reasonable grounds for the failure to adduce such evidence in the hearing before the Board, its member, agent, or agency, the court may order such additional evidence to be taken before the Board, its member, agent, or agency, and to be made apart of the record * * * Upon the filing of the record with it, the jurisdiction of the court shall be exclusive and its judgment and decree shall be final, except that the same shall be subject to review by the * * * Supreme Court of the United States upon writ of certiorari or certification as provided in section 1254 of title 28.

APPENDIX B

INDEX TO REPORTER'S TRANSCRIPT

| Exhibit No. | General Counsel's Exhibits— | | |
|-----------------|-----------------------------|---------|----------------------|
| | Identified | Offered | Received in Evidence |
| 1-a to 1-1..... | 5 | 5 | 5 |
| 2..... | 18 | 18 | 19 |
| 3..... | 26 | 29 | 29 |
| 4..... | 49 | 49 | 50 |
| 5..... | 52 | 52 | 52 |
| 6..... | 54 | 54 | 54 |
| 7..... | 59 | 63 | 63 |
| 8..... | 135 | 135 | 136 |
| 9..... | 153 | 153 | 153 |
| 10..... | 340 | 339 | 340 |

WITNESSES FOR THE GENERAL COUNSEL

| | |
|--|---|
| <p>Fadling, James Edgar :</p> <p style="padding-left: 20px;">Direct 12</p> <p style="padding-left: 20px;">Direct 73</p> <p style="padding-left: 20px;">Cross 88</p> <p style="padding-left: 20px;">Redirect 90</p> <p style="padding-left: 20px;">Recross 92</p> <p style="padding-left: 20px;">Redirect 93</p> <p style="padding-left: 20px;">Examination 94</p> <p>Hunter, James P. :</p> <p style="padding-left: 20px;">Direct 56</p> <p style="padding-left: 20px;">Cross 65</p> <p style="padding-left: 20px;">Redirect 70</p> <p style="padding-left: 20px;">Recross 71</p> <p>Studebaker, Robert I. :</p> <p style="padding-left: 20px;">Direct 96</p> <p style="padding-left: 20px;">Cross 108</p> <p style="padding-left: 20px;">Examination 127</p> <p style="padding-left: 20px;">Cross 129</p> <p style="padding-left: 20px;">Redirect 133</p> <p style="padding-left: 20px;">Examination 136</p> <p style="padding-left: 20px;">Redirect 143</p> <p>Ames, Percy G. :</p> <p style="padding-left: 20px;">Direct 148</p> <p style="padding-left: 20px;">Cross 167</p> <p style="padding-left: 20px;">Redirect 181</p> | <p style="text-align: right;">Ames, Percy G.—Continued</p> <p style="padding-left: 20px;">Recross 182</p> <p style="padding-left: 20px;">Redirect 183</p> <p style="padding-left: 20px;">Recross 185</p> <p style="padding-left: 20px;">Redirect 191</p> <p style="padding-left: 20px;">Recross 193</p> <p style="padding-left: 20px;">Redirect 195</p> <p style="text-align: right;">Priest, Reid G. :</p> <p style="padding-left: 20px;">Direct 197</p> <p style="padding-left: 20px;">Cross 212</p> <p style="text-align: right;">Lee, F. Robert :</p> <p style="padding-left: 20px;">Direct 228</p> <p style="padding-left: 20px;">Cross 231</p> <p style="padding-left: 20px;">Redirect 242</p> <p style="text-align: right;">McCartney, Robert T. :</p> <p style="padding-left: 20px;">Direct 243</p> <p style="padding-left: 20px;">Cross 249</p> <p style="padding-left: 20px;">Examination 285</p> <p style="padding-left: 20px;">Redirect 260</p> <p style="padding-left: 20px;">Recross 261</p> <p style="padding-left: 20px;">Redirect 264</p> <p style="padding-left: 20px;">Recross 266</p> <p style="padding-left: 20px;">Examination 266</p> <p style="padding-left: 20px;">Redirect 423</p> <p style="padding-left: 20px;">Recross 426</p> |
|--|---|

WITNESSES FOR THE RESPONDENTS

| | | | |
|----------------------|-----|-----------------------------|-----|
| Bordsen, Edward S. : | | Sorenson, Carl T.—Continued | |
| Direct ----- | 289 | Cross ----- | 377 |
| Cross ----- | 312 | Terry, George W. : | |
| Redirect ----- | 351 | Direct ----- | 381 |
| Recross ----- | 356 | Cross ----- | 388 |
| Redirect ----- | 357 | Redirect ----- | 395 |
| Sorenson, Carl T. : | | Recross ----- | 396 |
| Direct ----- | 361 | Fadling, James Edgar : | |
| Cross ----- | 368 | Direct ----- | 399 |
| Examination ----- | 373 | Cross ----- | 419 |

